

Subject: RATTLING NOISE FROM LEFT REAR OF VEHICLE	Bulletin No.: 01-009/19
	Last Issued: 02/13/2019

APPLICABLE MODEL(S)/VINS

2019 CX-5 2.5L Turbo vehicles with VINs lower than JM3KE*****514172 (produced before Oct. 27, 2018)
2019 CX-5 2.5L Turbo (Mexico Spec) vehicles with VINs lower than JM3KE*****514172 (produced before Oct. 27, 2018)

DESCRIPTION

Some customers may notice a rattling noise coming from the left rear of the vehicle while driving on bumpy roads. The noise may be caused by interference between the left rear hanger bracket and the hanger rod, due to a lack of clearance.



The shape of the left rear hanger bracket has been changed.

CONSUMER NOTICE: The information and instructions in this bulletin are intended for use by skilled technicians. Mazda technicians utilize the proper tools/equipment and take training to correctly and safely maintain Mazda vehicles. These instructions should not be performed by "do-it-yourselfers." Customers should not assume this bulletin applies to their vehicle or that their vehicle will develop the described concern. To determine if the information applies, customers should contact their nearest authorized Mazda dealership. Mazda North American Operations reserves the right to alter the specifications and contents of this bulletin without obligation or advance notice. All rights reserved. No part of this bulletin may be reproduced in any form or by any means, electronic or mechanical---including photocopying and recording and the use of any kind of information storage and retrieval system ---without permission in writing.

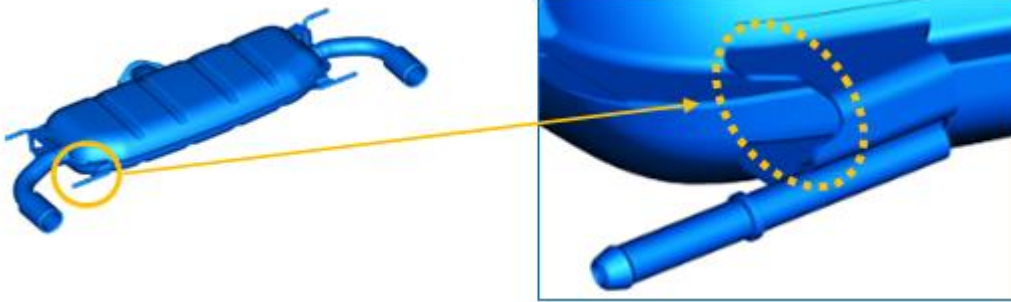

REPAIR PROCEDURE

1. Verify the customer concern.
2. Measure the gap between the left rear hanger bracket and the hanger rod.

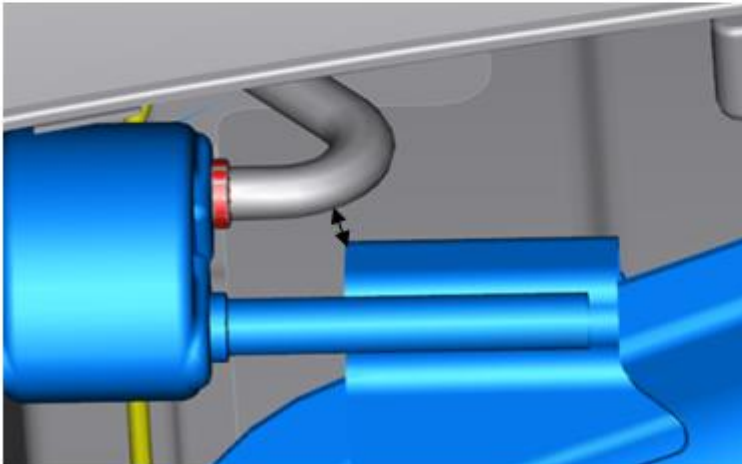

NOTE: Measure the gap at the narrowest point between the hanger bracket and the hanger rod (as shown above).

CONSUMER NOTICE: The information and instructions in this bulletin are intended for use by skilled technicians. Mazda technicians utilize the proper tools/equipment and take training to correctly and safely maintain Mazda vehicles. These instructions should not be performed by "do-it-yourselfers." Customers should not assume this bulletin applies to their vehicle or that their vehicle will develop the described concern. To determine if the information applies, customers should contact their nearest authorized Mazda dealership. Mazda North American Operations reserves the right to alter the specifications and contents of this bulletin without obligation or advance notice. All rights reserved. No part of this bulletin may be reproduced in any form or by any means, electronic or mechanical---including photocopying and recording and the use of any kind of information storage and retrieval system ---without permission in writing.

3. Depending on the measurement, take the corresponding action.

- If the gap is 7mm or more, this service information does not apply. Inspect and repair vehicle according to the instructions on MGSS online.

- If the gap is less than 7mm, replace the main silencer with a modified one according to the instructions on MGSS online (EXHAUST SYSTEM REMOVAL/INSTALLATION [SKYACTIV-G 2.5T]).

NOTE: The insulator or remainder of the exhaust system does not need to be removed to replace the silencer. Replace the silencer by removing the two (2) nuts and separating the three (3) rubber hangers from the main silencer.

4. Confirm the clearance is 7mm or more as indicated in Step 2.

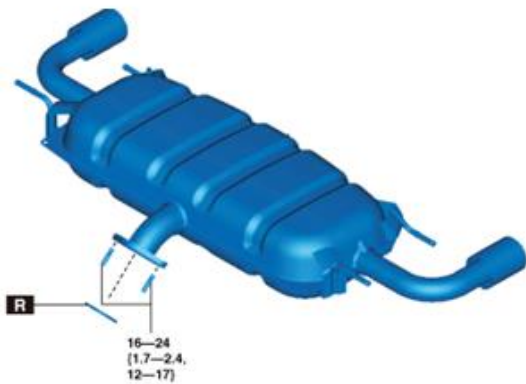

PARTS INFORMATION

Parts Number	Description	Qty.	Notes
PY2B-40-100A	Main Silencer	1	---
PE23-40-305	Gasket	1	[R]
9994-61-000	Nut	2	[R]

WARRANTY INFORMATION

NOTE:

- This warranty information applies only to verified customer complaints on vehicles eligible for warranty repair.

CONSUMER NOTICE: The information and instructions in this bulletin are intended for use by skilled technicians. Mazda technicians utilize the proper tools/equipment and take training to correctly and safely maintain Mazda vehicles. These instructions should not be performed by "do-it-yourselfers." Customers should not assume this bulletin applies to their vehicle or that their vehicle will develop the described concern. To determine if the information applies, customers should contact their nearest authorized Mazda dealership. Mazda North American Operations reserves the right to alter the specifications and contents of this bulletin without obligation or advance notice. All rights reserved. No part of this bulletin may be reproduced in any form or by any means, electronic or mechanical---including photocopying and recording and the use of any kind of information storage and retrieval system ---without permission in writing.

- This repair will be covered under Mazda's New Vehicle Limited Warranty term.
- Additional diagnostic time cannot be claimed for this repair.

Warranty Type	A
Symptom Code	82
Damage Code	97
Part Number Main Cause	PY2B-40-100A
Quantity	1
Operation Number / Labor Hours:	XXR11XRX / 0.4 Hr. (includes main silencer RR)

CONSUMER NOTICE: The information and instructions in this bulletin are intended for use by skilled technicians. Mazda technicians utilize the proper tools/equipment and take training to correctly and safely maintain Mazda vehicles. These instructions should not be performed by "do-it-yourselfers." Customers should not assume this bulletin applies to their vehicle or that their vehicle will develop the described concern. To determine if the information applies, customers should contact their nearest authorized Mazda dealership. Mazda North American Operations reserves the right to alter the specifications and contents of this bulletin without obligation or advance notice. All rights reserved. No part of this bulletin may be reproduced in any form or by any means, electronic or mechanical---including photocopying and recording and the use of any kind of information storage and retrieval system ---without permission in writing.