

**February 21, 2019**

Version 3

## Product Update: Telematics Control Unit

Supersedes 19-017, dated February 2, 2019, to update the information highlighted in **yellow**.

### AFFECTED VEHICLES

Year	Model	Trim	VIN Range
2019	Passport	Elite, Touring	Check the iN VIN status for eligibility.

### REVISION SUMMARY

- Under PARTS INFORMATION, information was updated.
- Under REPAIR PROCEDURE, some steps were added.

### BACKGROUND

An incorrectly programmed telematics control unit (TCU) was installed in the vehicle, which may result in one or more of the following symptoms:

- HondaLink Services - Remote commands do not work, for example, remote door lock/unlock, virtual dashboard, safety and security services (automatic crash notification, eCall/911), etc.
- The Wi-Fi Hotspot connection doesn't work.
- Over the air (OTA) updates do not work.

### CORRECTIVE ACTION

Replace the TCU.

### PARTS INFORMATION

Part Name	Part Number	Quantity
Telematics Control Unit	39870-TGS-A11	1

#### NOTE

- VIN information will be required to order the part from the parts catalog.

**CUSTOMER INFORMATION:**The information in this bulletin is intended for use only by skilled technicians who have the proper tools, equipment, and training to correctly and safely maintain your vehicle. These procedures should not be attempted by "do-it-yourselfers," and you should not assume this bulletin applies to your vehicle, or that your vehicle has the condition described. To determine whether this information applies, contact an authorized Honda automobile dealer.

## WARRANTY CLAIM INFORMATION

Operation Number	Description	Flat Rate Time	Defect Code	Symptom Code	Template ID	Failed Part Number
0101P2	Replace the TCU.	0.5 hr	6TU00	J3Y00	A19017A	39870-TGS-A11

Skill Level: Repair Technician

## REPAIR PROCEDURE

1. Cover the steering wheel column and center console as shown with easy-release tape to avoid marring the vehicle.



2. Remove the driver's dashboard side lid and the driver's dashboard lower cover.



3. Remove the front passenger's dashboard side lid and the passenger's dashboard trim panel.

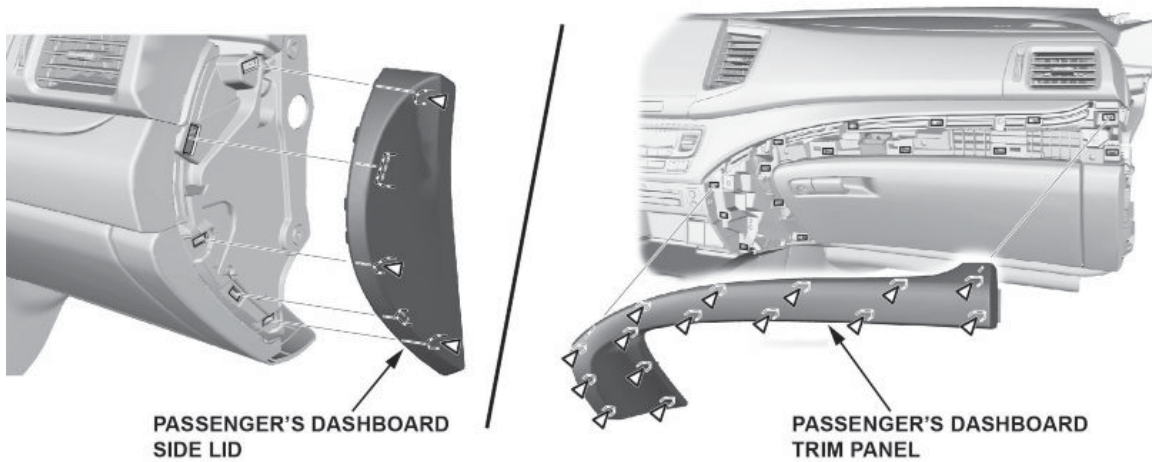

4. Remove the dashboard center panel.

4.1. Cover the area below the dashboard center panel with easy-release tape to avoid marring the vehicle.

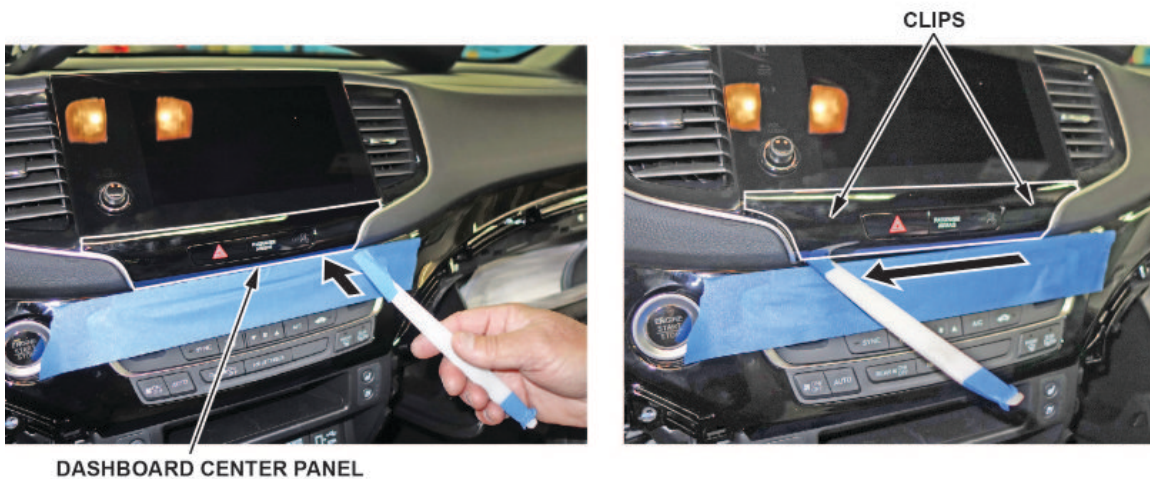

4.2. Wrap a small pry tool with tape.

4.3. Insert the pry tool at the right side, gently slide it across to the left side, and carefully twist/pry it to release the clip.

**NOTE**

Be careful when prying/removing the dashboard center panel so that it is not damaged or broken.

4.4. Carefully release the clip on both sides.



4.5. Disconnect the connector.



5. Remove the dashboard center middle trim.



SCREWS

DASHBOARD CENTER  
MIDDLE TRIM

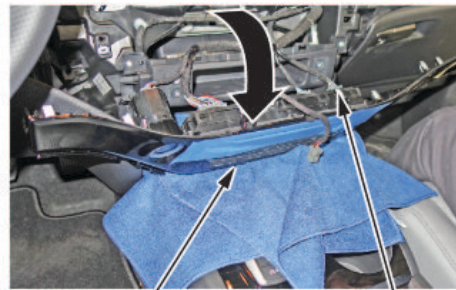

Rest the trim on a pad  
on the center console.

No need to  
disconnect  
connectors.

5.1. Remove the screws.

5.2. Remove the dashboard center middle trim, and place it on clean shop towels to protect from getting damaged.

#### NOTES

- You do not have to disconnect the connectors.
- You do not have to remove the glove box to remove the trim piece.

6. Pull the center display out of the dashboard:

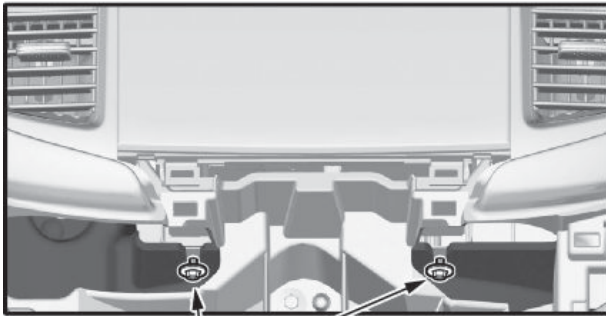

**MOUNTING SCREWS**  
4.4 N·m (3.2 lb-ft)



6.1. Loosen the screws.

6.2. Pull out the center display.

7. Remove the TCU.

7.1. To prevent damage, turn over the center display and place it on clean shop towels as shown. Then disconnect the four connectors from the TCU.

No need to disconnect connectors.



Flip the center display assembly over to access the TCU.



**TCU**



7.2. Remove the three screws from the bracket and slide the TCU out.

**NOTE**

To avoid confusing the original and replacement TCUs, use a permanent marker to place an "X" on the original TCU before removal.

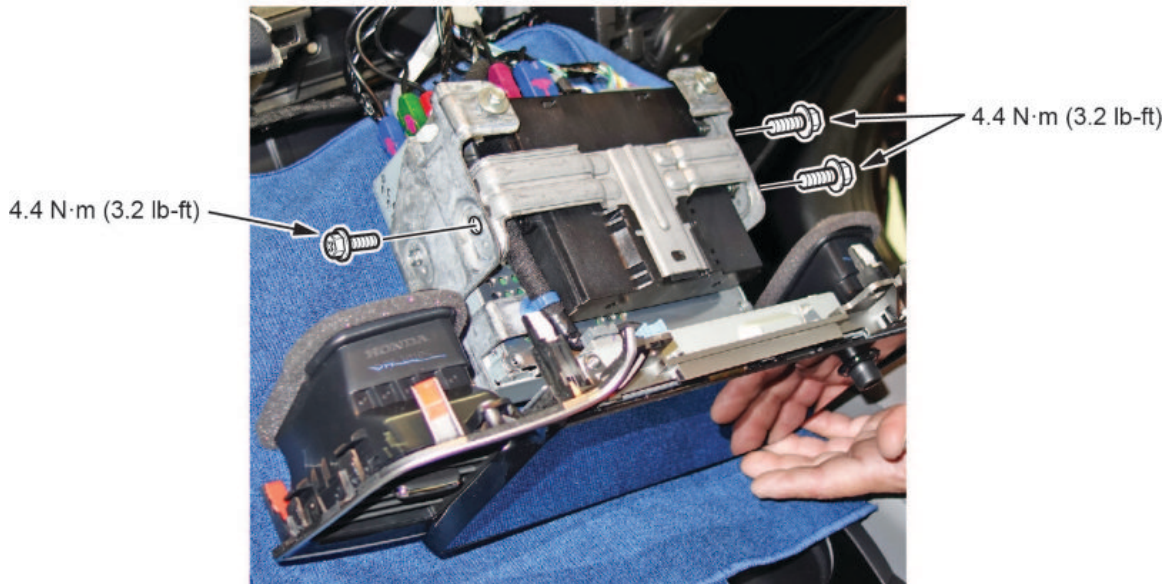

7.3. Remove the TCU bracket, and install it on the replacement TCU.

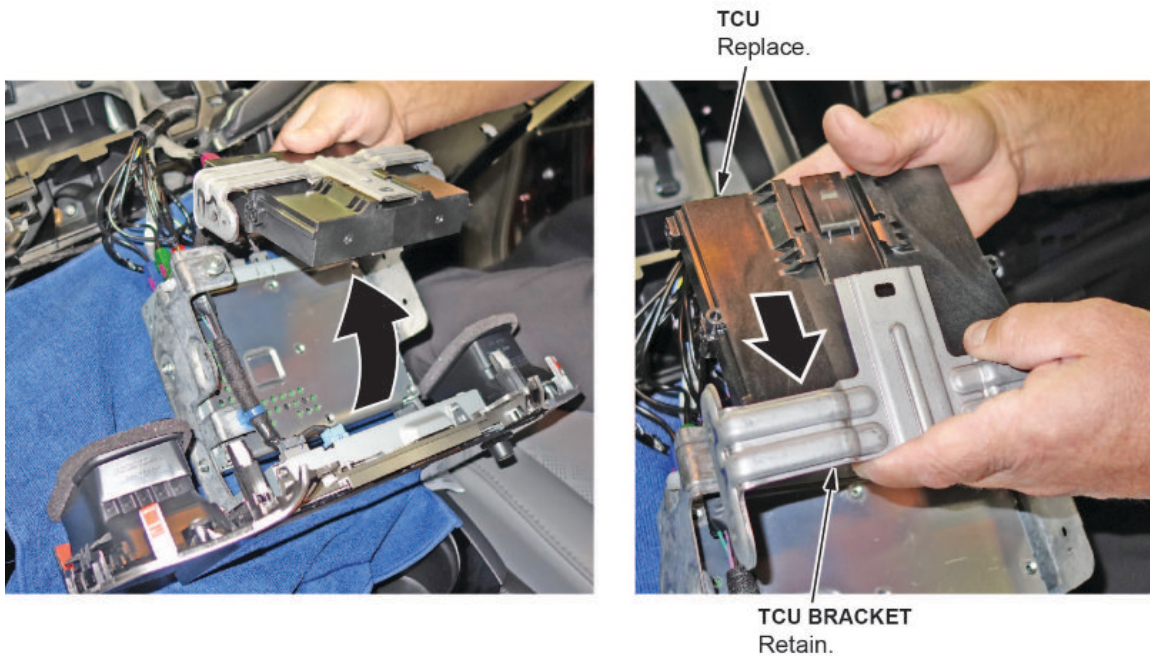

8. Install the replacement TCU.

9. Install the center display, the dashboard center panel, and all the remaining parts in the reverse order of removal.

**NOTE**

Make sure all the connectors are securely connected.

10. Move the vehicle to an open area away from trees, power lines, and tall buildings.
11. Make sure the transmission is in Park, and let the vehicle idle for at least **15 minutes** to re-establish the HondaLink service.

**NOTES**

- The TCU and the center display unit make a connection with the telematics provider every time the vehicle is turned ON. When the TCU is replaced, the TCU and the center display unit must be registered to each other. The registration process takes about **15 minutes** while the ignition is turned to ON.
  - If the ignition is turned to OFF during the registration process, the registration process restarts from the beginning every time the ignition is turned to ON.
12. After 15 minutes, turn the ignition to OFF, then back to ON. Confirm that the HondaLink indicator turns green.

**NOTE**

If the HondaLink indicator is red, check the TCU connectors.



END