



LTB00780NAS7

# TECHNICAL BULLETIN

09 JAN 2019

© Jaguar Land Rover North America, LLC

NOTE: The information in Technical Bulletins is intended for use by trained, professional Technicians with the knowledge, tools, and equipment required to do the job properly and safely. It informs these Technicians of conditions that may occur on some vehicles, or provides information that could assist in proper vehicle service. The procedures should not be performed by 'do-it-yourselfers'. If you are not a Retailer, do not assume that a condition described affects your vehicle. Contact an authorized Land Rover service facility to determine whether this bulletin applies to a specific vehicle.

## INFORMATION

**This reissue replaces all previous versions. Please destroy all previous versions.**

## SECTION:

303-05B / -05C

## SUBJECT/CONCERN:

Humming Noise From The Accessory Drive Belt Idler Pulley

## AFFECTED VEHICLE RANGE:

MODEL:

MODEL  
YEAR:

VIN:

APPLICABILITY:

MODEL:	MODEL YEAR:	VIN:	APPLICABILITY:
LR4 (LA)	2010-2016	510742-821203	V6 S/C 3.0L Petrol /V8 N/A 5.0L Petrol
Range Rover Sport (LW)	2014-2016	001154-652354	V6 S/C 3.0L Petrol /V8 S/C 5.0L Petrol
Range Rover (LG)	2013-2016	001204-286493	V6 S/C 3.0L Petrol /V8 N/A 5.0L Petrol/V8 S/C 5.0L Petrol
Range Rover Sport (LS)	2010-2013	208394-814822	V8 N/A 5.0L Petrol
Range Rover (LM)	2010-2012	303094-360037	V8 N/A 5.0L Petrol

## MARKETS:

NORTH AMERICA

## CONDITION SUMMARY:

### SITUATION:

A humming noise may be evident from the engine at idle.

### CAUSE:

This may be caused by dust and/or water ingress to the accessory drive belt idler pulley bearing.

### ACTION:

Should a customer express this concern, follow the Workshop Procedure below.

## PARTS:

PART NUMBER	DESCRIPTION	QUANTITY
LR099573	Idler pulley with bracket	1

**TOOLS:**

Refer to Workshop Manual/Service Instruction for any required special tools.

**WARRANTY:****△ NOTES:**

- Repair procedures are under constant review, and therefore times are subject to change; those quoted here must be taken as guidance only. Use TOPIx to obtain the latest repair time.
- The JLR claims submission system requires the use of causal part numbers. Labor only claims must show the causal part number with a quantity of zero.

DESCRIPTION	SRO	TIME (HOURS)	CONDITION CODE	CAUSAL PART
Idler pulley and bracket - Right - Accessory drive belt - Renew - LR4 (L319; V6 3.0L S/C Petrol)	12.10.52	0.2	42	LR010689
Idler pulley and bracket - Right - Accessory drive belt - Renew - LR4 (L319; V8 5.0L Petrol)	12.10.52	0.3	42	LR010689
Idler pulley and bracket - Right - Accessory drive belt - Renew - Range Rover Sport (L494)	12.10.52	0.2	42	LR010689
Idler pulley and bracket - Right - Accessory drive belt - Renew - Range Rover Sport (L320)	12.10.52	0.3	42	LR010689
Idler pulley and bracket - Right - Accessory drive belt - Renew - Range Rover (L405)	12.10.52	0.2	42	LR010689
Idler pulley and bracket - Right - Accessory drive belt - Renew - Range Rover (L322)	12.10.52	0.2	42	LR010689

**NOTE:**

Normal Warranty procedures apply.

**WORKSHOP PROCEDURE:****CAUTION:**

The idler pulley with bracket **MUST** be replaced as a set. Installing the new idler pulley onto the old bracket or the new bracket to the old Idler pulley could introduce a misalignment.

- 1 Remove the T-connector from the air cleaner outlet pipe (see TOPIx Workshop Manual section 303-12: Intake Air Distribution and Filtering).

2

**NOTE:**

Note the installed position of the accessory drive belt.

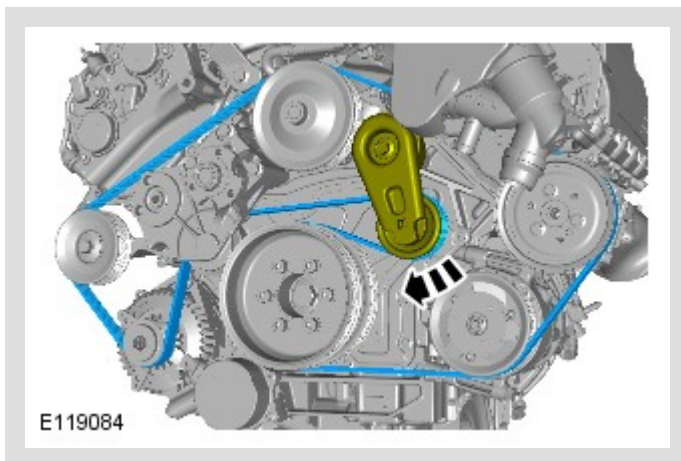

Loosen the accessory drive belt and remove from the idler pulley.

3

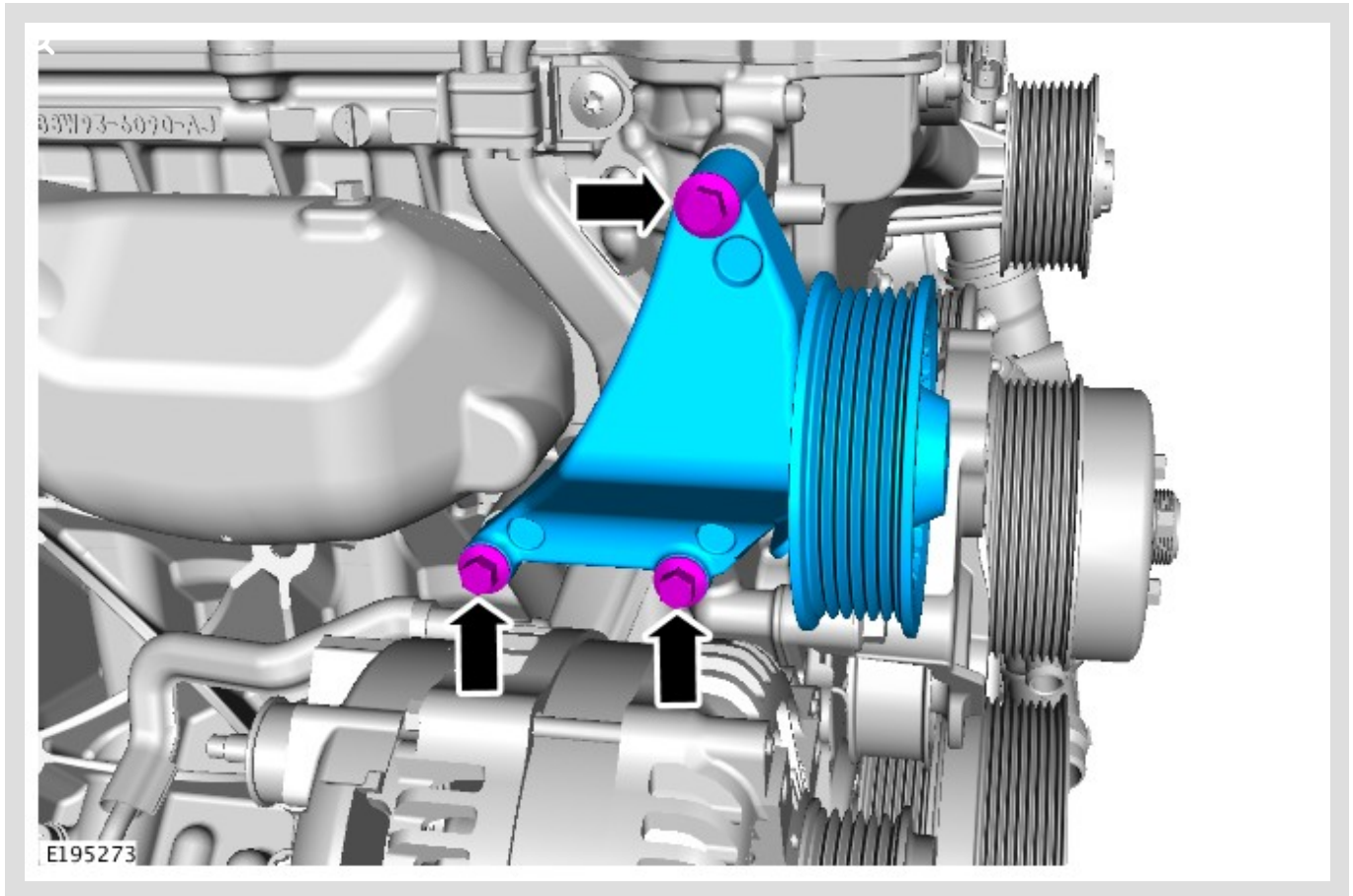

Remove the accessory drive belt Idler pulley and bracket assembly.

- Retain the fasteners.

4

**ⓘ CAUTION:**

The idler pulley with bracket **MUST** be replaced as a set. Installing the new idler pulley onto the old bracket or the new bracket to the old Idler pulley could introduce a misalignment.

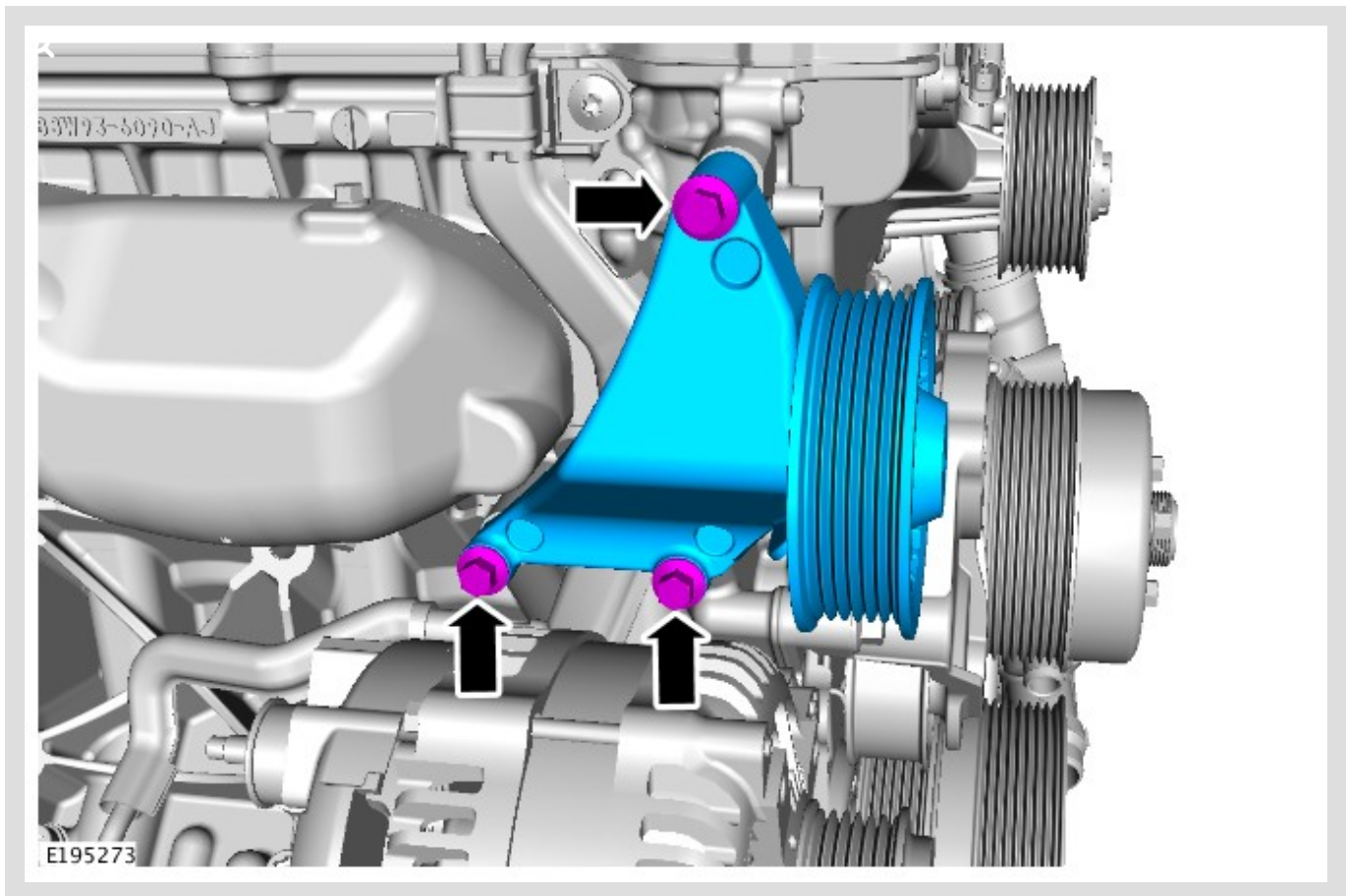

Install the new accessory drive belt pulley and bracket assembly.

- Torque: **25Nm**

5

**ⓘ CAUTION:**

Make sure that the accessory drive belt is correctly located on each pulley.

Install the accessory drive belt.

6

Install the T-connector from the air cleaner outlet pipe (see TOPIx Workshop Manual section 303-12: Intake Air Distribution and Filtering).