



Replace Huck BOM Fastener on Model S Base Front Seats

Classification Repair Bulletin **Section/Group** 13 - Seats **Country/Region** All

Year 2012-2018 **Model** Model S **Version** All

Bulletin Classification: *This repair bulletin provides instructions and guidelines for a noted condition or a customer concern. The information provided can address a broad range of known or perceived issues with the operation of Tesla vehicles. This bulletin might not be VIN-specific. These instructions assume knowledge of motor vehicle and high voltage electrical component repairs, and should only be executed by trained professionals. Tesla assumes no liability for injury or property damage due to a failure to properly follow these instructions or repairs attempted by unqualified individuals.*

This Service Bulletin supersedes SB-18-13-002, dated 19-Jul-18. Each content change is marked by a vertical line in the left margin. Discard the previous version and replace it with this one.

Condition

On some Model S base trim front seats, the forward inboard Huck BOM fastener and pivot bushing (nearest to the center console) used on the front lift links may develop an interactive clearance condition, which might result in a rocking motion in the seat. This does not affect performance, but might result in customer dissatisfaction.

Correction

Upon customer complaint of front seats that rock when occupied, remove and discard the original Huck BOM fastener, and install a new pivot bolt and bushing.

Correction Description	Correction	Time
SB-18-13-002 Not Applicable	S011813002	0.00
Remove Huck BOM Fastener, And Install Bushing And Pivot Bolt On LH Front Seat	S021813002	1.05
Remove Huck BOM Fastener, And Install Bushing And Pivot Bolt On RH Front Seat	S031813002	1.05
Remove Huck BOM Fastener, And Install Bushing And Pivot Bolt On LH and RH Front Seats	S041813002	2.10

Required Part(s):	Part Number	Description	Quantity
	1452393-00-B	SERVICE KIT - HUCKBOM REPAIR	1
	These part numbers were current at the time of publication. Use the revisions listed or later, unless otherwise specified in the Parts Manual.		
Special Tool(s):	1137575-00-A	KIT, HUCK BOM REPLACEMENT	

Procedure

NOTE: This procedure is for Model S base trim 1st row seats. A base trim seat does not have a powered headrest. To replace the Huck BOM fastener on Model S Premium 1st row seats or Model X 1st row seats, refer to SB-17-13-005, "Replace Huck BOM Fastener on Front Seats".

⚠ WARNING: To reduce the risk of personal injury, eye protection and cut-resistant gloves must be worn while performing this procedure.

⚠ CAUTION: To make sure the new fastener fits properly, use only drill bits from the Huck BOM Replacement kit and apply drilling compound to the drill bit while performing this procedure.

1. Remove the front seat (refer to Service Manual procedure 13040101).
2. Move the seat to a clean, flat work area.
3. Remove the front seat memory module (refer to Service Manual procedure 13010602).
4. Disconnect seat track motor connector (Figure 1).

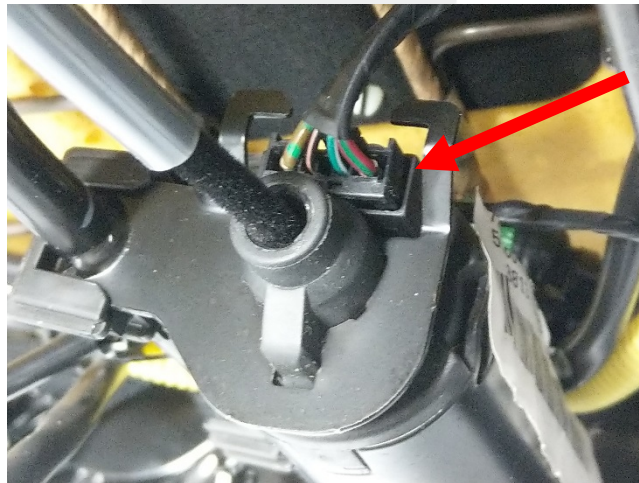

Figure 1

5. Remove the nuts (x8) that attach the tracks to the seat (Figure 2 and Figure 3) (torque 28 Nm).

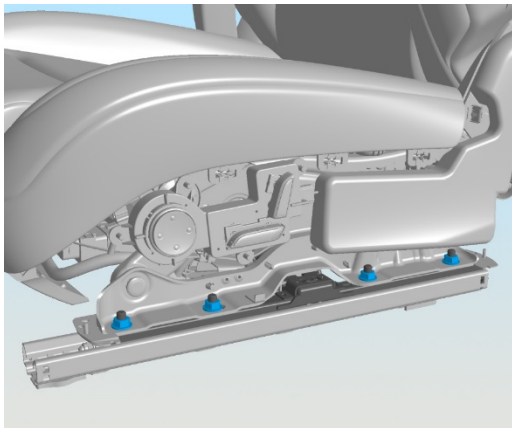

Figure 2

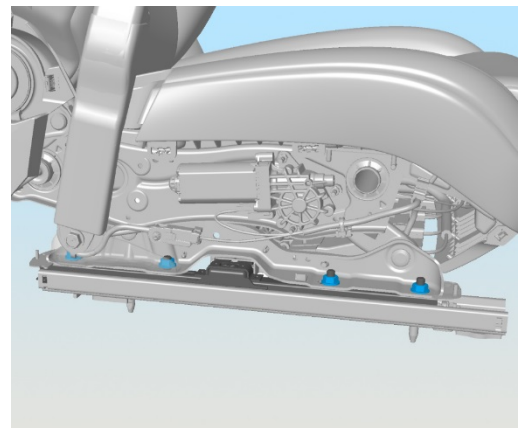

Figure 3

6. Slide the outboard track out of the position sensor and remove both tracks from the seat.

7. Remove the Huck BOM fastener:

- a. Locate the Huck BOM rivet on the inboard side (closest to the center console) of the seat frame (Figure 4).



Figure 4

- b. Get a 1/4 in drill bit from the Huck BOM Replacement kit, and insert it in a drill.

⚠ CAUTION: To make sure the new fastener fits properly, use only drill bits from the Huck BOM Replacement kit while performing this procedure.

- c. Apply drill compound to the bit.
- d. Position the 1/4 in drill jig over the head of the Huck BOM (Figure 5).



Figure 5

- e. Using the jig as a guide, drill a pilot hole through the Huck BOM (Figure 6).



Figure 6

- f. Insert the 21/64 in drill bit from the Huck BOM Replacement kit in a drill.
- g. Apply drill compound to the bit.
- h. Position the 21/64 in drill jig over the head of the Huck BOM fastener and drill until the Huck BOM body detaches from the head (Figure 7).



Figure 7

- i. Remove and discard the Huck BOM body and head.
- 8. Remove any debris from the work area.
 - 9. Move the inner seat arm away from the seat base (Figure 8).



Figure 8

10. Install the new bushing:

- a. Insert the 3/8 in drill bit from the Huck BOM Replacement kit in a drill.
- b. Drill out the bushing (Figure 9).



Figure 9

TIP: If the bushing starts to spin, stop drilling and remove the bushing by hand.

- c. If necessary, use a file to smooth the edges of the hole.
- d. Remove the flare tool from the Huck BOM Replacement kit.

NOTE: The main parts of the flare tool (Figure 10) are:

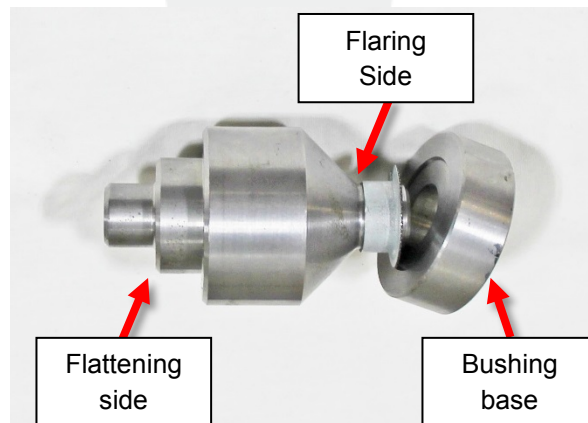

Figure 10

- e. Insert a new bushing into the seat base, with the flange of the bushing on the inboard side of the base (Figure 11).



Figure 11

- f. Insert the flaring side of the tool into the outboard side of the bushing and place the bushing base of the tool over the bushing flange (Figure 12).

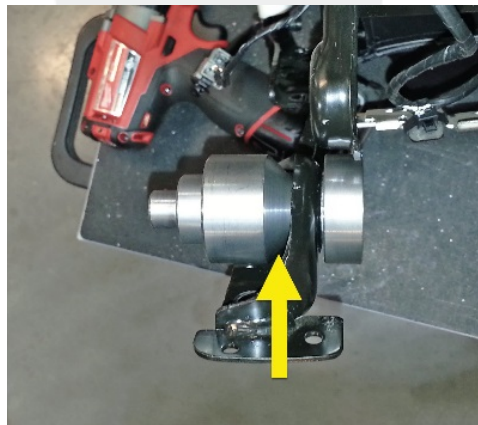

Figure 12

- g. Apply the C-clamp (Figure 13) to the flare tool and continue to tighten the clamp until the bushing body flares over the edge of the hole (Figure 14).



Figure 13



Figure 14

- h. Remove the C-clamp and put the end of the flattening side of the tool into the flared part of the bushing body (Figure 15).

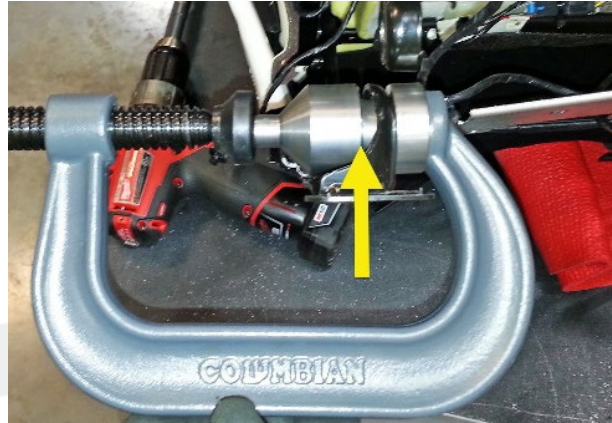

Figure 15

- i. Tighten the C-clamp to flatten the bushing body into a flange on the outboard side of the seat track (Figure 16).



Figure 16

NOTE: The newly formed flange might or might not be split, as shown in Figure 16.

- j. Remove the C-clamp.

11. Enlarge the hole in the upper seat arm:

- a. Insert the 21/64 in drill bit from the Huck BOM Replacement kit in a drill and apply drilling compound.
- b. Drill out the hole in the upper seat arm to (Figure 17).



Figure 17

- c. If necessary, use a file to smooth the edges of the hole.
12. Realign the inner seat arm with the seat frame and install a new pivot bolt, with the head of the bolt on the outboard side of the seat frame.
13. Install a star lock washer and Nyloc nut on the pivot bolt.
14. Hold the Nyloc nut in position, then use a T-40 socket to torque the bolt to 30 Nm (Figure 18).

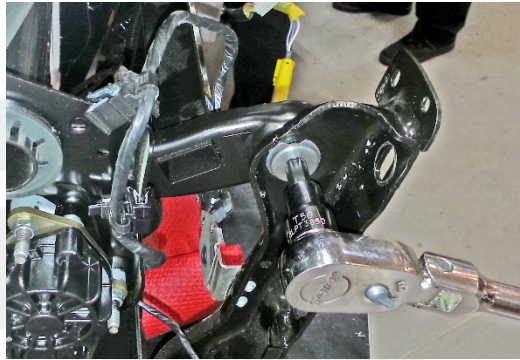

Figure 18

⚠ CAUTION: Use only a hand-held torque wrench to tighten the pivot bolt. Do not exceed 30 Nm of torque on the pivot bolt.

15. Slide the outboard track into the position sensor and position it on the seat.
16. Position the inboard track on the seat.
17. Install the nuts (x8) that secure the tracks to the seat (torque 28 Nm).
18. Connect the seat track motor connector.
19. Reinstall the front seat memory module (refer to Service Manual procedure 13010602).
20. Reinstall the seat (refer to Service Manual procedure 13040101).
21. If necessary, repeat this procedure on the other seat.

Affected VIN(s) Affected Model S vehicles with base 1st row seats built before approximately February 14, 2018.

NOTE: This is a simplified summary of the affected VIN list. Refer to the VIN/Bulletin Tracker or Customer/Vehicle profile to determine applicability of this bulletin for a particular vehicle.

For feedback on the accuracy of this document, email ServiceBulletinFeedback@tesla.com.