

# PREVOST

## Instruction Sheet

## IS-19910

### ELECTRIC FAN DRIVE COOLING SYSTEM CONVERSION WITH DELCO-REMY ALTERNATOR - H3 SERIES US10





REVISION : THIS DOCUMENT SUPERSEDES PREVIOUS VERSION.  
NONE



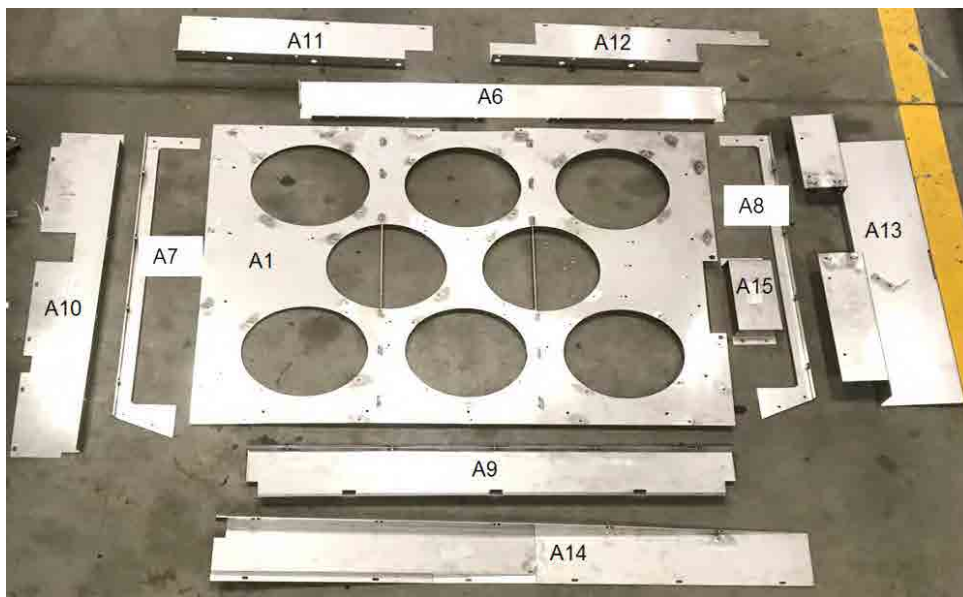

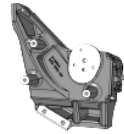
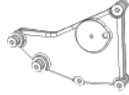

#### MATERIAL







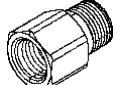
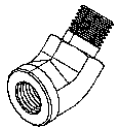

Kit **IS19910** "H3 US10 electric fan drive retrofit" contains the following parts:







Part No.	DESCRIPTION		Qty
050195	FAN SUPPORT PANEL	A1	1
050200	UPPER SHROUD TRANSITION	A6	1
050201	LEFT SHROUD TRANSITION	A7	1
050202	RIGHT SHROUD TRANSITION	A8	1
050203	LOWER SHROUD TRANSITION	A9	1
050204	UPPER LEFT SHROUD PANEL H3 US10+	A11	1
050229	ELECTRICAL CONNECTOR COVER	A15	1
050206	UPPER RIGHT SHROUD PANEL H3 US10+	A12	1
050213	LOWER SHROUD PANEL H3 US10+	A14	1
050208	LH SIDE SHROUD PANEL H3 US10+	A10	1
050255	RH SIDE SHROUD PANEL & WURTH BOX SUPPORT H3 US10+	A13	1

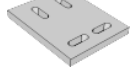
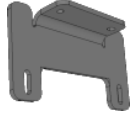



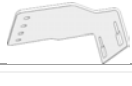
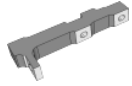



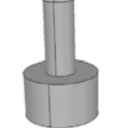

012349	IDLER PULLEY	Mechanical 	1
012941	PULLEY, DRIVE	Mechanical 	1
010090	L.H. ENGINE MOUNT	Mechanical 	1
012943	SUPPORT, IDLER + TENSIONER	Mechanical 	1
069893	PULLEY, DELCO REMY ALTERNATOR 10PK 69 DOB	Mechanical 	1
453076	CAP, DUST	Mechanical 	1

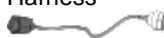

506067	1x BELT 10PK1703 ARAMIDE 1x BELT 10PK1703 ARAMIDE (for your spare kit)	Mechanical 	2
510991	TENSIONER, BELT	Mechanical 	1
560720	DELCO REMY ALTERNATOR 55SI 24V-250A	Mechanical 	1
050286	CAC INLET PIPE H3 US10+	Pipe 	1
050406	CAC OUTLET PIPE H3 US10+	Pipe 	1
050414	RADIATOR INLET COOLANT PIPE H3 US10+	Pipe 	1
050288	RADIATOR OUTLET PIPE H3 US10+	Pipe 	1
501027	FITTING, SAE 45° #4FL-Mx1/4NPT-M BR	Fitting 	1
501308	ADAPTER / PIPE FITTING / 1/4NPT-Fx1/4NPT-M BR	Fitting 	1
501329	ELBOW 45° / PIPE FITTING / 1/4NPT-Mx1/4NPT-F BR	Fitting 	1
501332	ELBOW 90° / PIPE FITTING / 1/4NPT-Mx1/4NPT-F BR	Fitting 	1
052366	HOSE 3/8 ID X 61" LONG	hose	1
20550690	HOSE, FLEXIBLE - CHARGE AIR Location: turbo outlet & engine intake	Hose 	2

531469	HOSE, FLEXIBLE - CHARGE AIR Location: CAC outlet	Hose 	1
531471	HOSE, FLEXIBLE - CHARGE AIR Location: CAC inlet	Hose 	1
052889	HOSE, SILICONE 2 1/2" ID Location : coolant pipes	Hose 	1
053617	HOSE, SILICONE Location : coolant pipes	Hose 	3
21490616	CLAMPS, SPRING LOAD - CHARGE AIR Location: CAC outlet & inlet	Clamps 	8
21490630	CLAMP, SPRING LOAD - CHARGE AIR Location: turbo outlet & engine intake	Clamps 	4
992089	HOSE CLAMP CT CAILLAU 60mm-80mm Location : coolant pipes	Clamps 	16
992081	HOSE CLAMP CT CAILLAU 12-22 Location : coolant filter	Clamps 	4
21185073	MOUNT, ANTI-VIBRATION	Support /bracket 	1
050305	BRACKET, RADIATOR INLET PIPE	Support /bracket 	1

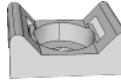
050265	COOLANT FILTER SUPPORT H3	Support /bracket 	1
050303	ALTERNATOR TELLTALE BRACKET	Support /bracket 	1
050214	UPPER RADIATOR SUPPORT H3	Support /bracket 	1
069890	LH LOWER ALTERNATEUR SUPPORT	Support /bracket 	1
069891	LH UPPER ALTERNATEUR SUPPORT	Support /bracket 	1
069205	DECAL, WARNING	Misc. 	2
010111	DECAL, BELT	Misc. 	1
391028	INSERT, ALTERNATOR TELLTALE	Misc.	1
506025	RUBBER EXTRUSION, BLACK	Misc. 	8 ft
380360	GROUND STUD	Misc. 	1
506040	TAPE, ADHESIVE AD1 EPDM CC GY 5/16"X3/4"X25'	Misc.	1
562113	TELLTALE LIGHT MODULE	Misc.	1

21937327	FILTER, COOLANT	Misc. 	1
012921	GROUND STUD	Electrical 	1
561610	CONNECTOR HOUSING, PED WEATHER-PACK 4 WIRES	Electrical 	1
561783	CAVITY PLUG, CONNECTOR	Electrical 	4
22722850	I/O-B MULTIPLEX MODULE	Electrical 	1
23499009_EFD	MCM, PROGRAMMED	Electrical	1
563593	CONNECTOR, WITH END-OF-LINE 120 OHMS RESISTOR	Electrical 	2
563750	FUSE HOLDER, AMG TYPE	Electrical 	1
564520	FUSE, AMG 300A	Electrical 	1
564612	CIRCUIT BREAKER BOX, WURTH	Electrical 	1
565191	FAN, ELECTRIC	Electrical 	8

563533	HAND GUARD, FAN	Electrical 	8
23498721	FAN DRIVE POWER CABLE, 4600mm	Harness	1
23524934	L.H. ALTERNATOR POWER CABLE – DELCO REMY	Harness	1
23498450	MASTER RELAY TO 300A FUSE CABLE, 300mm	Harness	1
23445869	MCM TO I/O-B INTERFACE HARNESS	Harness	1
23488790	FAN TO RJB INTERFACE HARNESS H3	Harness	1
23490553	VEHICLE INTERFACE HARNESS	Harness	1
068820	HARNESS, FAN DRIVE	Harness 	1
069246	GROUND CABLE, FAN DRIVE	Harness 	1
0610037	CONTROL HARNESS, LEFT ALTERNATOR	Harness 	1
0610035	GROUND CABLE, LEFT ALTERNATOR	Harness 	1
N37749	TIE, NYLON, DOUBLE	hardware 	15
509491	TIE, NYLON LARGE EXTRA STRONG 250 LBS	hardware 	38
504016	TIE, NYLON BLACK (LARGE)	hardware 	58
504013	MOUNT, TIE HOLE 1/4"	hardware 	25
504751	MOUNT, TIE SWIVEL	hardware 	4

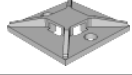
504750	MOUNT, TIE TREE	 hardware	1
509490	MOUNT, TIE DOUBLE GRAY	 hardware	15
562679	MOUNT, SQUARE SELF-ADHESIVE BLACK	 hardware	4
500411	WSH FL SS .260X.697X.05 (M6,1/4)	hardware	1
500449	WASHER, FLAT SS .687X1.5X0.078 (M16,5/8)	hardware	1
500482	WASHER, SPLIT LOCK Z050 .506X.873X.125 (M12,1/2)	hardware	1
500942	WASHER, SPLIT LOCK N500 8.1X14.8X2 (M8,5/16,#18)	hardware	4
502570	WASHER, SPLIT LOCK SS 6.1X11.8X1.6 (M6,#12)	hardware	62
502573	WASHER FL SS 6.4 X 12.0 X 1.6 (M6,1/4)	hardware	1
507657	WASHER, BANJO FITTING M14	hardware	8
5001137	WSH FL SS .203X.438X.06 (M5,#10)	hardware	2
5001341	WASHER, FLAT SS 8.4X17X1.6 (M8,5/16)	hardware	7
5001737	WASHER, SPLIT LOCK N500 10.2X18.1X2.2 (M10,3/8)	hardware	4
5001751	WASHER, FLAT N500 10.5X26X2 (M10,3/8)	hardware	10
5001833	WASHER, BELLEVILLE SPR SS 301 6.65X17.4X1.27(M6,1/4)	hardware	32
5001868	WASHER, BELLEVILLE SS 8.4X18X2 (M8,5/16)	hardware	4
5001935	WASHER, FLAT SS 10.5X18X1.6 (M10,3/8)	hardware	1
5002008	WASHER, FLAT HARD N500 13X35X5 (M12,1/2)	hardware	1
500998	NUT HEX BR 1/2-13	hardware	1
502837	NUT HEXF STO N500 M8-1.25	hardware	2
502859	NUT HEX NYRT NX500 M10-1.5 G10	hardware	4
5001180	NUT HEX NYRT SS 10-24	hardware	2

5001182	NUT HEX NYRT SS M6-1	hardware	1
5001665	NUT HEX NYRT NX500 M22-2.5	hardware	1
5001761	NUT HEXF NYRT NX500 M12-1.75 G8	hardware	2
5001930	NUT HEXF NYRT NX500 M10-1.50 PC 10	hardware	2
5001983	NUT HEX NYRT NSS M8-1.25	hardware	3
500685	NUT HEX NYRT SS 5/16-18	hardware	1
500119	SCREW, CAP HEX SS NSS M8X1.25X20	hardware	4
500658	SCREW TC PAN PH Z050 10-24X3/4	hardware	11
502719	SCREW, CAP HEX SS NSS M10X20 G8.8	hardware	1
502686	SCREW, CAP HEX SS NSS M6X30	hardware	33
502804	SCREW, CAP HEX N500 M10-1.5X25 G8.8	hardware	8
502848	SCREW TC HEX F N500 1/4-20X3/	hardware	22
5001296	SCREW, CAP HEXFN500 M12-1.75 X 80 CL10.9 PT	hardware	6
5001308	SCR CAP HEXF N500 M10-1.5X40 G10.9	hardware	4
5001643	SCREW, CAP HEXF G500 M8-1.25X25 G8.8 PT	hardware	3
5001697	SCREW, CAP HEX SS NSS M6X16	hardware	62
5001738	SCREW, CAP HEX N500 M8X30 G8.8 FT	hardware	4
5001745	SCREW, CAP HEX N500 M8-1.25X25 G8.8	hardware	2
5001786	SCREW, CAP HEXF AD N500 M12-1.75X30 G8.8	hardware	1
5001799	SCREW, CAP HEXF N500 M10-1.5 X 70 G10.9	hardware	4
5001940	SCREW CAP HEX N500 M12X1.75X140	hardware	2
5002091	SCR CAP HEXF N500 M10-1.5X120 G10.9	hardware	4
504379	RIVET, POP DOME SS OE 3/16X1/4	hardware 	41
504610	RIVET MGL PRDG SS 1/4X5/8	hardware 	14
IS-19910	INSTRUCTION SHEET		1

# PREVOST

## NOTE

*Material can be obtained through regular channels.*

## PROCEDURE



### **DANGER**

Park vehicle safely, apply parking brake, stop engine. Prior to working on the vehicle, set the ignition switch to the OFF position and trip the main circuit breakers equipped with a trip button.

## ELECTRICAL CABLES & HARNESSES DIAGRAM

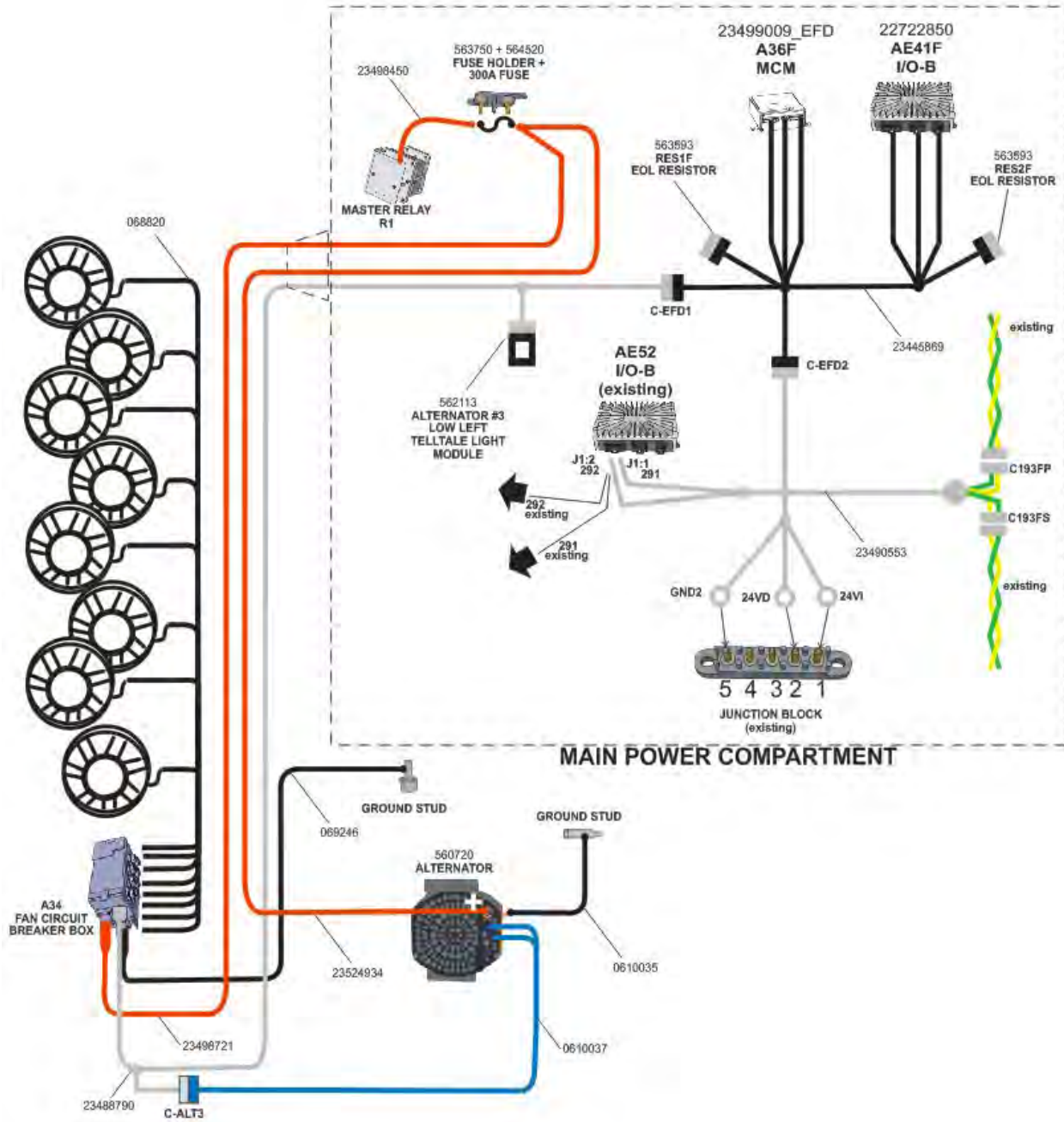

### HOSE CLAMP TORQUE (coolant lines and charge air cooler)

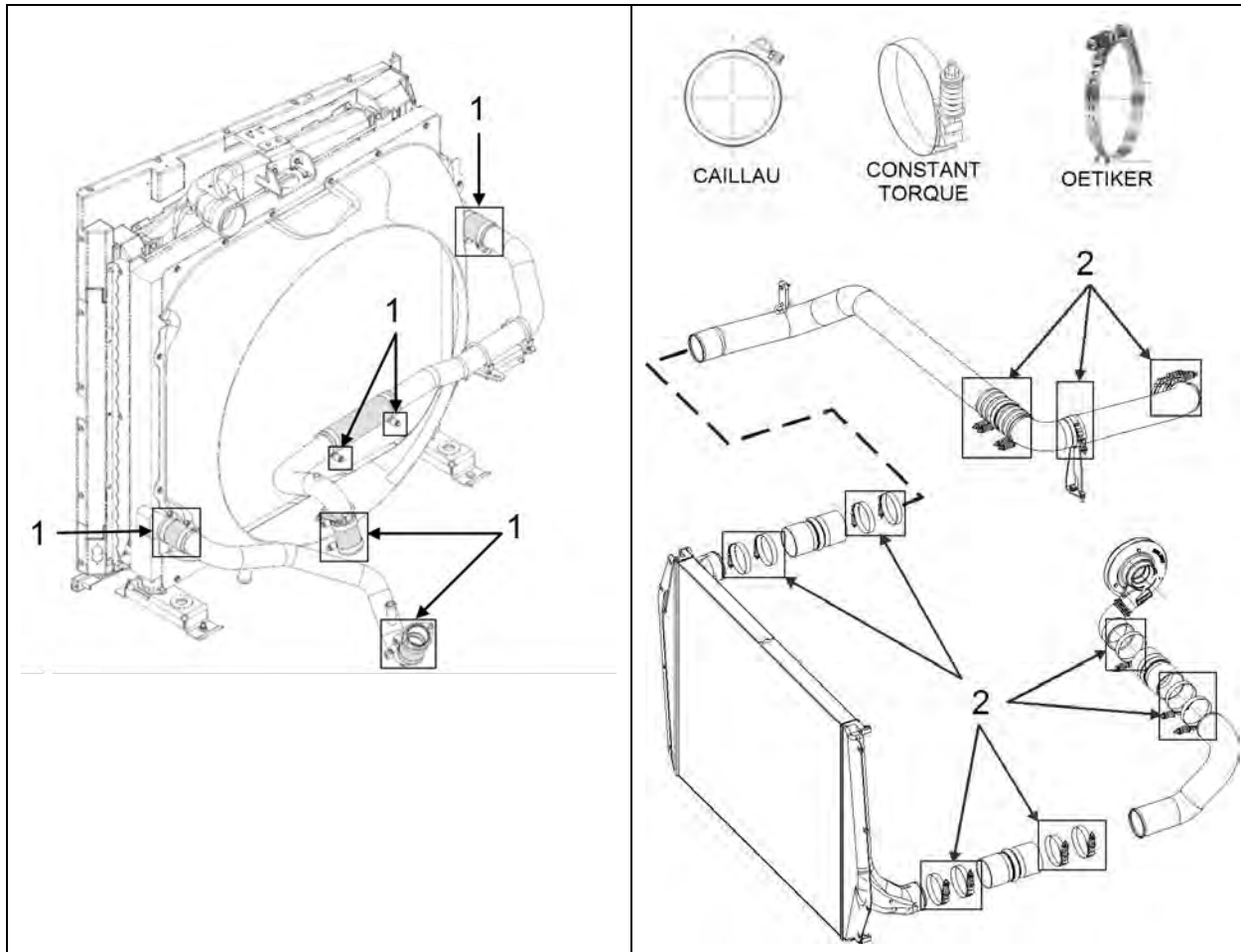

#### HOSE CLAMPS

No	DESCRIPTION	TORQUE
1 (Ø 2 ½ " or lower)	Constant-Torque hose clamps - coolant lines	90-100 lbf-in
	Oetiker hose clamps – Green spring - coolant lines	12-18 lbf-in
	Oetiker hose clamps – unpainted spring - coolant lines	8-9 lbf-in
	Caillau hose clamps - coolant lines	30 lbf-in
2 (Ø 4 ¼ ")	Constant-Torque hose clamps 4.25in - charge air cooler (CAC)	4.5-5.5 lbf-ft

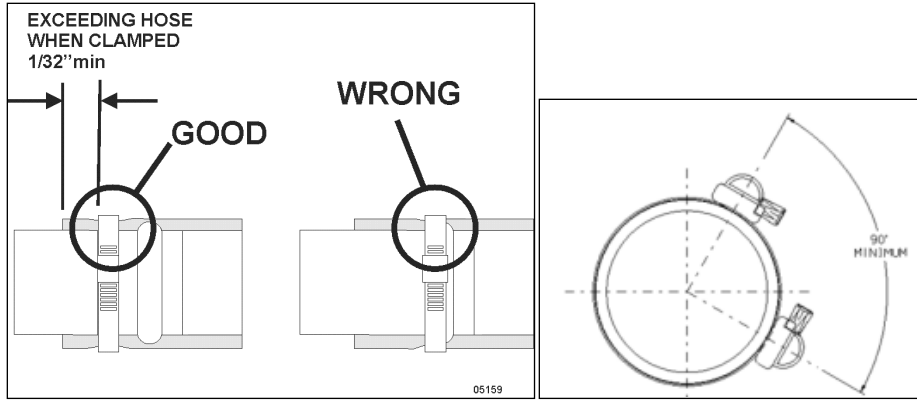

# PREVOST

1. Remove L.H. side rear fender.

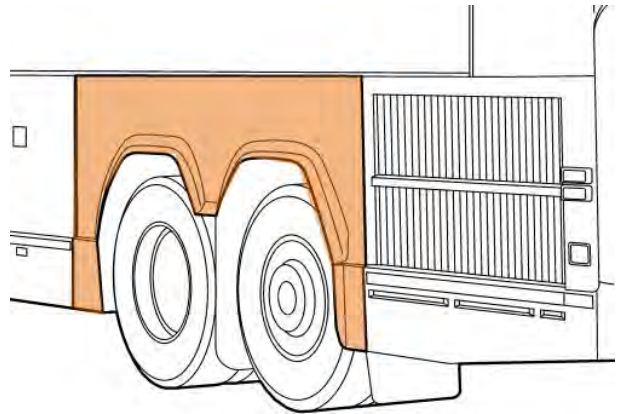

FIGURE 1

## Drain the cooling system

2. Connect the coolant extractor. Use the coolant extractor to drain the coolant from the engine. An alternate method is to drain the coolant into a suitable container using the drain hose.

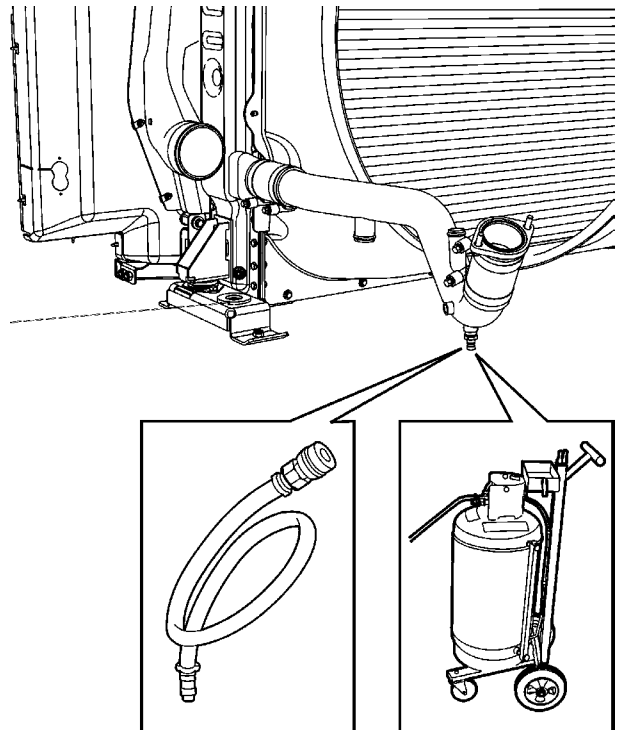

FIGURE 2

3. Unfasten cap screws and remove **access panel** located behind tag axle L.H. side wheel.

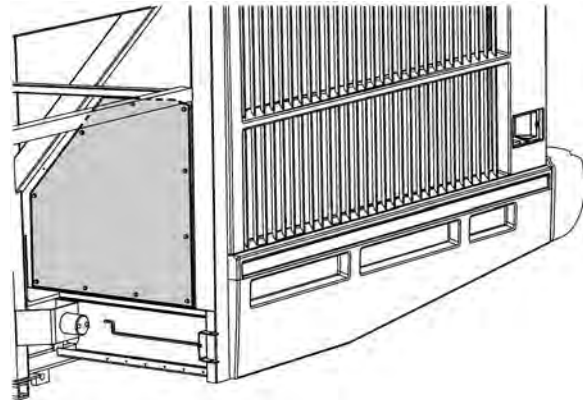

FIGURE 3

4. Open radiator door to access radiator assembly. Unfasten **upper arm assembly**.

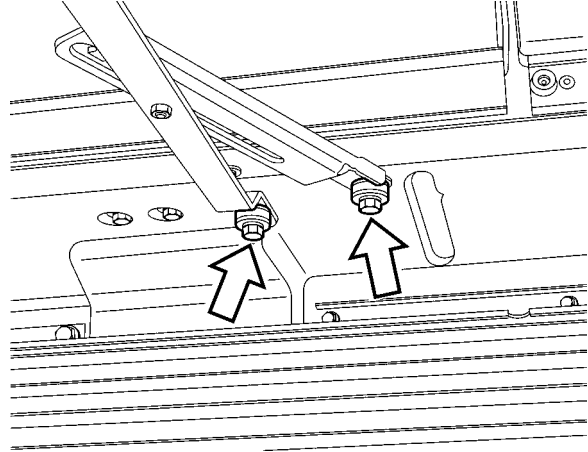

FIGURE 4

5. Remove radiator **sealing frame**.

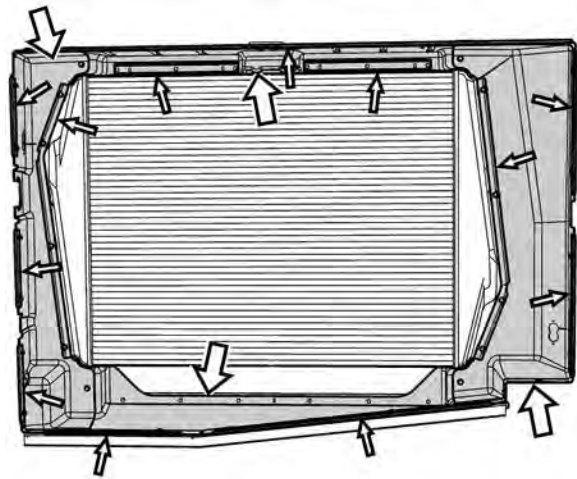

FIGURE 5

6. **Remove clamps** and then break hoses from the front coolant and charge air pipes.

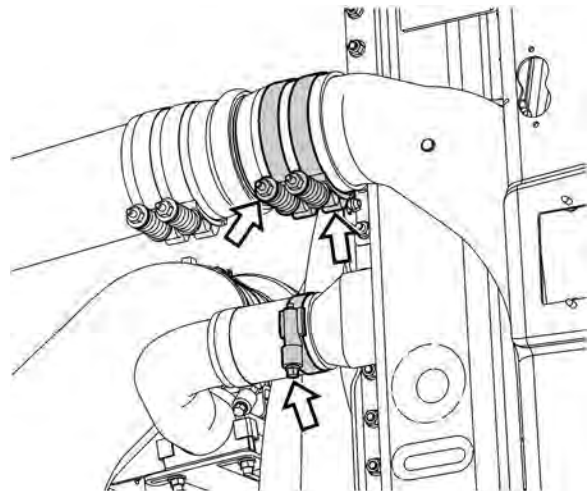

FIGURE 6

7. **Remove** rear coolant and charge air hose **clamps** then break hoses loose.

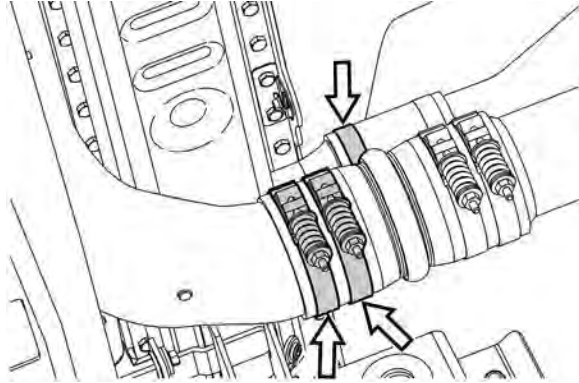

FIGURE 7

8. Remove the upper radiator assembly **support bracket**.

*Keep the three small (3) rectangular plates for reuse*

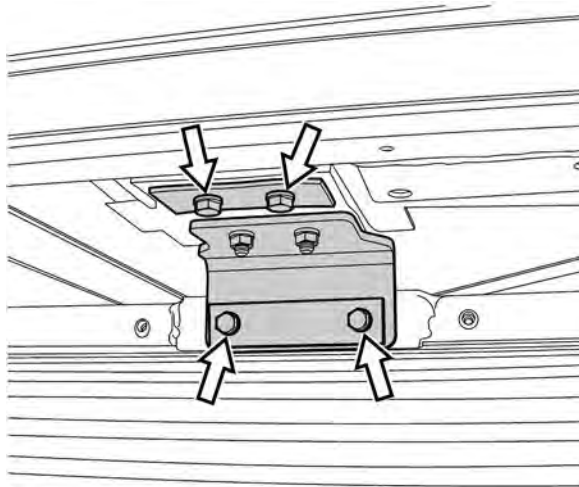

FIGURE 8

9. Remove the lower radiator assembly protector tube.

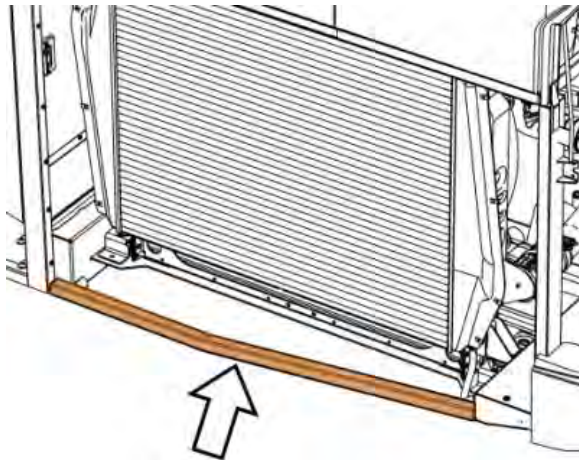
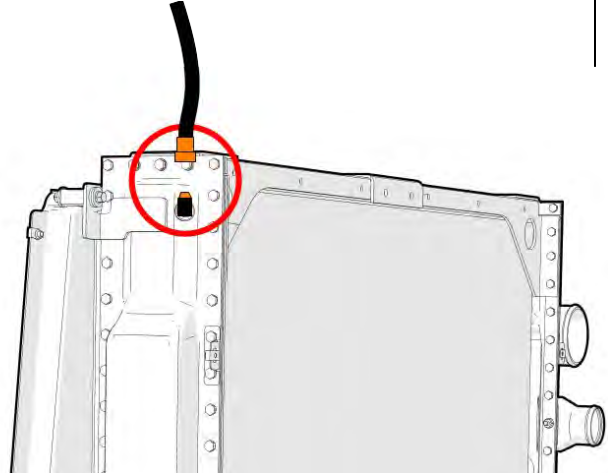

FIGURE 9

10. Disconnect the **radiator vent hose** on top of the radiator.



11. Cut the cable tie and disconnect **electrical connector** from the fan clutch. The remaining connector on the chassis cable will be capped and left in place.

12. Remove fan **drive shaft** fasteners at the fan clutch.

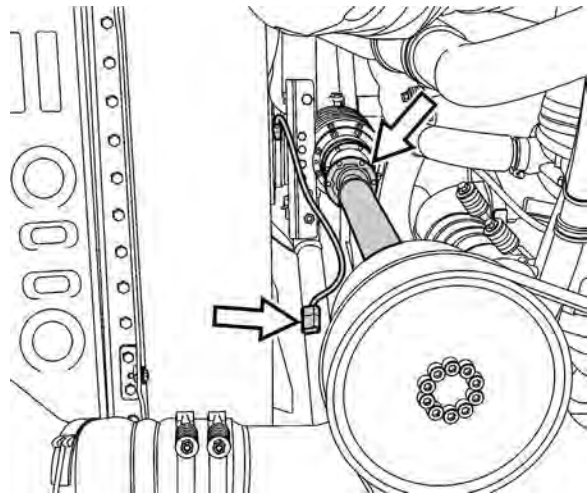

FIGURE 10

13. Open the secondary lock of **connector #561610**. Insert a **cavity plug #561783** in each of the four (4) cavities with the smallest end protruding as shown on the example at right. Close the secondary lock.



FIGURE 11

14. Cap the chassis fan clutch cable with this connector. Secure the connector on the inner wall above the radiator using:

- *1x tree mount #504750*
- *1x nylon tie #504016*



FIGURE 12



FIGURE 13

15. Remove the fan drive casting.



FIGURE 14

16. Unscrew all lower radiator assembly **mounting fasteners** (2 bolts on R.H. side, 2 bolts on L.H. side).

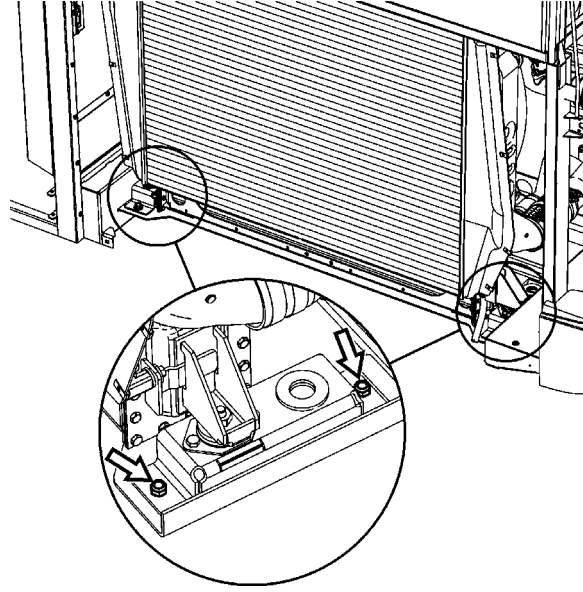

FIGURE 15

17. Position a **forklift** under the radiator assembly that is capable of safely lifting the radiator. With assistance, slide radiator assembly out and onto the forklift. Transfer radiator assembly to a secure location.

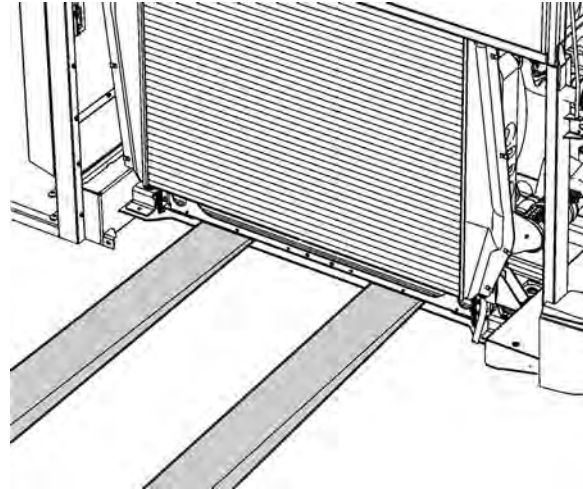

FIGURE 16

18. Remove the **tripod** from the radiator/CAC assembly.

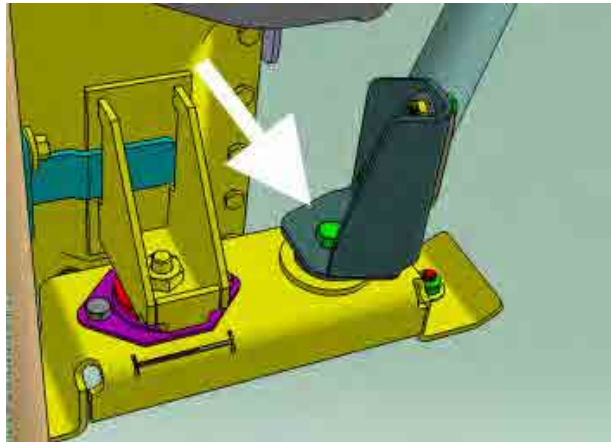

FIGURE 17

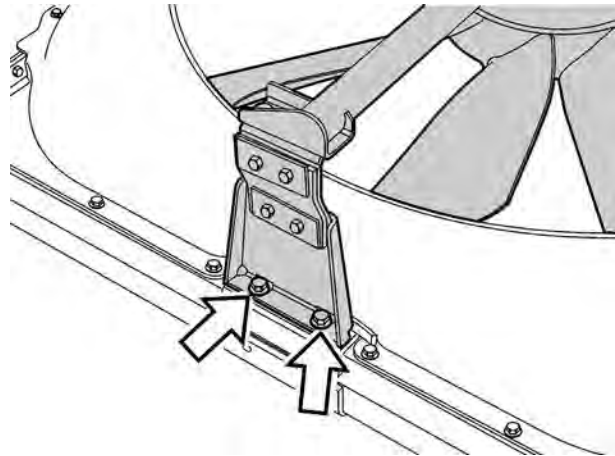

FIGURE 18

19. Remove the fan **shroud**.

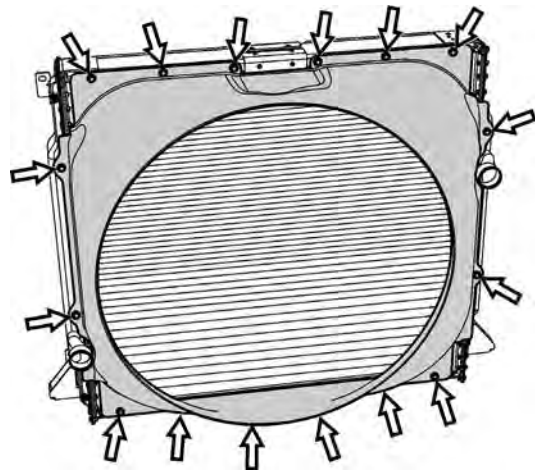

FIGURE 19

20. The new cooling pack arrangement requires being located **four inches** closer to the engine to give the needed clearance for the electric fans. For this reason, **rotate** both the radiator/CAC assembly **mounting supports 180°** and reinstall.

## BEFORE

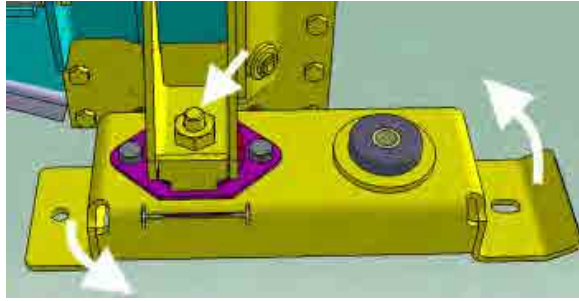

FIGURE 20: MOUNTING SUPPORT IN INITIAL POSITION

## AFTER

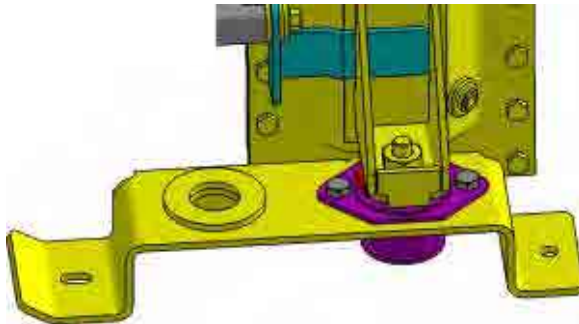

FIGURE 21: MOUNTING SUPPORT AFTER 180° ROTATION

21. Remove the **rear bumper** (undo three nuts and one attachment plate each side).

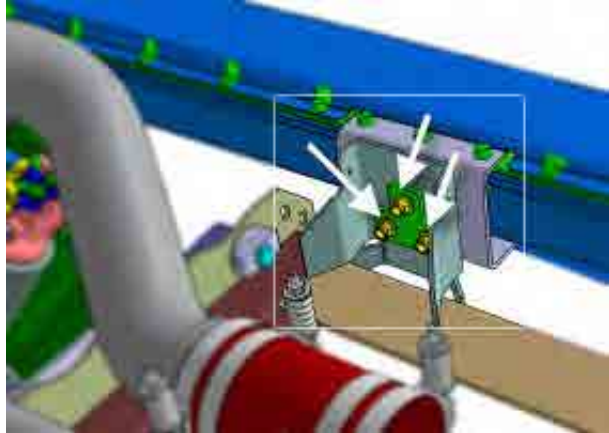

FIGURE 22

22. On the engine hot side, remove the following pipes:

- radiator inlet & outlet pipes
- CAC inlet and outlet pipes

**Keep the hose clamps, the flexible hoses for later reuse**

**Keep the fittings found on the pump inlet pipe for later reuse**

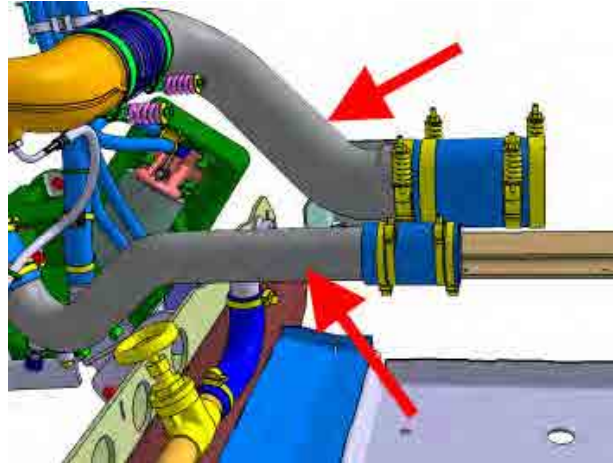

FIGURE 23

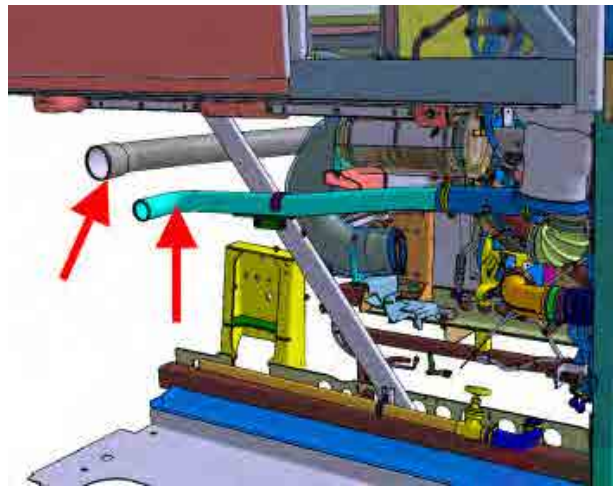

FIGURE 24

23. Remove all the drive belts mounted on the crank pulley.

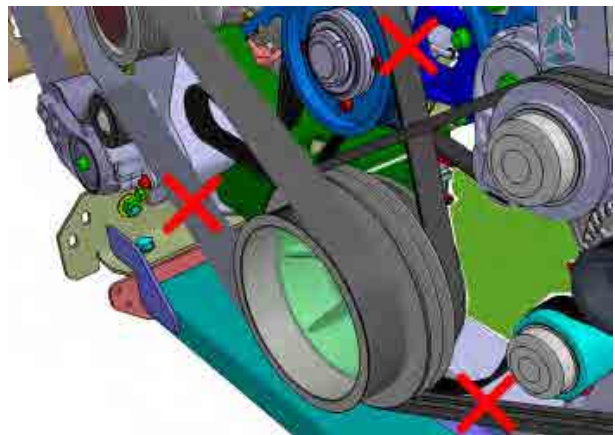

FIGURE 25

24. Remove the drive pulley. Discard the 6 bolts.

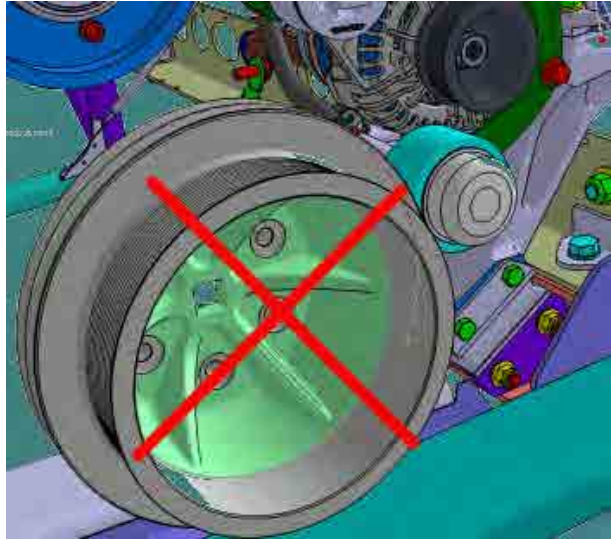

FIGURE 26

25. Remove the rust, clean and prepare the surface on the vibration damper as shown. Make a smooth surface for the pulley that will be reinstalled later on.



FIGURE 27



FIGURE 28

26. Properly support the engine as one of the engine support will be interchanged.



FIGURE 29

27. Remove the two (2) coolant hoses shown on the image. Keep the two (2) banjo fittings for later use.

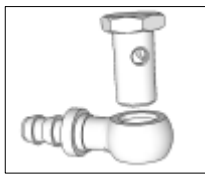

BANJO FITTING

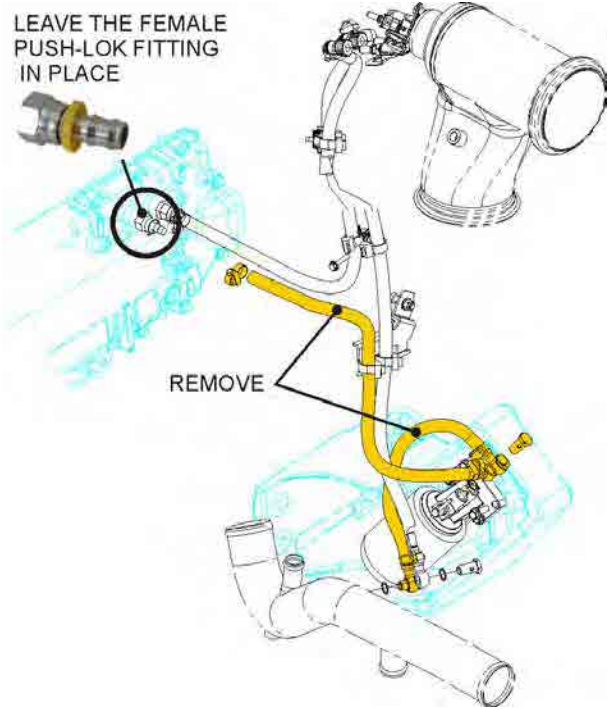

FIGURE 30

28. Remove the L.H. rear engine support on which the coolant filter is installed (10 bolts). Keep the hardware for reuse.

***Take note that the water pump belt idler/tensioner assemble will be reused as is. Do not take apart tensioner or idler.***

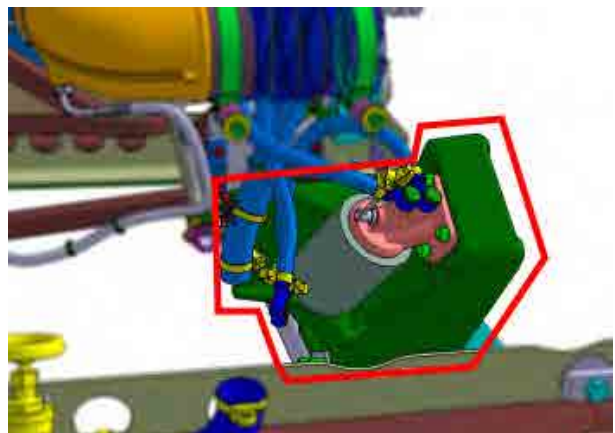

FIGURE 31: L.H. REAR ENGINE SUPPORT

29. Cut the engine cradle rail as shown to increase the clearance between the cradle and the alternator. Carefully work the edge to achieve a smooth finish and contour.

Wear appropriate personal protection equipment.

Protect engine and area with blankets.

Blow area clean when completed.

***Apply paint to protect the bare metal***

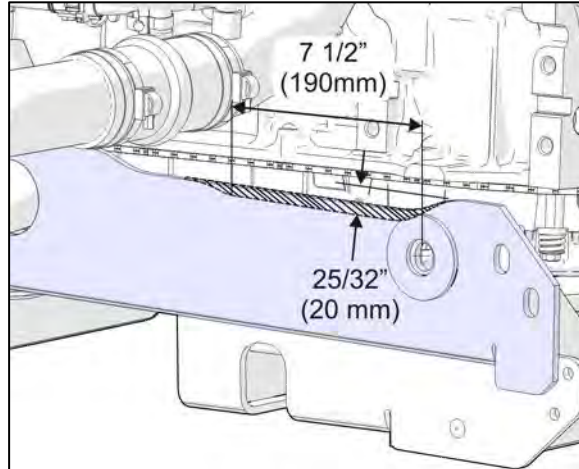

FIGURE 32

30. Remove the water pump idler/tensioner assembly from the former engine mount. To do so, unscrew three (3) bolts from the back of the engine mount.

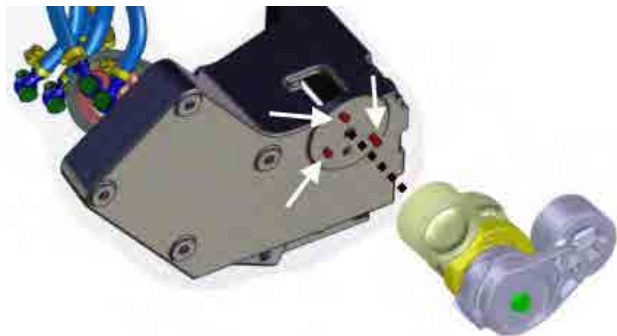
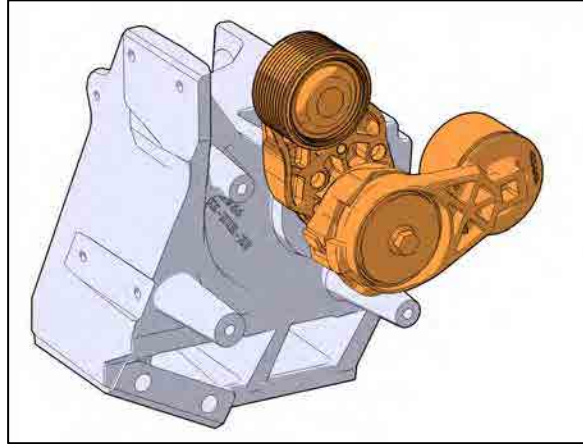

FIGURE 33

31. Reinstall the idler/tensioner assembly as a unit on the new L.H. engine mount #010090.

***Mount the idler/tensioner assembly using three (3) cap screws #5001643***

***Tighten to 14-17 lb-ft***



**FIGURE 34**

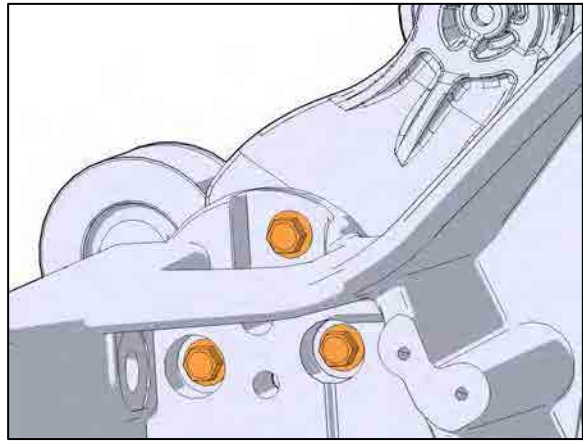

**FIGURE 35**

32. Install the new engine mount #10090 using seven (7) M14 screws saved from the former engine support with the exception of:

- Ground stud #012921 (1x) and nylon insert NYRT nut #5001665 (1X)
- Isolator cap screw #5001940 (2X)
- Nut #5001761 (2X)

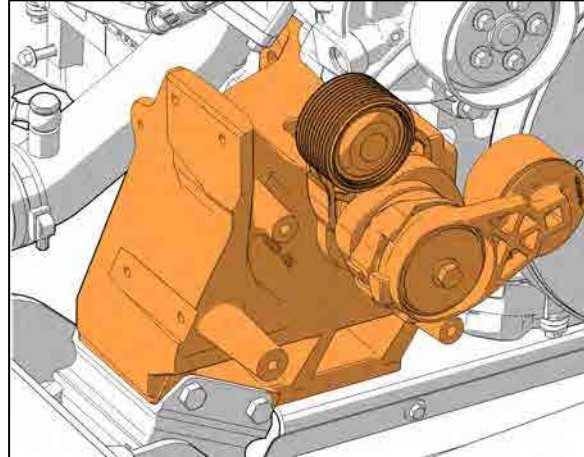

**FIGURE 36**

**Seven (7) mounting screws torque : 90-94 lb-ft  
(128 Nm)**

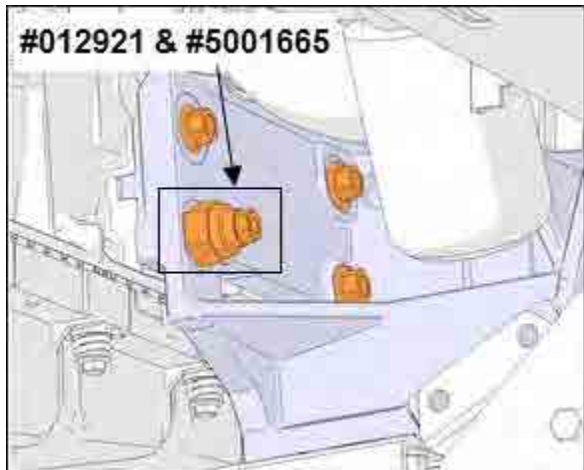

**FIGURE 37**

**Tighten ground stud to 94 lb-ft  
Tighten stud nut to 183 lb-ft**

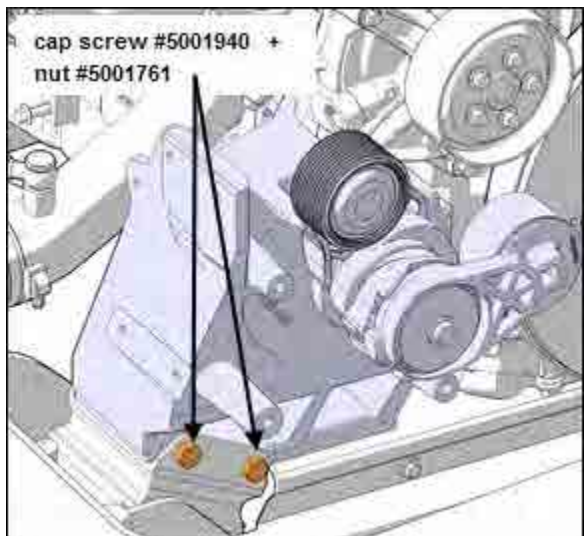

**FIGURE 38**

**Tighten isolator screws to 60 lb-ft**

33. Install the new crank pulley using six new bolts #5001296. Use blue Loctite on the bolt threads.

***Torque to 36 lbf-ft in a star pattern. Once done perform a final tightening to the value of 66 lbf-ft***

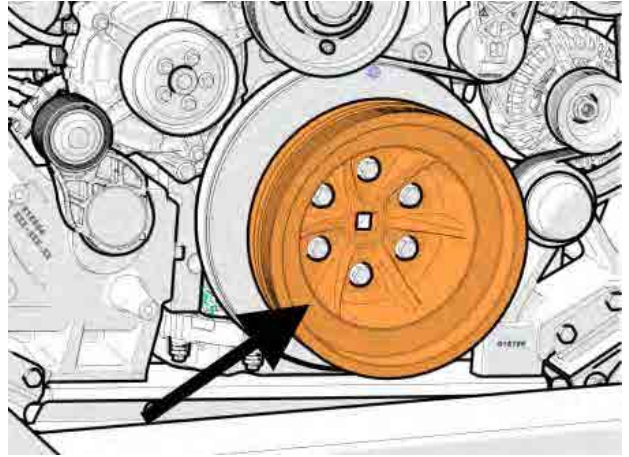

FIGURE 39

34. Reinstall the water pump drive belt.

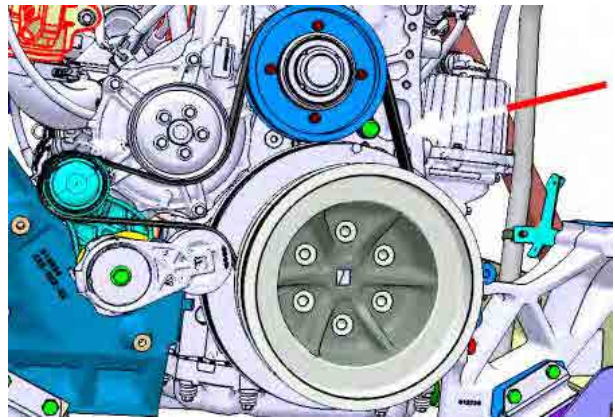

FIGURE 40: WATER PUMP DRIVEBELT

35. Reinstall the AC compressor drive belts.

36. Install **alternator brackets #069890 and #069891.**

**Note:** Install the upper bracket #069891 with short end towards bumper and long end towards turbo.

Use:

**4x cap screws #5001308**

Apply blue Loctite

Tighten to **48 lb-ft**

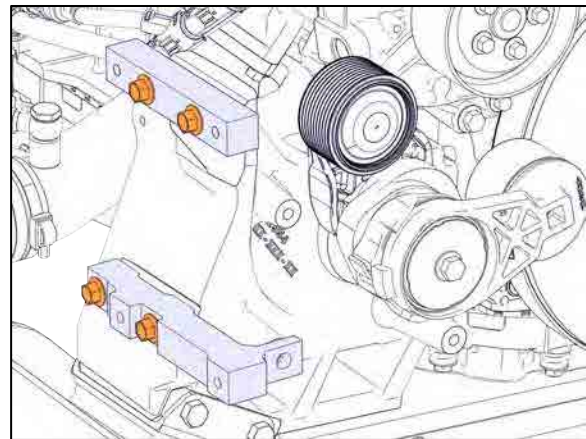

FIGURE 41

37. Installing the LH alternator pulley. Place #560720 alternator flat on a bench with the shaft horizontal.

Required tools:

- 15-16" crowfoot adapter
- 8mm hex bit

Clean shaft and pulley with brake cleaner.

Slide pulley #069893 on shaft by hand.

Hand thread nut on shaft until snug.

Using thin wall 15/16" adapter and 8mm hex bit to block shaft rotation, tighten to **70-80 lbf-ft**.

Never use power tools to install pulley and nut.

**Note:** Do not apply any pressure to end of the shaft. Internal damage may occur if the shaft is pushed back and turned.

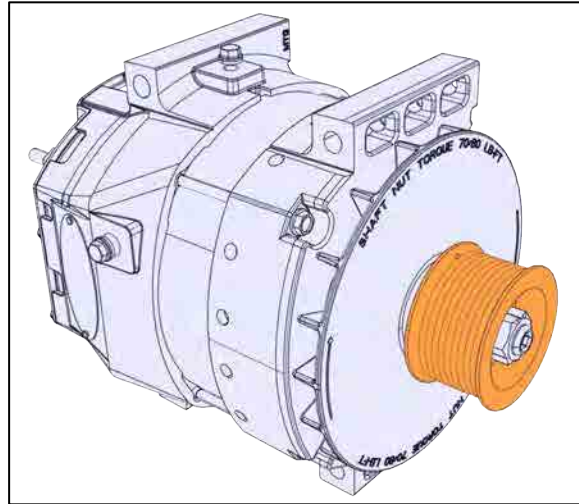

FIGURE 42

38. Install alternator on support with four (4) #5002091 M10x120 screws.

**Apply blue Loctite 680038**

**Tighten to 48 lb-ft**

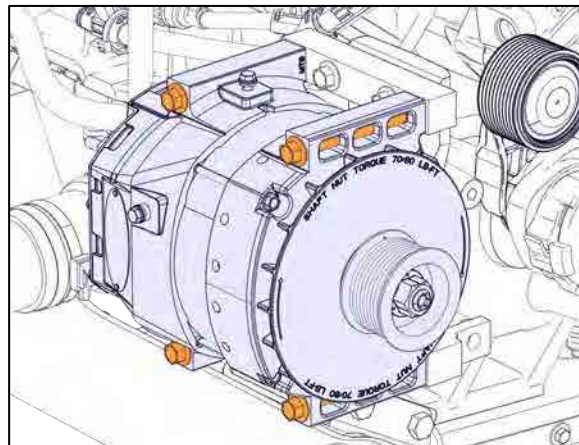

FIGURE 43

39. Install the idler support #012943 using:

**3x screws #5001799**

**Tighten to 48 lb-ft**

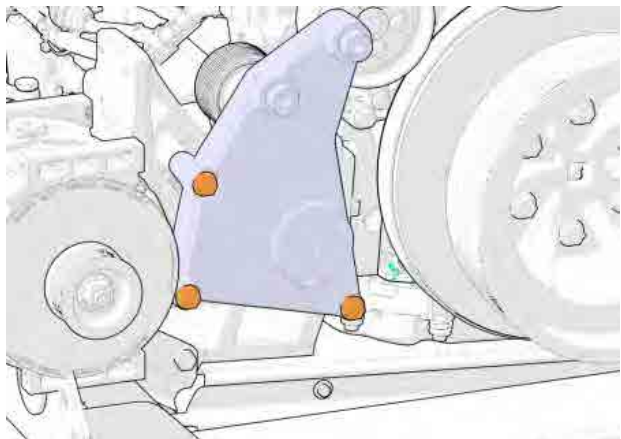

FIGURE 44

40. Install the new **idler #012349** with screw #5001786 and washer #5002008.

***Tighten to 82 lb-ft***



**FIGURE 45**

41. Install the dust cap #453076.

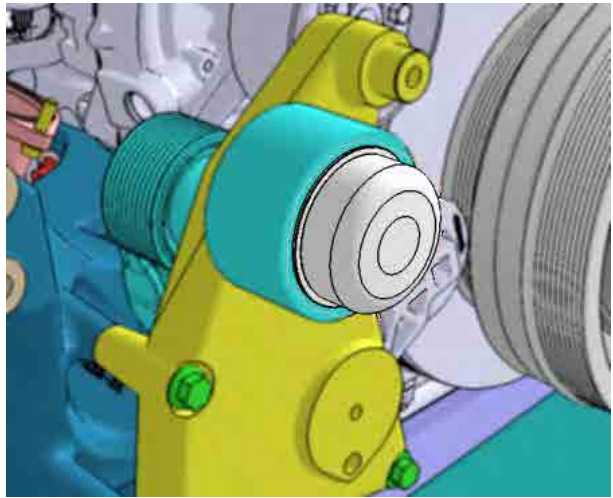

**FIGURE 46**



**FIGURE 47**

42. Install the new alternator tensioner #510991. Secure with one **screw #5001799** on which **blue Loctite** is applied.

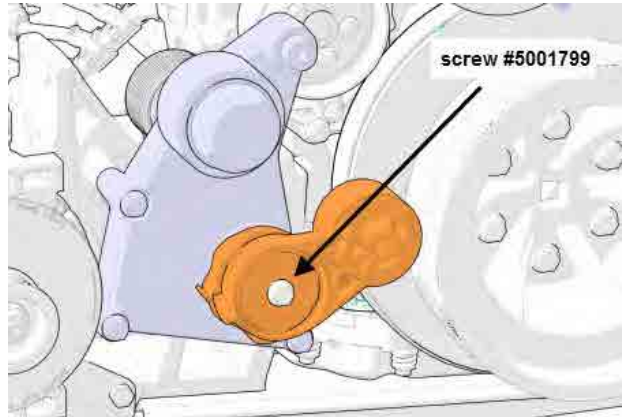

FIGURE 48: Tensioner mounting screw torque : 48 lb-ft

43. Install **belt #506067**. To do so, rotate the automatic belt tensioner using a ½ square drive breaker bar.

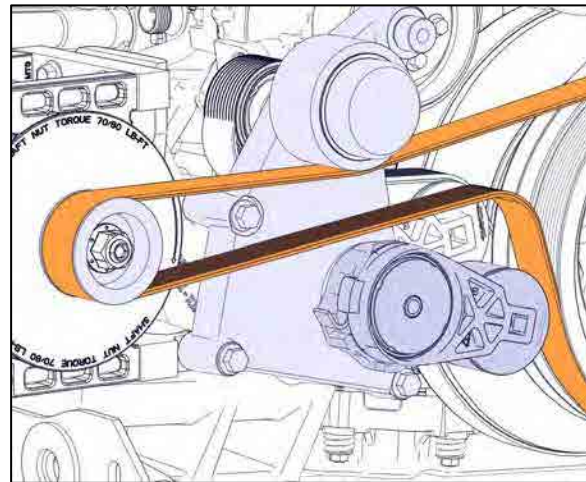

FIGURE 49

44. Remove former belt routing decal and replace with **decal #010111**.



FIGURE 50

45. Install control harness #0610037 on alternator.

Connect circuit **I** to Indicator (I) post.

Connect circuit **S** to Sense (S) post.

Use the following hardware:

- **2x nylon lock nut #5001180**
- **2x washer #5001137**

Tighten to the following torque values:

Sense (S): 25-45 lb-in

Indicator (I): 25-45 lb-in

Apply Color Guard rubber coating on connections.

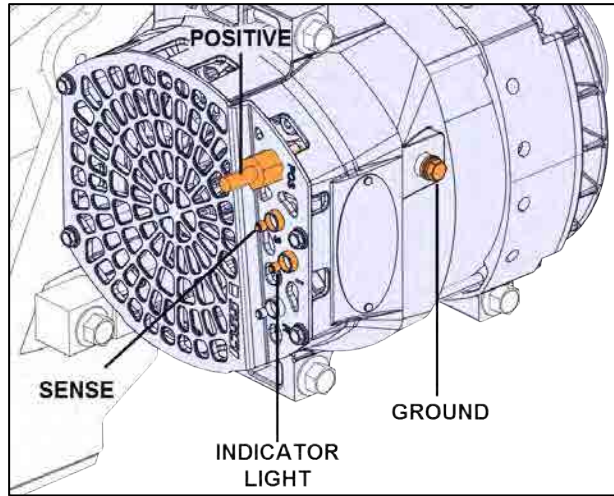

FIGURE 51

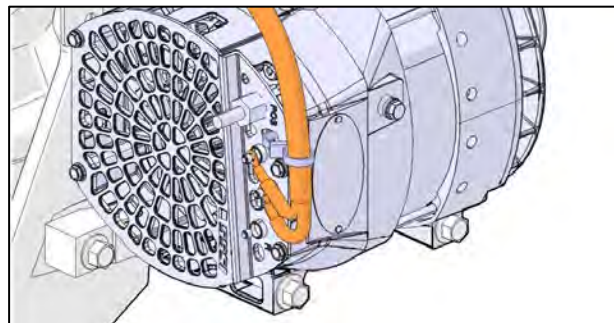

FIGURE 52

46. Weld the new coolant filter support #050265 on the engine cradle.

*24 inches from the end of the cradle*

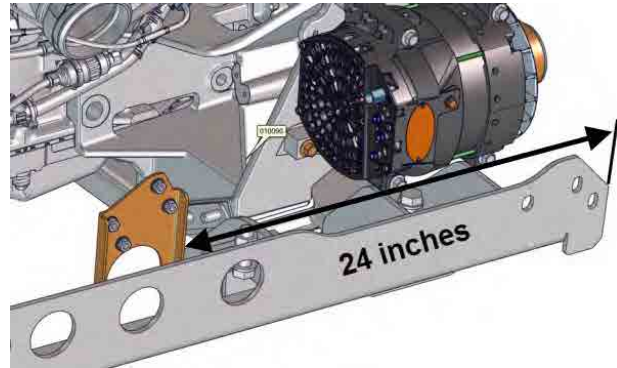

FIGURE 53

*3 inches above the flat surface of the cradle*

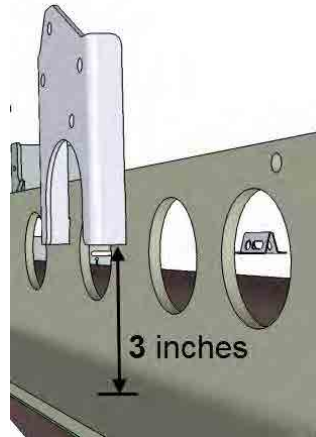

FIGURE 54

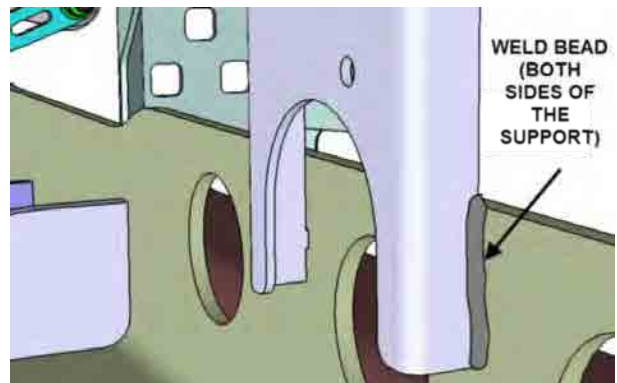
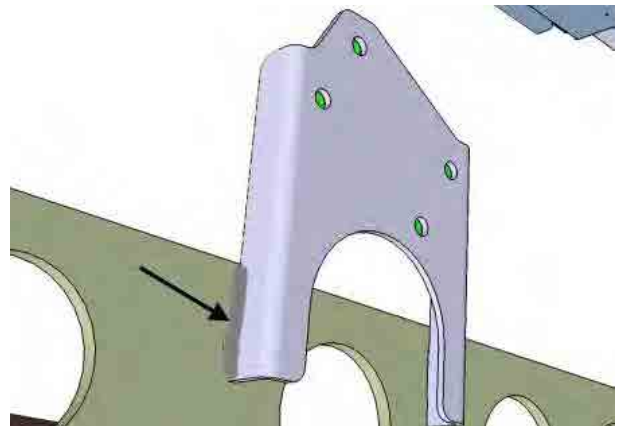

FIGURE 55



47. As a preparation to **welding**, buff the paint to reach bare metal. Weld the **ground stud #380360** centered in the beam and at 14 inches from the beam end.

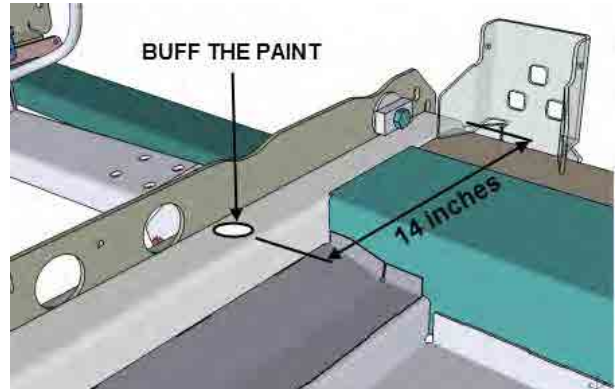

FIGURE 56



FIGURE 57: GROUND STUD #380360

48. Apply black paint to the area surrounding the ground stud and also on the ground stud circular base. **DO NOT** apply paint on the electrical contact surfaces.



FIGURE 58: GROUND STUD #380360

49. Install a tie mount #504013 with one screw #502686 at the back of the L.H. engine mount.



FIGURE 59

50. Install the alternator ground cable #0610035. Add a washer #500411 and then secure the cable lug with the alternator ground screw.



**torque: 50-60 lbf-in**

51. Secure the alternator ground cable to the previously installed tie mount using one (1) nylon tie #509491.

FIGURE 60

52. Secure the alternator ground cable to the previously installed ground stud on the L.H. engine mount.

**Use screw #502719 & washer #5001935**

**Tighten to 20 lbf-ft**

**Protection against corrosion. Apply Color Guard rubber coating on the ground stud once the ground cable is hooked up.**

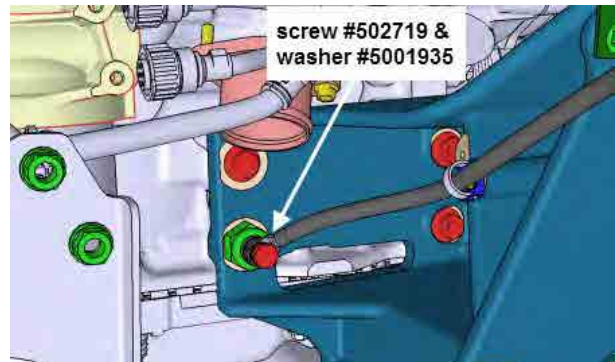

FIGURE 61

53. To the previously installed coolant filter support, install the filter holder recovered from the former installation.

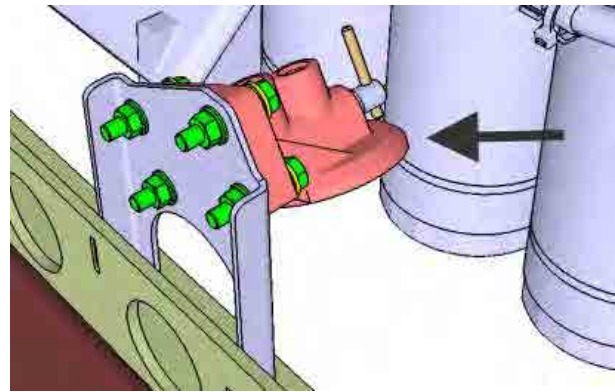

FIGURE 62

54. Install the new coolant filter onto the filter holder. Check the clearance between the filter and the close hose clamps of the coolant pipe leading to the transmission oil cooler.

FIGURE 63

55. Transfer the drain plug and the coolant extractor quick connect fitting saved from the old pump inlet pipe.

**Apply Loctite 567 Thread Sealant prior installation of the fittings**

56. Install the new radiator outlet pipe #050288. Reinstall with the flexible hose #053617 and the four (4) hose clamps #992089. Use steel wire to hold the end of the pipe until the radiator is installed if required.

**A: # 992089 hose clamp (4x)torque: 30 lbf-in**

**B: drain plug**

**C: coolant extractor quick connect valve**

**D: # 053617 silicone hose**

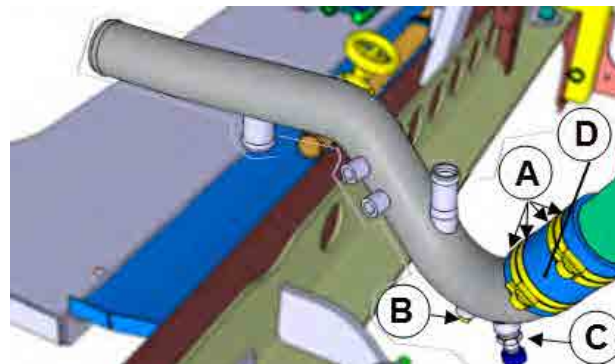

FIGURE 64

57. Reinstall the elbow between the copper heater line and the new radiator outlet pipe.

**For proper clamp torque, refer to HOSE CLAMP TORQUE on page 12.**

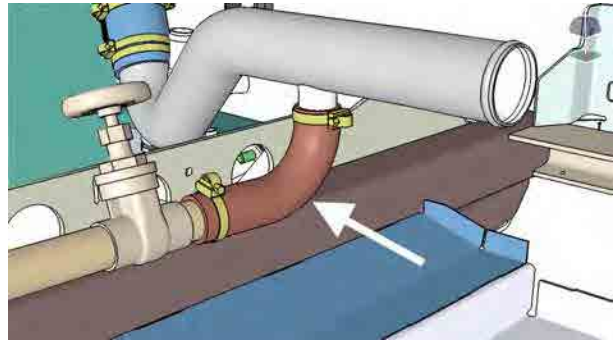

FIGURE 65

58. Using blue flexible hose #052366, prepare two new short hoses for the coolant filter.

a) Cut two sections of blue flexible hose, one **22 inches** long and a second **38 inches** long.

**A : hose clamp #992081 (4x)**

**B: banjo fitting copper washer #507657 (6x)**

b) Use the banjo fittings **recovered** from the previous installation.

**hose clamp torque: 30 lbf-in**

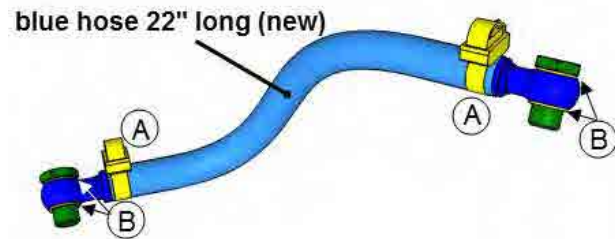

FIGURE 66

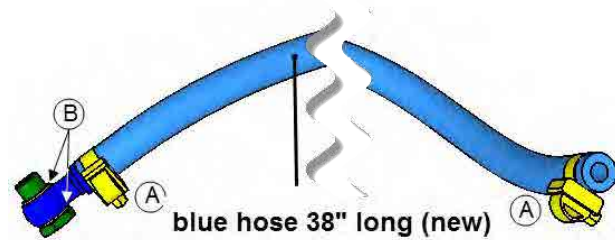

FIGURE 67

59. Install the 20" long and 36" long hoses prepared at the previous step as shown on the images.

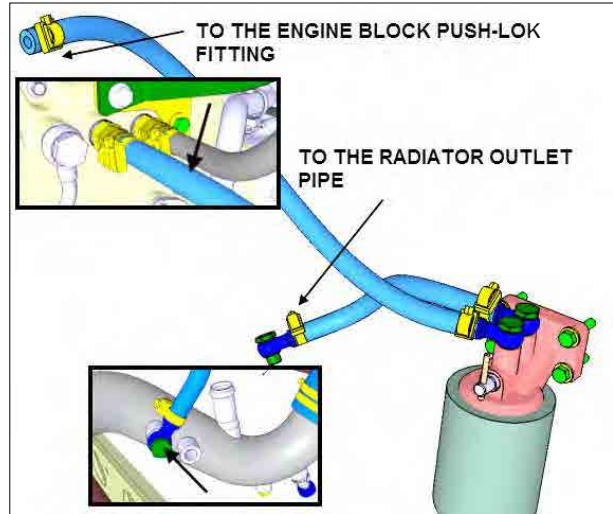

FIGURE 68



FIGURE 69

60. Connect the DEF injector coolant line return hose to the radiator outlet pipe.

**Use two (2) new banjo fitting copper washer #507657**

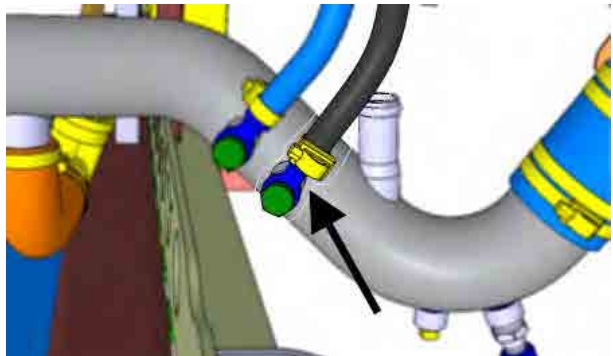
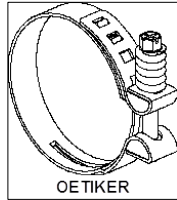

FIGURE 70: DEF INJECTOR COOLANT LINE RETURN HOSE

61. Connect the coolant line coming from the surge tank to the radiator outlet pipe.



CONSTANT TORQUE



OETIKER



CAILLAU

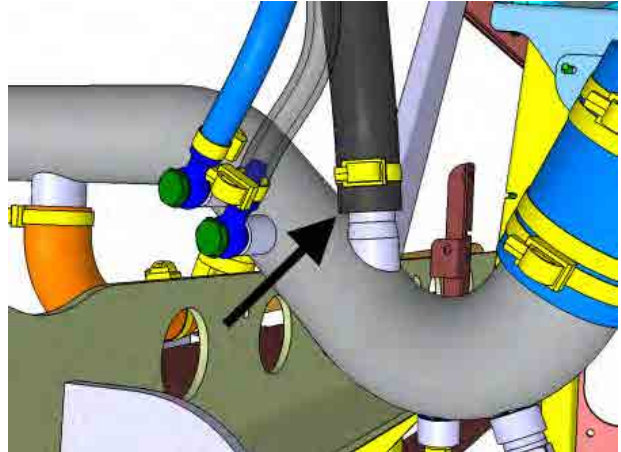

FIGURE 71

**TORQUES:**

**Constant-Torque with spring washers clamps : 90-100 lbf-in**

**Oetiker clamps – green spring : 12-18 lbf-in**

**Oetiker clamps – unpainted spring : 8-9 lbf-in**

**Caillau clamps : 30 lbf-in**

62. Secure the coolant hoses together using nylon ties.

**A : handcuff nylon tie #N37749 (3x)**



FIGURE 72

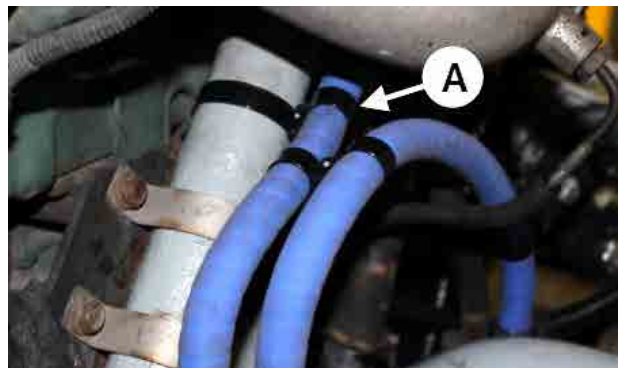

FIGURE 73

63. Secure the coolant hose near the engine block «push-lok» fitting as shown.

**B : nylon tie #504016 (1x)**

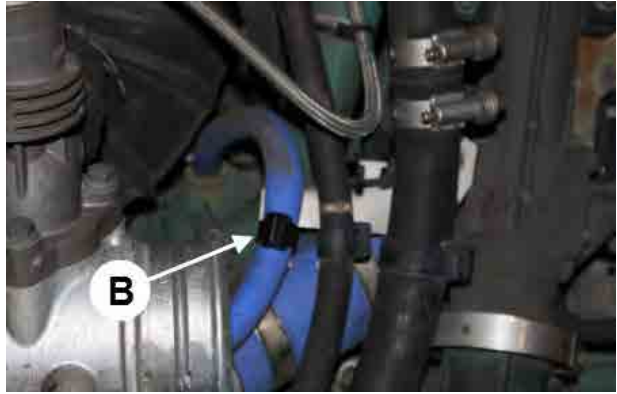

FIGURE 74

64. Hook up the “L.H. alternator power cable” #234524934 to the alternator positive (+) post.

**1x nut #500685 torque: 80-125 lbf-in**

**1x flat washer #5001341**

Apply Color Guard rubber coating at the alternator ground (⚡) and positive (+) connections.

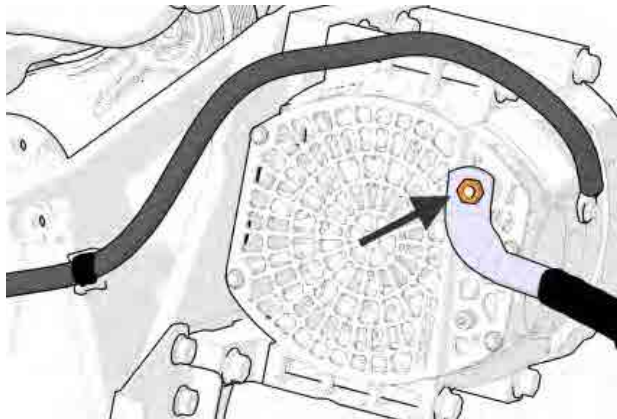

FIGURE 75

65. Connect the "fan drive ground cable" #069246 to the ground stud previously welded to the chassis.

**A:** split lock washer #500482

**B:** brass nut #500998

**C:** fan drive ground cable #069246

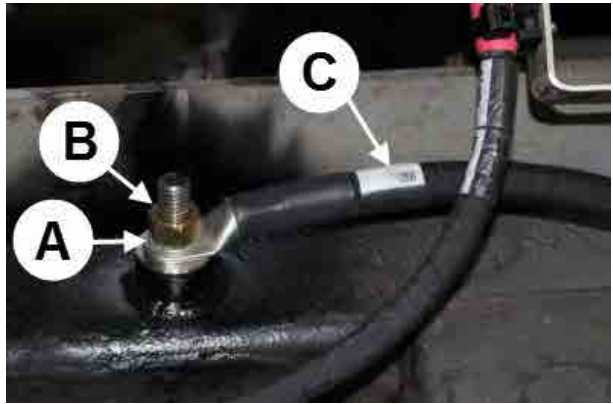

FIGURE 76



FIGURE 77

66. Apply Color Guard rubber coating on the ground stud connection.



FIGURE 78: GROUND STUD WITH RUBBER COATING

67. Install a tie mount #509490 at the location shown on the picture. Secure the tie mount with a rivet.

**A:** tie mount #509490

**B:** rivet #504610

**C:** nylon tie #509491

**D:** fan drive power cable #23498721

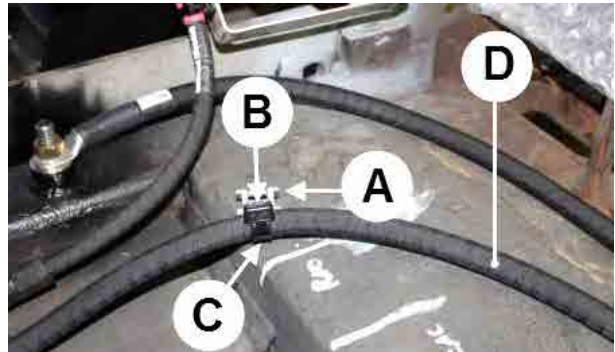

FIGURE 79

68. Secure the “fan drive power cable” #23498721 onto the tie mount using a nylon tie. Make sure to leave **26 inches long** from the tie mount up to the end of the “fan drive power cable” red connector.



FIGURE 80



FIGURE 81



FIGURE 82

69. Install **six (6) tie mounts** to secure the “fan drive power cable” and the “L.H. alternator power cable” as shown on the picture.

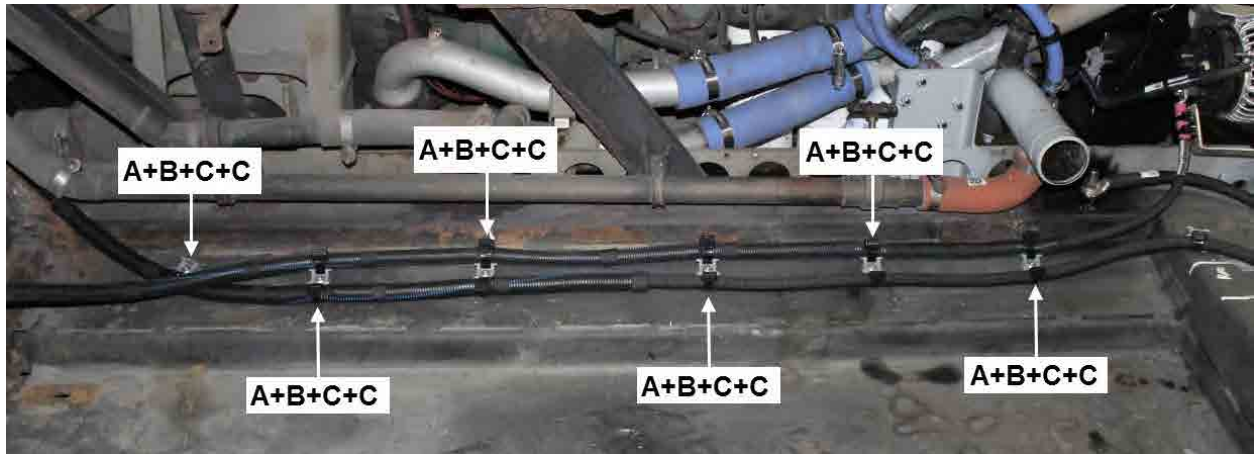

FIGURE 83

**A:** tie mount #509490

**B:** rivet #504610

**C:** nylon tie #509491



FIGURE 84

70. Route the “*fan drive power cable*” and the “*L.H. alternator power cable*” up to the main power compartment. Refer to the pictures at right as a guide for the installation.

71. Secure both cables using **seven (5) tie mounts #509490** fixed with **seven (5) rivets #504610**. Secure the cables on the tie mounts as previously done with **fourteen (10) nylon ties # 509491**.

**A:** tie mount #509490

**B:** rivet #504610

**C:** nylon tie #509491

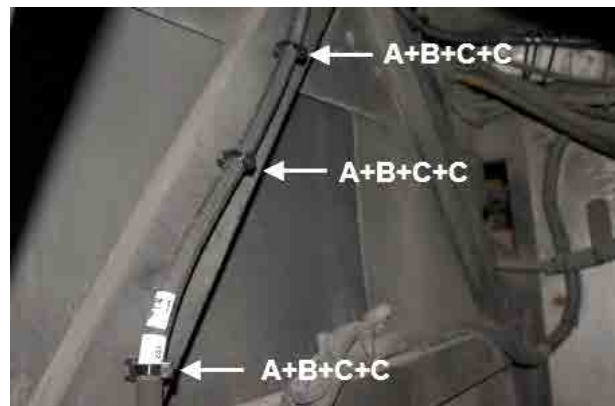
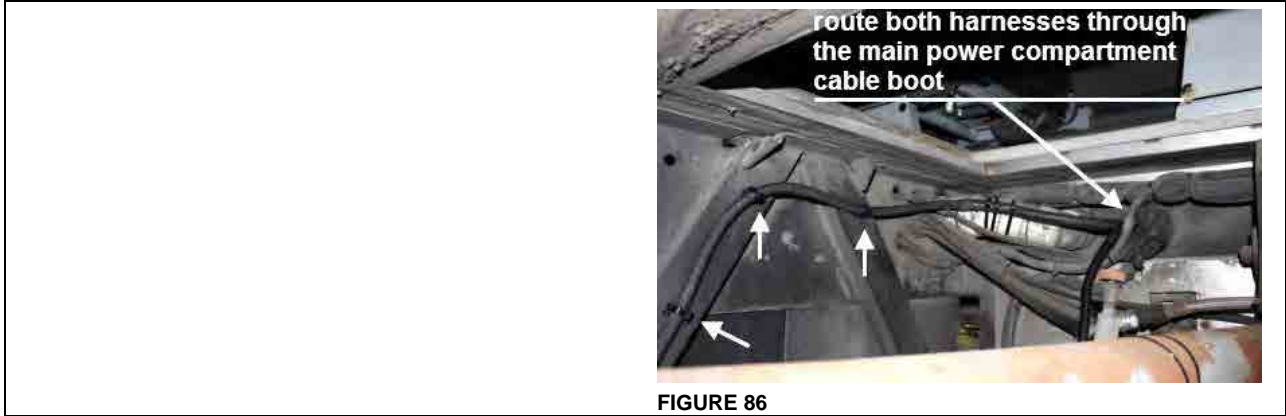
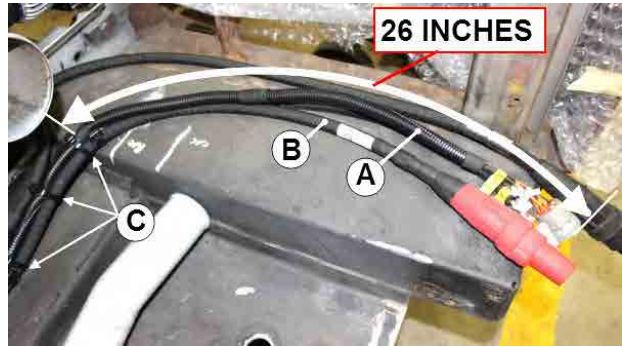

FIGURE 85



**72. INSTALLATION OF THE “FAN TO RJB INTERFACE” HARNESS #23488790**

- a) Route the “fan to RJB interface” harness #23488790 up to the main power compartment. Secure this harness to the fan drive power cable using nylon ties #504016.
- b) This harness will be connected close to the fan drive power cable, thus it also requires 26 inches of free length.



**FIGURE 87**  
**A: FAN TO RJB INTERFACE” HARNESS #23488790**  
**B: FAN DRIVE POWER CABLE**  
**C: NYLON TIES #504016 (23x approx.)**

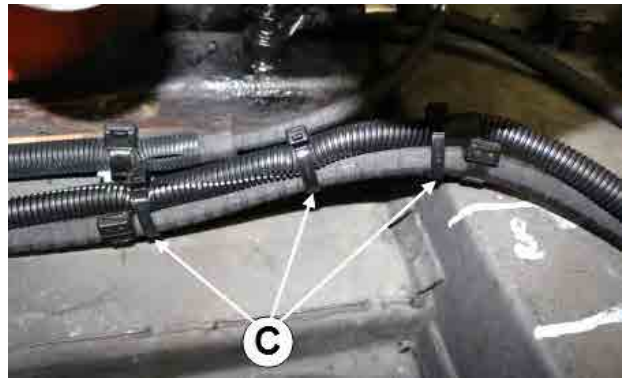

**FIGURE 88**

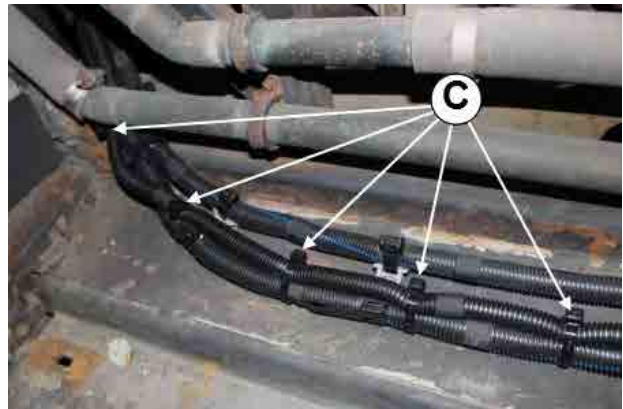

**FIGURE 89**

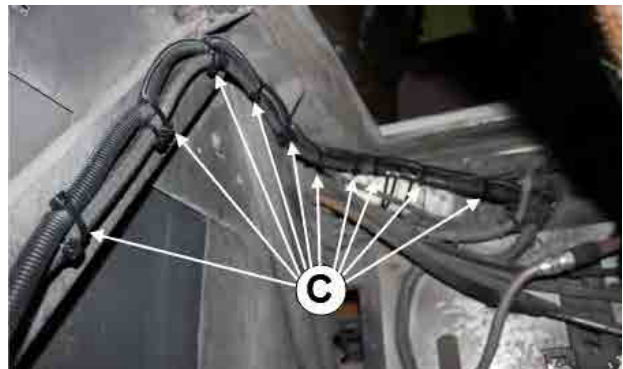

**FIGURE 90**

73. Connect the new CAC outlet pipe #050406 to the engine intake elbow.

**A: #20550690 hose (1x)**

**B: #21490630 spring loaded clamp (2X) (torque: 5 lbf-ft)**

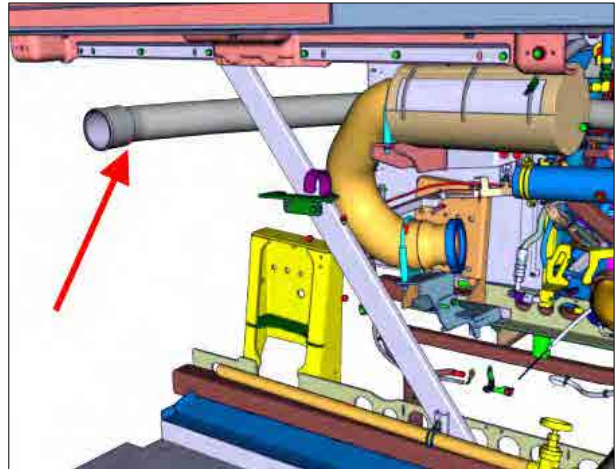

FIGURE 91

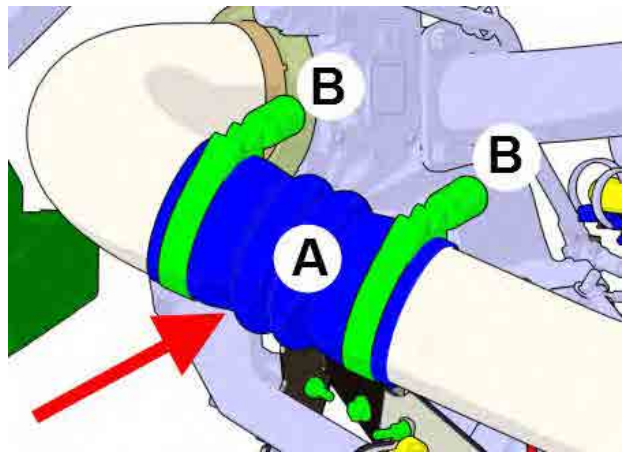

FIGURE 92: CONNECTION AT THE ENGINE INTAKE ELBOW

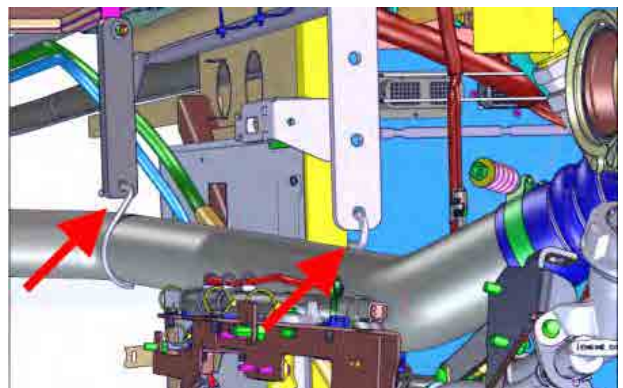

FIGURE 93

74. If your vehicle is equipped with AFSS (Automatic Fire Suppression System), the new CAC outlet pipe #050406 is likely to come into interference with a AFSS extinguishing agent hose (see image) near the end of the pipe that connects with the Charge Air Cooler.

If this is the case, move the hose the other side of the bracket shown, to prevent rubbing between the hose and the CAC outlet pipe.

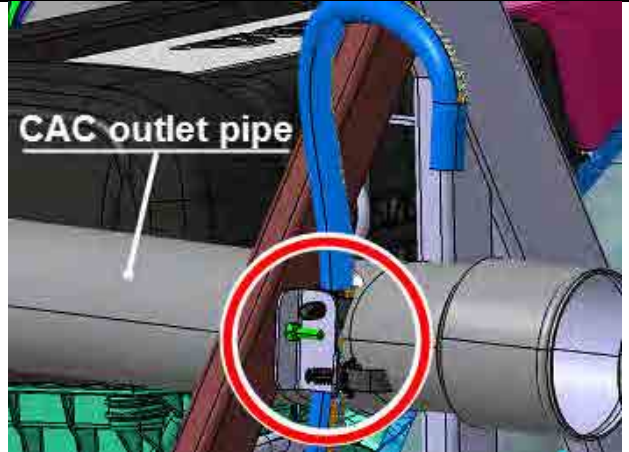

FIGURE 94

75. On the diagonal member, change the existing radiator inlet pipe bracket for the new one #050305. Use the existing hardware.

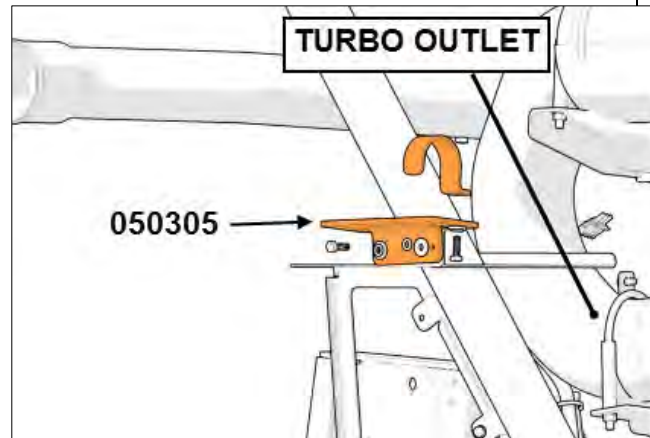

FIGURE 95

76. Install the new radiator inlet pipe #050414.

**A: #052889 silicone hose**

**B: # 992089 hose clamp (4x), torque: 30 lbf-in**

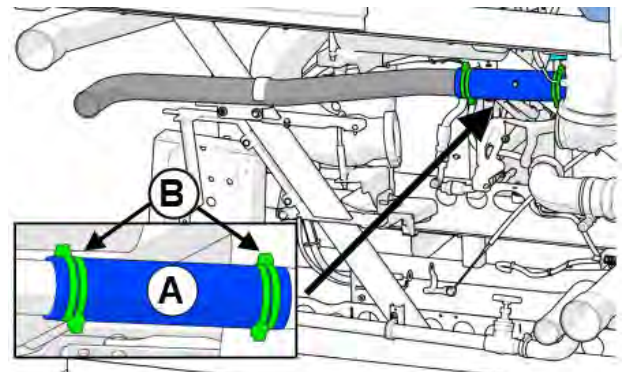
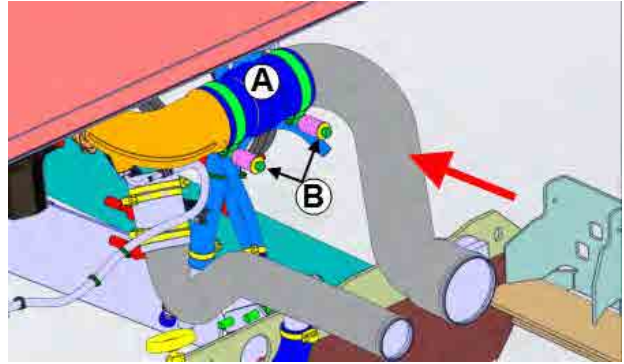

FIGURE 96

77. Install the new **CAC inlet pipe #050286**. Use one new **#20550690 CAC flexible hose**. Secure the hose using two (2) spring loaded clamps **#21490630**.

**A: #20550690 hose**

**B: #21490630 spring loaded clamp (2X), torque: 5 lbf-ft**



**FIGURE 97: CONNECTION AT THE TURBO OUTLET ELBOW**

78. Reinstall the cooling pack.

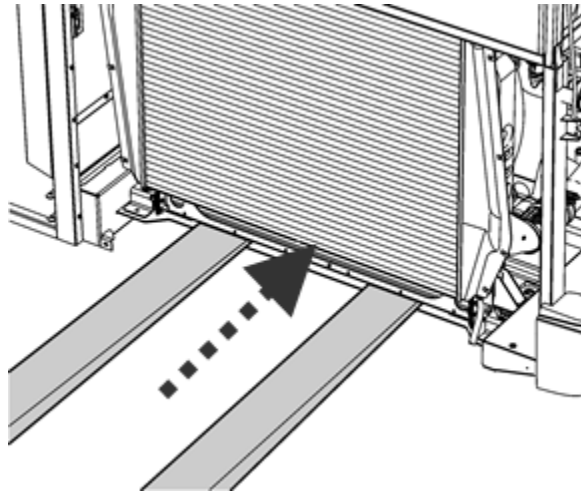

**FIGURE 98**

79. Secure the cooling pack base with the following parts:

**A: 4x screw #502804**

**B: 8x washer #5001751**

**C: 4x nut #502859**

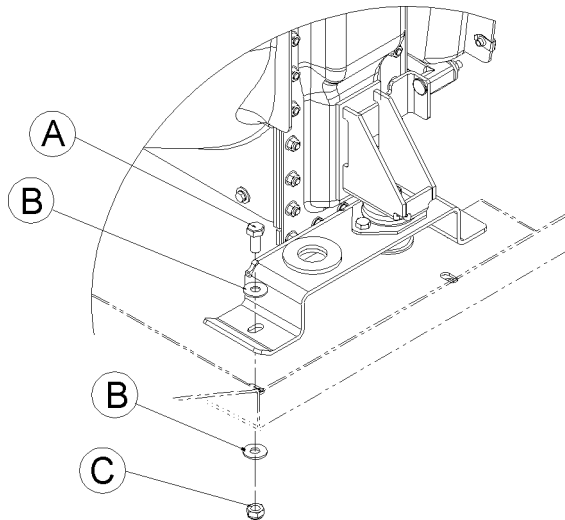

**FIGURE 99**

80. Using parts #501332, #501308, #501329, #501027, mount the brass fitting assembly shown on the image at right.

**Apply Loctite 567 Thread Sealant on the threads**

**A: #501027**

**B: #501329**

**C: #501308**

**D: #501332**

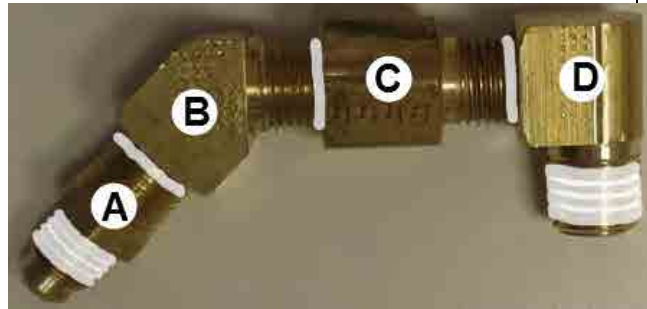

FIGURE 100: BRASS FITTING ASSEMBLY

81. Remove the vent hose fitting found on the radiator.

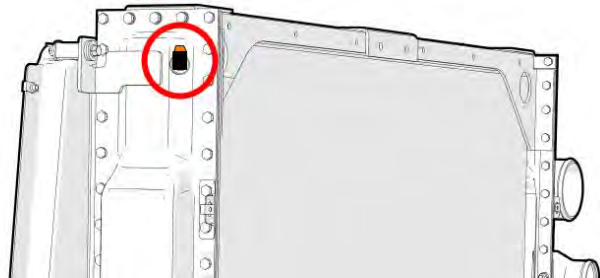

FIGURE 101

82. Install the brass fitting assembly in place of the former vent hose fitting and then connect the **radiator vent hose** to the radiator.



83. Prepare the **cooling pack upper attachment** with the three (3) rectangular plates (see image) recovered from the former installation and the following parts:

**A: anti-vibration mount #21185073**

**B: upper radiator support #050214**

**C: 2x screw #5001738 , 2x nut #502837**

**D: 2x screw #5001738 , 2x washer #500942**

**E: 2x screw #5001745 , 2x washer #500942**

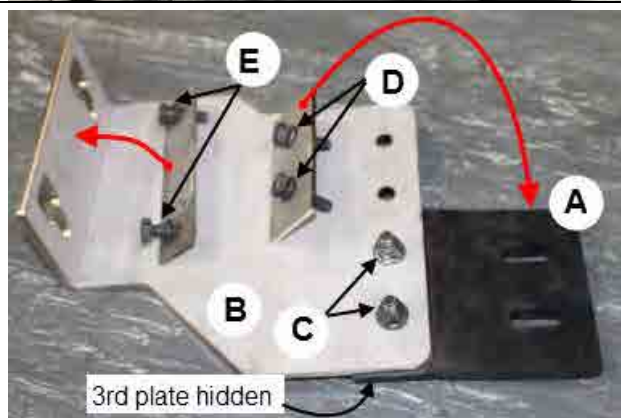

FIGURE 102

One end of the upper attachment is mounted on the radiator frame (image at right)

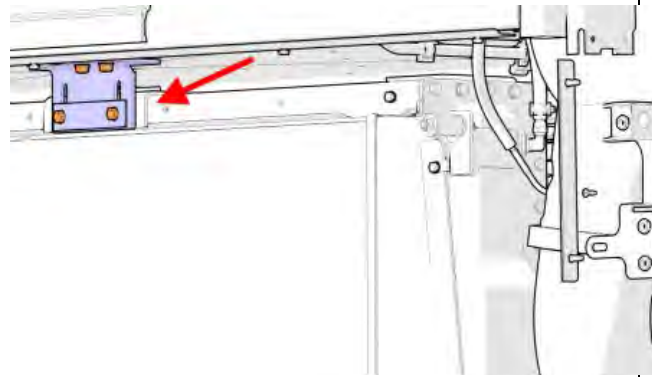

FIGURE 103

Bolt the anti-vibration mount onto the vehicle chassis

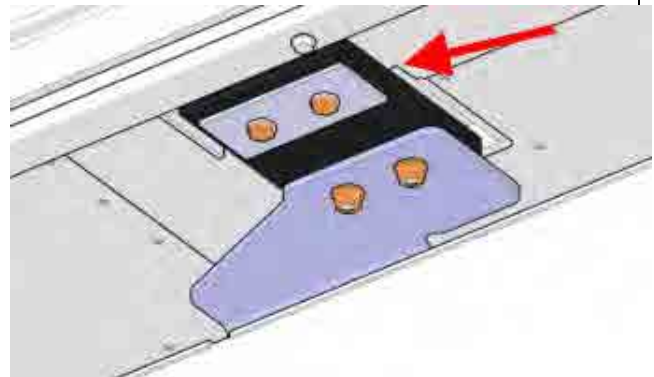

FIGURE 104

84. Reinstall all the blue flexible hoses at the CAC and radiator (at the lower connections of the cooling pack). Install with the following parts:

**A: #21490616 clamp (4x) (torque: 5 lbf-ft)**

**B: #531471 flexible hose**

**C: #053617 silicone hose**

**D: #992089 (4x)**

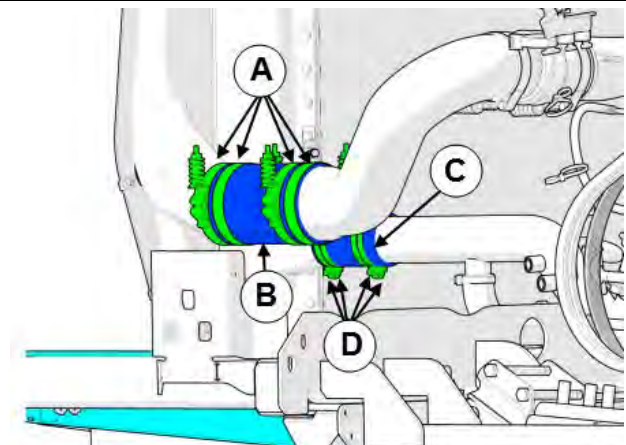

FIGURE 105

85. Reinstall all the blue flexible hoses at the CAC and radiator (at the upper connections of the cooling pack). Use the following parts::

**A: 1x flex hose #531469**

**B: 1x silicone hose #053617**

**C: 4x clamp #21490616 (torque: 5 lbf-ft)**

**D: 4x clamp #992089**

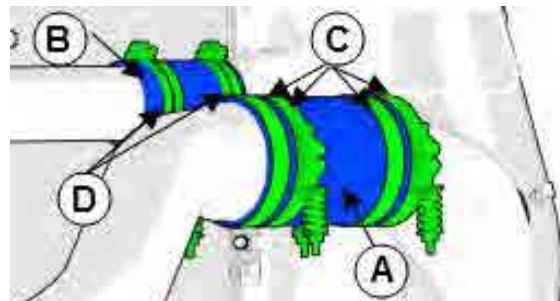

FIGURE 106

**For proper clamp torque, refer to HOSE CLAMP TORQUE on page 12**

86. Reinstall the lower cooling pack protector tube with the following hardware:

**4x Screw #502804**

**4x split lock washer #5001737**

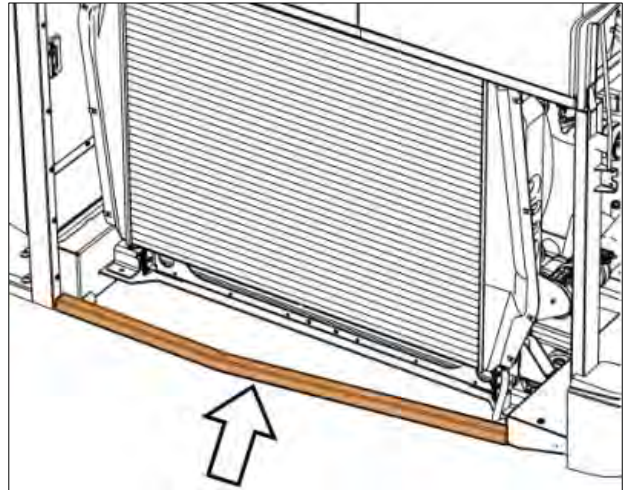

FIGURE 107

87. Install the sealing element #050200. Screw it on the existing threaded holes on the upper part of the radiator. Secure with the following hardware:

**6x bolt #5001697**

**6x lock washer #502570**

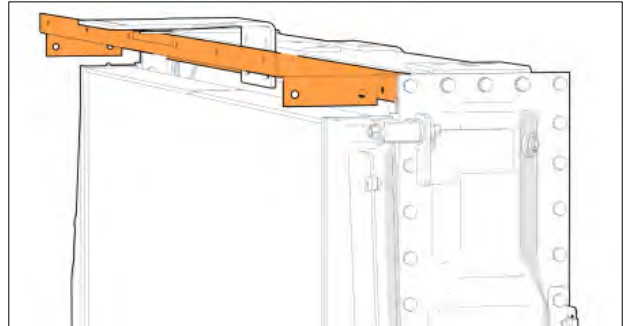

FIGURE 108

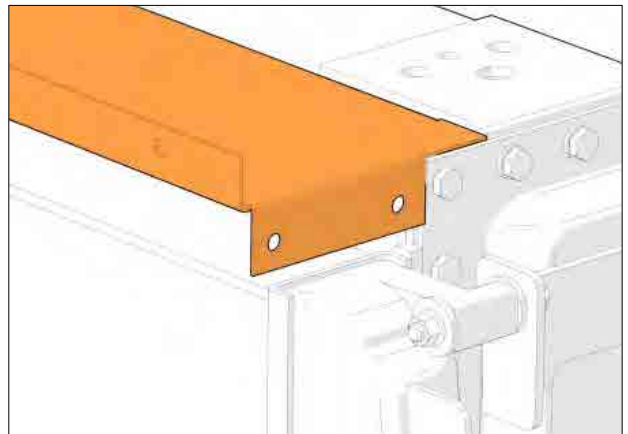

FIGURE 109

88. Install the sealing element #050203. Screw it on the existing threaded holes on the bottom of the radiator. Secure with the following hardware:

**6x bolt #5001697**

**6x lock washer #502570**

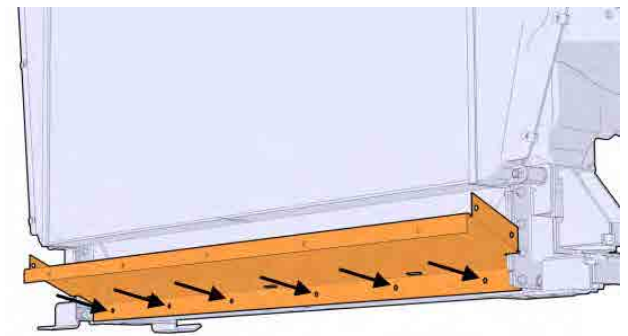

FIGURE 110

89. Prepare the sealing elements #050201 and #050202. On both parts, apply foam tape #506040 on the edges as shown on the image.

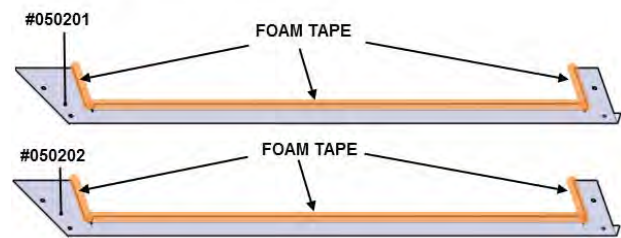

FIGURE 111

90. Install the sealing elements #050201 and #050202. Screw them onto the upper and lower sealing elements installed at the previous steps. Secure with the following hardware:

**8x bolt #5001697**

**8x lock washer #502570**

**A: #050201**

**B: #050202**

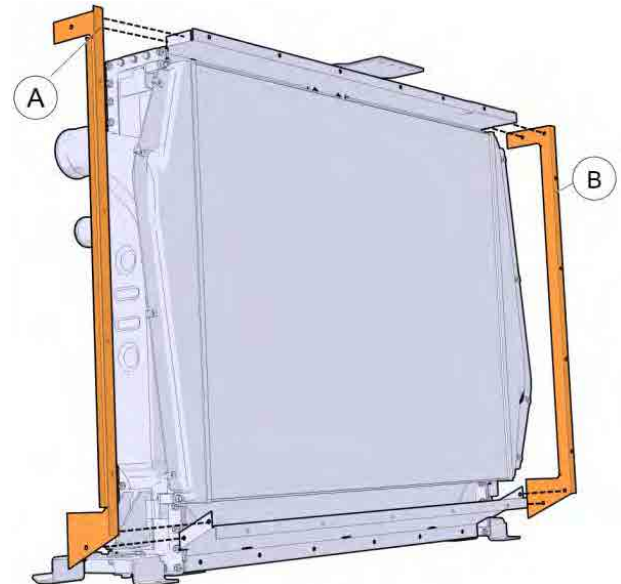

FIGURE 112

91. Cut two pieces of 39 inches (990 mm) long of **rubber extrusion #506025n**.
92. Using good industrial glue (Loctite 404 or similar product), glue the two pieces of rubber extrusion centered on the reinforcement angles of fan support panel #050195.



FIGURE 113

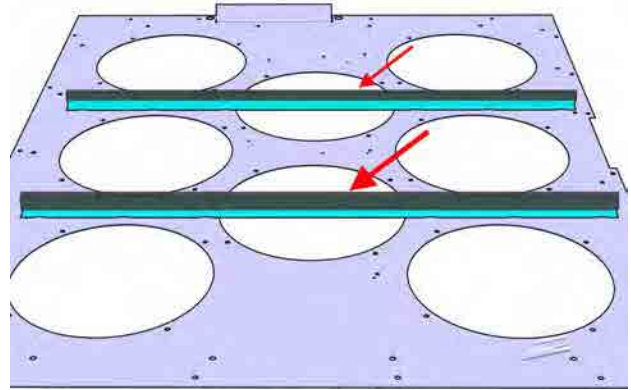

FIGURE 114

93. Install the fan support panel **#050195**.  
Secure with the following hardware:

**19x bolt #5001697**

**19x lock washer #502570**

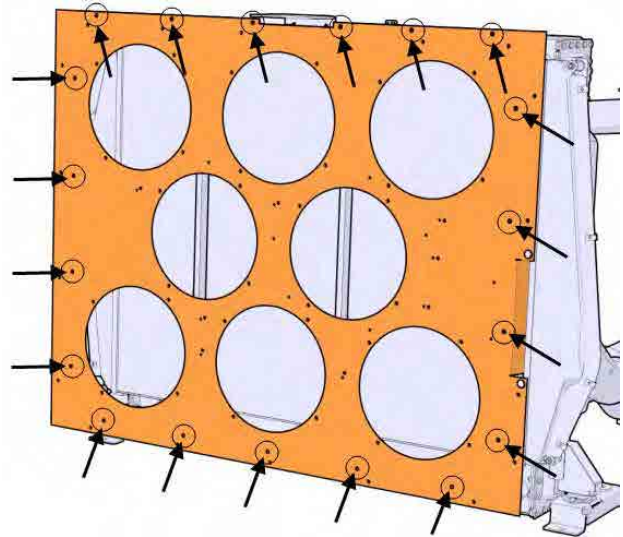

FIGURE 115

94. Install the upper left #050204 and upper right #050206 sealing elements.

Secure with the following hardware:

**6x bolt #5001697**

**6x lock washer #502570**

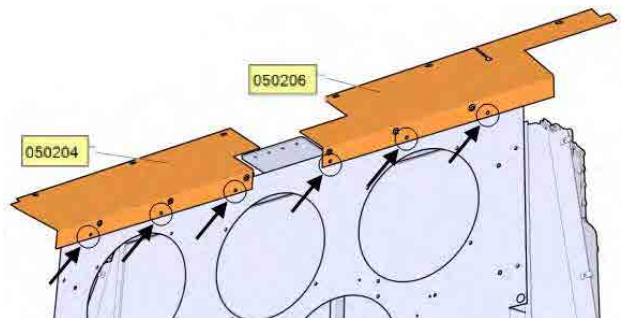

FIGURE 116

95. Install the lower sealing element #050213.

Secure with the following hardware:

**5x bolt #5001697**

**5x lock washer #502570**

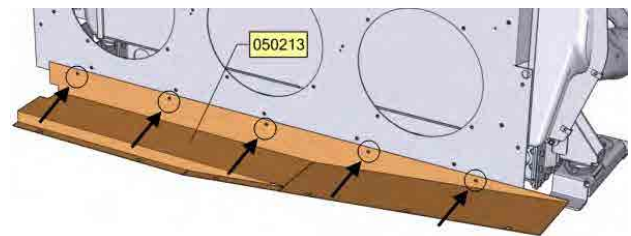

FIGURE 117

96. Install the L.H. side sealing element #050208.

Secure with the following hardware:

**4 bolts #5001697**

**4 lock washers #502570**

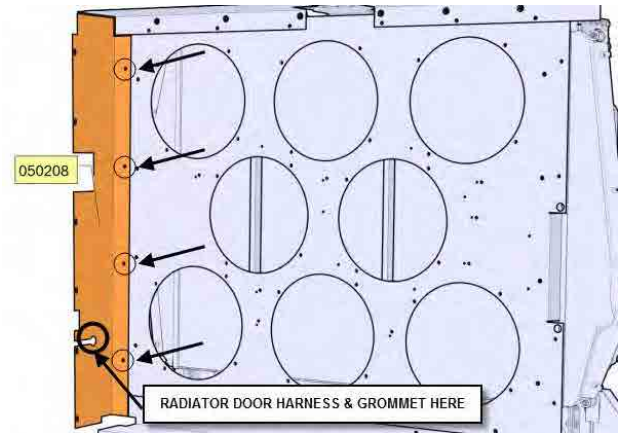

FIGURE 118

97. Install the R.H. side sealing element #050255.

Secure with the following hardware:

**4x bolt #5001697**

**4x lock washer #502570**

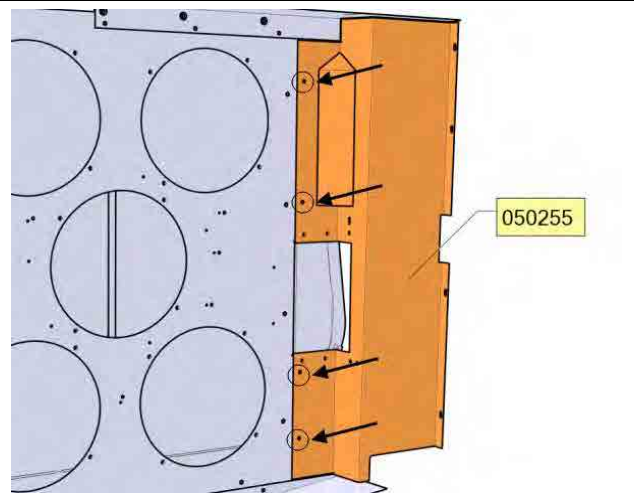

FIGURE 119

98. With a paint marker, identify the fans from 1 to 8 with the corresponding number found on a label on their respective blue connector.



99. Install the fans and **fan hand guards** on the panel in the same arrangement shown on the image. **Be sure to place the fan so that the cable is at the proper location, 3 O'clock, 6 O'clock or 12 O'clock.** Refer to the image at right.



FAN HAND GUARD

Install with the following hardware:

**32x bolts #502686**

**32x lock washers #5001833**

**Prescribed torque:30 lbf-in**

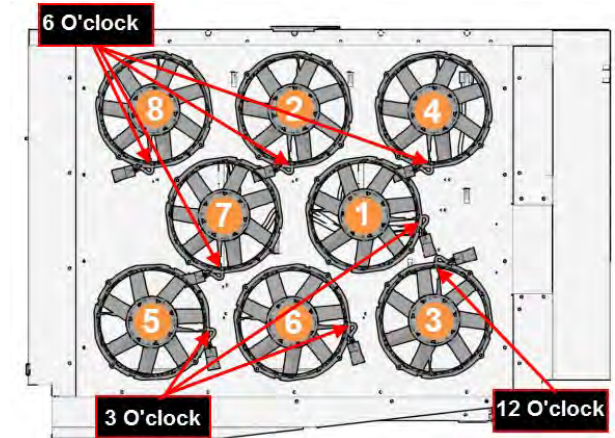

FIGURE 120

100. Snap the fan blue connector in the holes punches on the panel for that matter.

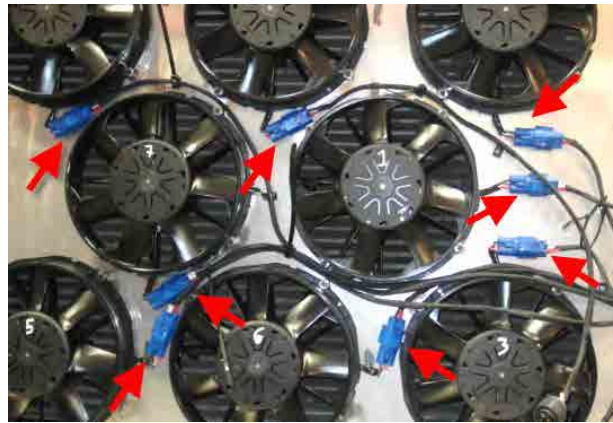

FIGURE 121

101. Route and secure the fan cables as shown on the images.

Secure with the following parts:

**A= nylon tie mount #504013 + rivet  
#504379 + nylon tie #504016**

**B= nylon tie #504016**

**Do not tighten the nylon ties at this moment**



FIGURE 122

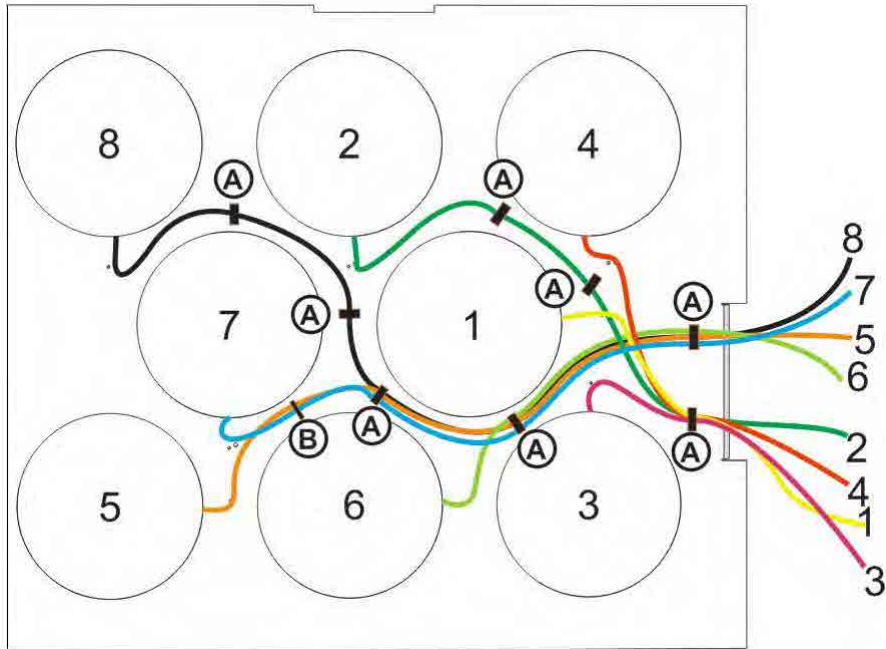

FIGURE 123

102. Install the circuit breaker box #564520.

Install with the following hardware:

**4x bolt #500119**

**4x lock washer #5001868**

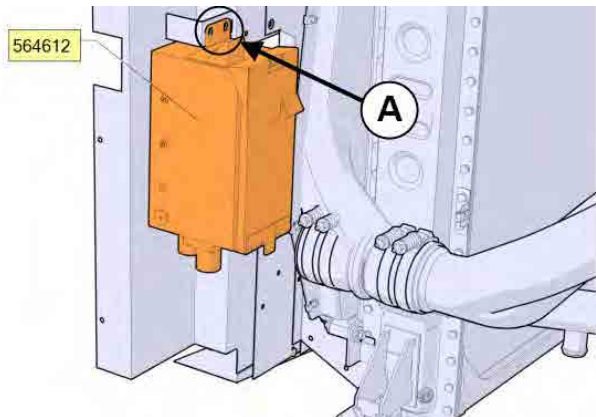

FIGURE 124

**A: 2x bolt #500119 + 2x lock washer #5001868**

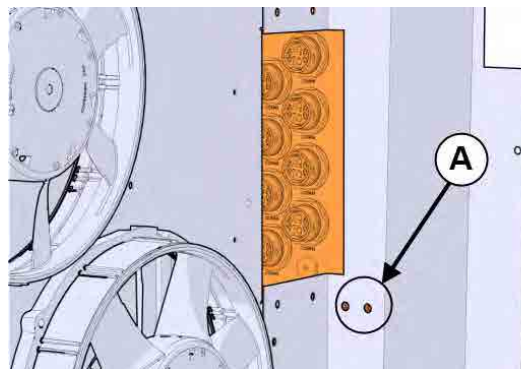

FIGURE 125

**A: 2x bolt #500119 + 2x lock washer #5001868**

103. Connect each fan to the corresponding connection port on the circuit breaker box.

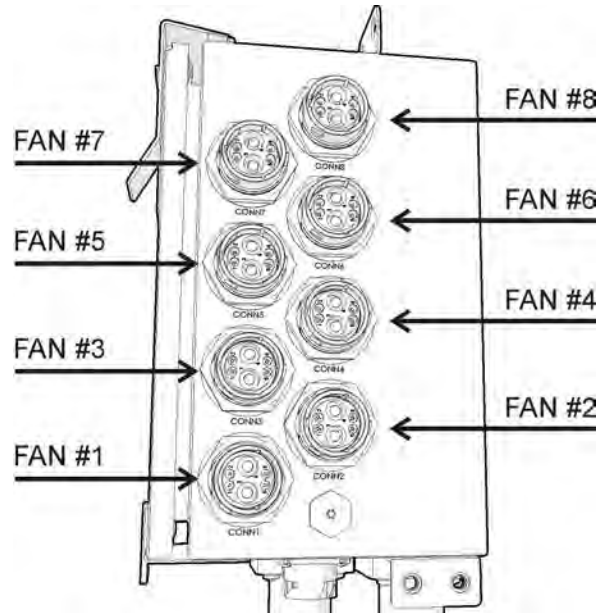

FIGURE 126

104. Tighten the nylon ties previously installed while routing the fan cables.
105. Use two (2) additional **nylon ties #504016** to secure the extra-length of cables together close to the circuit breaker box as shown on the image at right.

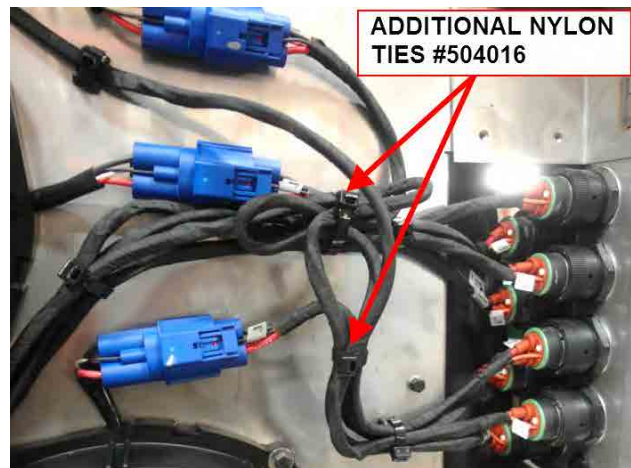

FIGURE 127

106. Install the electrical **connector cover # 050229**.

Fasten with the following hardware:

**4x bolt #5001697**

**4x lock washer #502570**

107. Using good industrial glue (Loctite 404 or similar product), glue three (3) pieces of rubber extrusion #506025 as shown on the connector cover.

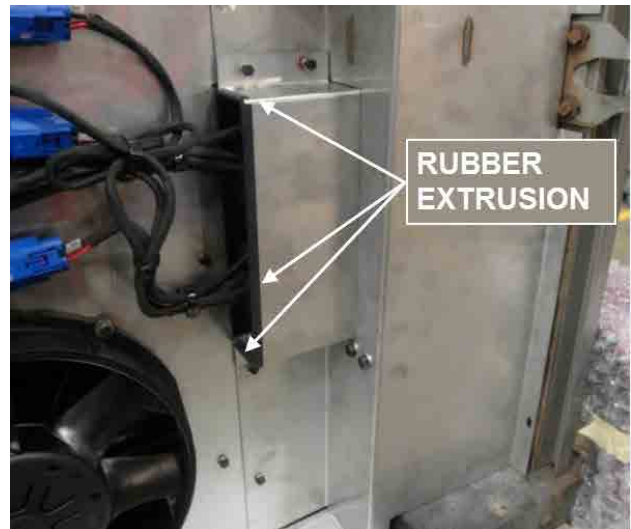

FIGURE 128



FIGURE 129

108. Complete the installation of the sealing elements. Screw the panels to the chassis threaded holes where shown on the image. Use the following hardware:

**22x bolt #502848**

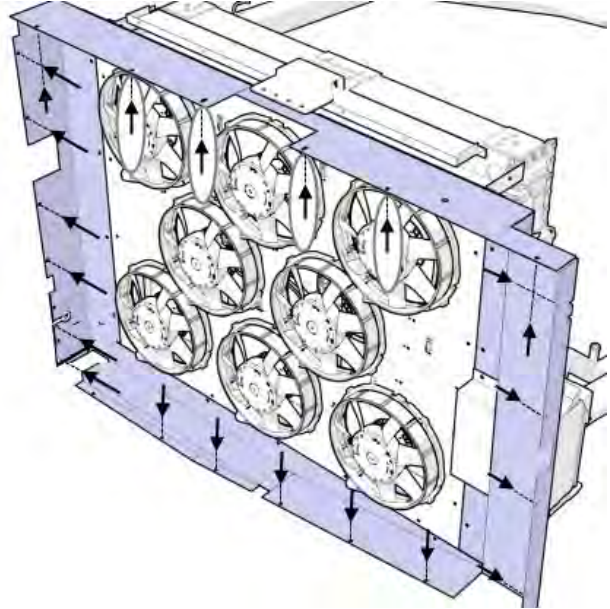

FIGURE 130

109. Complete the connection of the cables and harness to the fan circuit breakers box (three connectors: gray, black, red).

**A: fan drive ground cable (black connector)**

**B: fan drive power cable (red connector)**

**C: "fan to RJB interface" harness (gray connector)**

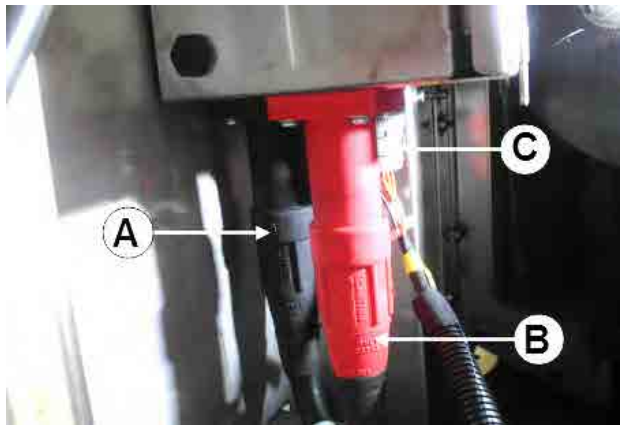

FIGURE 131

110. Secure the fan drive ground cable and the fan drive power cable connected to the fan drive circuit breakers box as shown on the pictures.

**A:** rivet #504379 (6x)

**B:** tie mount #504013 (6x)

**C:** nylon tie #504016 (6x)

**D:** handcuff nylon tie #N37749 (1x)

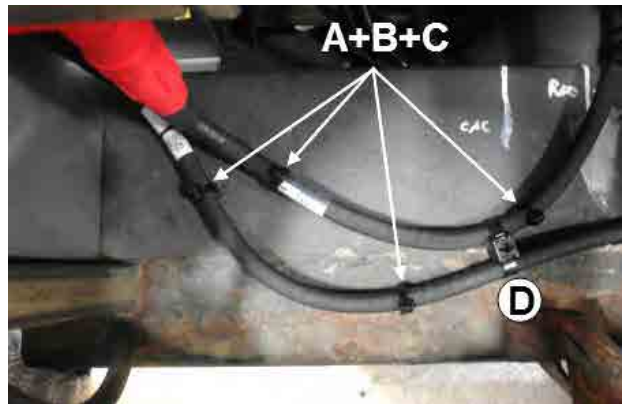

FIGURE 132

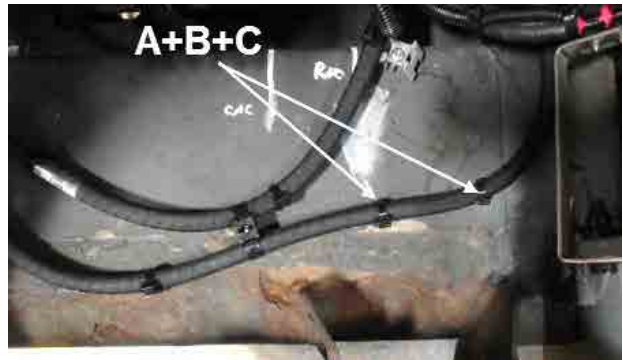

FIGURE 133

111. Connect the alternator control harness connector **C-ALT3** to connector **C-ALT3** of the "fan to RJB interface" harness. Secure the extra length of harness as shown with nylon ties.

**A:** handcuff nylon tie #N37749 (3x)

**B:** nylon tie #504016 (4x)

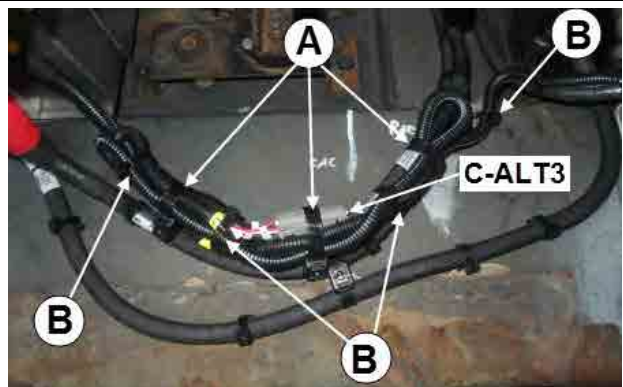

FIGURE 134



FIGURE 135

## INSTALLATION OF ELECTRIC COMPONENTS AND HARNESS CONNECTIONS IN THE MAIN POWER COMPARTMENT

### SCHEMATIC DIAGRAM OF ELECTRICAL CABLES & HARNESSES

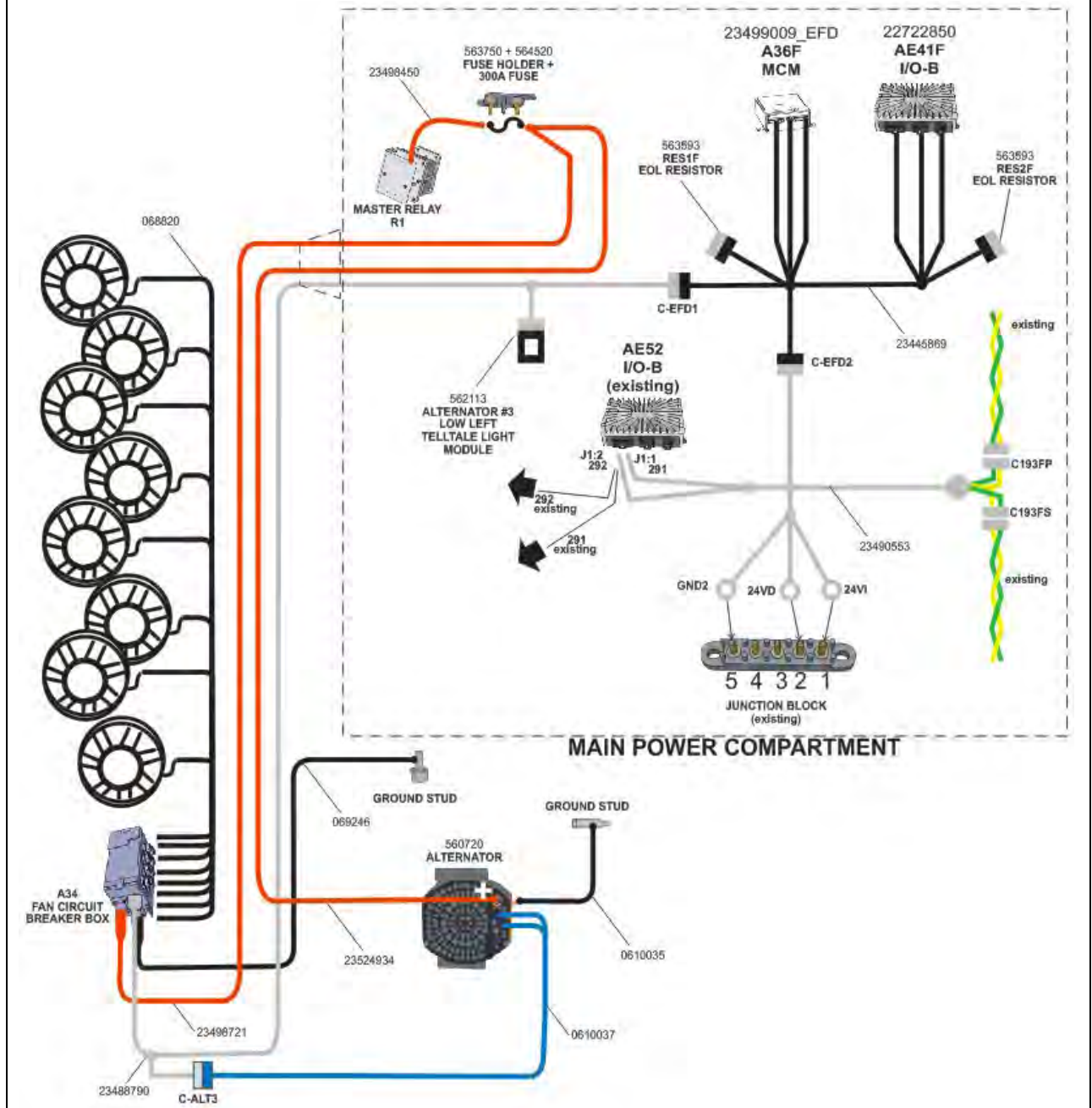

112. In the battery compartment, disconnect the battery ground cable from the chassis ground stud.

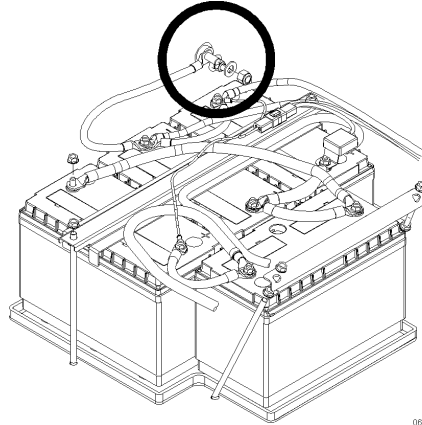

113. Most of the electric components will be installed on the bulkhead at the right of **master relay R1** (when facing it). Identify the master relay R1 on the image at right.

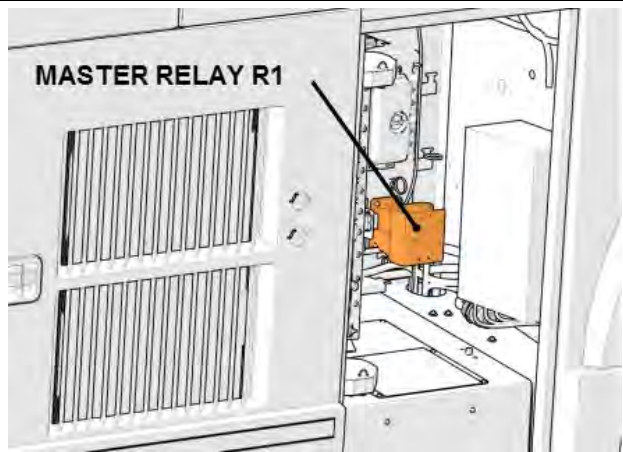

FIGURE 136

114. If the situation applies to the vehicle on which you are working on, remove the two (2) useless studs found on the bulkhead and then sand to leave a smooth surface.

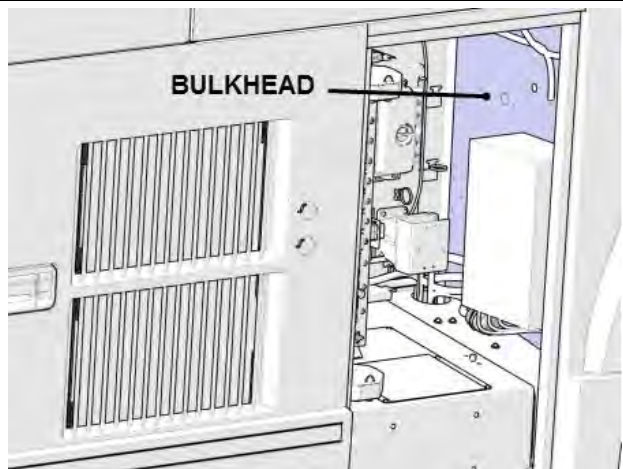

FIGURE 137



FIGURE 138

115. Make sure this is no voltage at the master relay R1 posts and then, remove the master relay R1 cover.

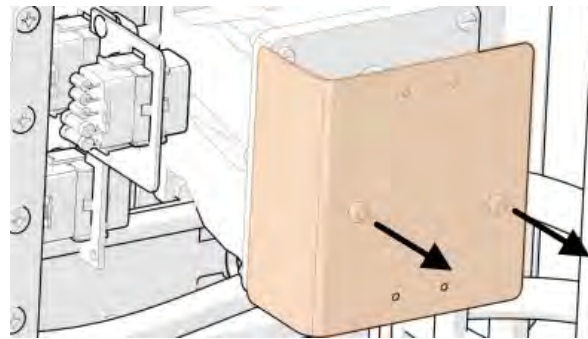

FIGURE 139

116. Disconnect the four (4) cable lugs connected to the master relay R1 upper post.
117. Momentarily, connect the elbowed lug of the "master relay R1 to 300A fuse" cable #23498450.

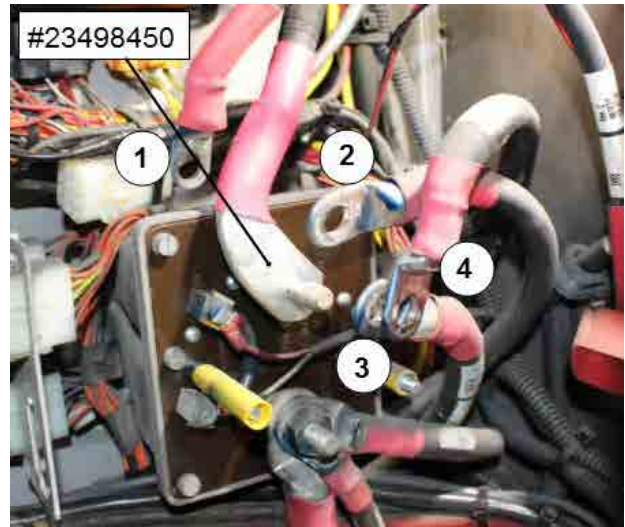

FIGURE 140

118. Find the best location where to install the **fuse holder #563750** on the bulkhead. Take note that the fuse holder must be installed at the distance that allows cable #23498450 to reach it.
119. Drill two 11/64 pilot holes for the installation of the fuse holder on the main power compartment bulkhead. Secure with the following hardware:  
**A: tapping screws #500658 (2x) + flat washer #5001341 (2x)**

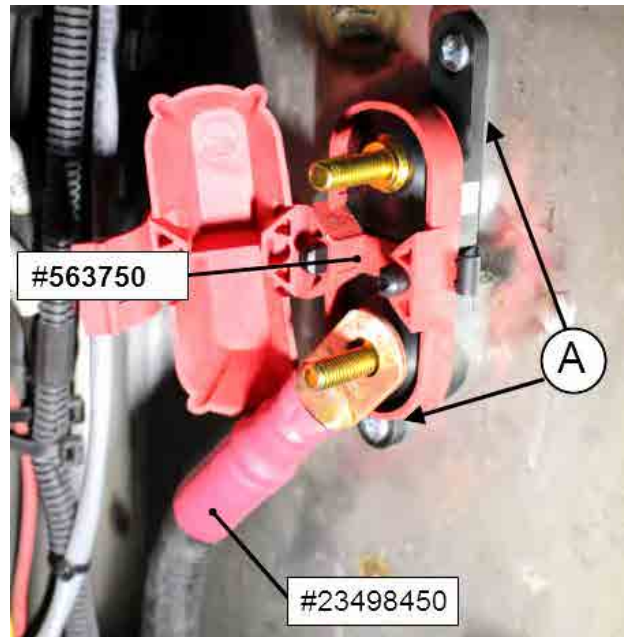
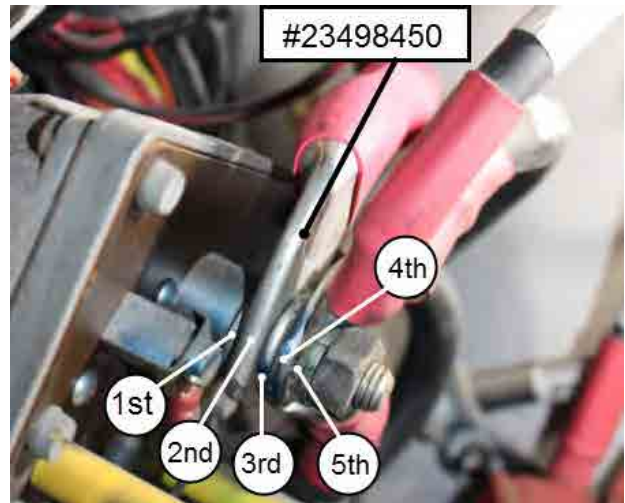

FIGURE 141

120. Reinstall the four (4) other cable lugs to the master relay R1 upper post.

**Being the largest lug at R1, the cable #23498450 lug should be placed first on the post (behind all the other lugs) (or second if rubbing is likely to happen).**

**Master relay R1- Port 30 – M10-1.5 stud nut torque: 160-195 lb-in (18-22 Nm)**



**FIGURE 142: ON THIS PICTURE, CABLE #23498450 LUG IS IN SECOND (2<sup>ND</sup>) POSITION BECAUSE IT WAS LIKELY TO RUB ON THE HEAD OF ONE OF THE FOUR SCREWS.**

121. Reinstall the master relay R1 cover.

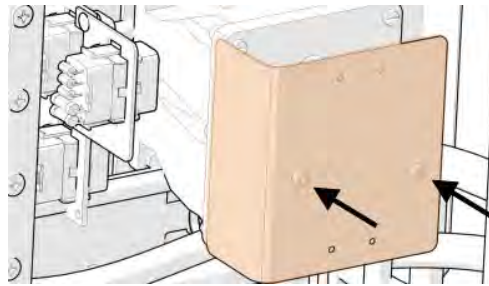

**FIGURE 143**

122. Place the **300A fuse #564520** in the fuse holder underneath the cable lugs.

123. Connect to the free post of the fuse holder the two (2) following cables that are routed from the alternator and the fan drive circuit breakers box:

- Fan drive power cable #23498721
- L.H. alternator power cable #23524934

**A: nut #5001983 (2x)**

**B: washer #5001341 (2x)**

Thread the nuts and tighten to a torque of 96 lbf-in (11Nm).

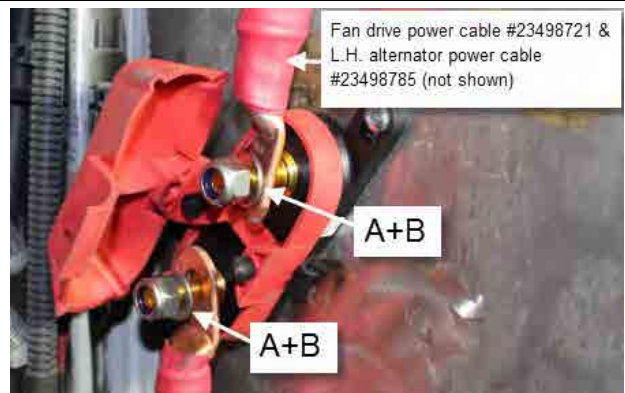

**FIGURE 144: TAKE NOTE THAT THE 300A FUSE IS NOT PRESENT ON THE PICTURE ABOVE BUT IT SHOULD BE INSTALLED AT THIS STEP**

124. Secure the “fan drive power” cable and the “L.H. alternator power” cable as shown on the pictures at right using the following parts:

**A: tie mount #509490 (2x)**

**B: rivet #504610 (2x)**

**C: nylon tie #509491 (3x)**

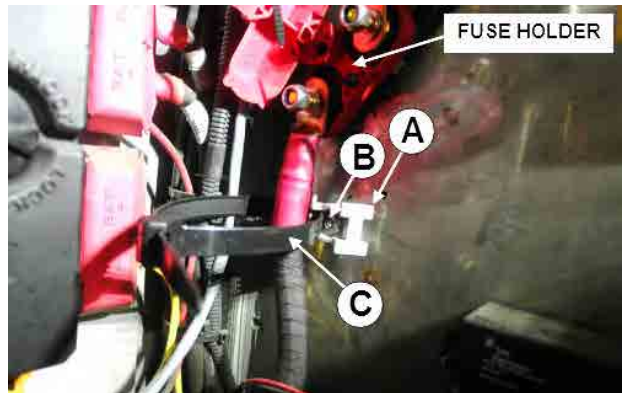

FIGURE 145

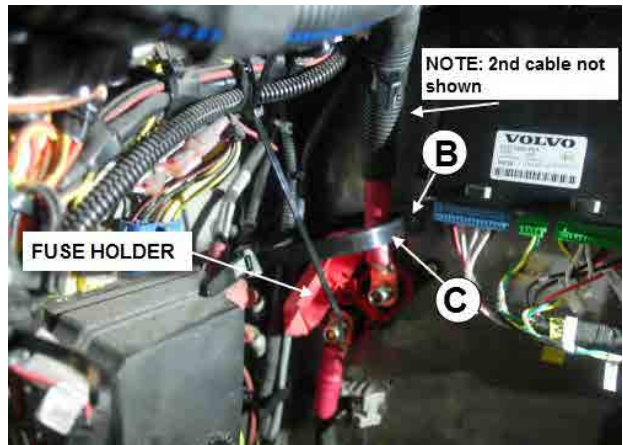

FIGURE 146

125. Install the MCM #23499009\_EFD and the I/O-B module #2272850 on the bulkhead.

- Spacing between the I/O-B and the MCM=1 inch
- Pilot holes diameter: 11/64”

Install with the following hardware:

**Tapping screws #500658,**

**3x for the MCM**

**4x for the I/O-B module**

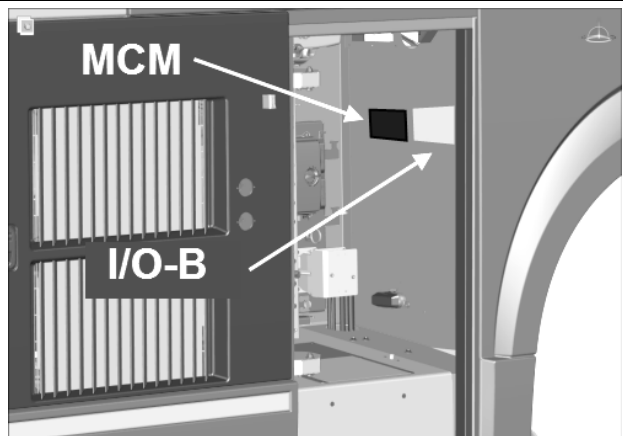

FIGURE 147: MAIN POWER COMPARTMENT

126. In the main power compartment, connect the "fan to RJB interface harness" to the "MCM to I/O-B interface harness" #23445869 by means of connector C-EFD1.
127. Connect the MCM and the I/O-B module together using the "MCM to I/O-B interface harness" #23445869.
128. Connect the OEL resistors connector **RES1F** and **RES2F** (part #563593) to the "MCM to I/O-B interface harness". See the image at right and the following pictures for reference.

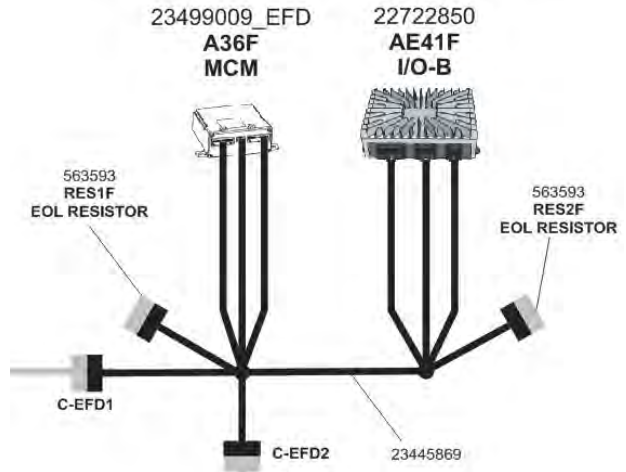

FIGURE 148



FIGURE 149

**A:** nylon tie #504016 (3x)



FIGURE 150

**A:** nylon tie #504016 (2x)

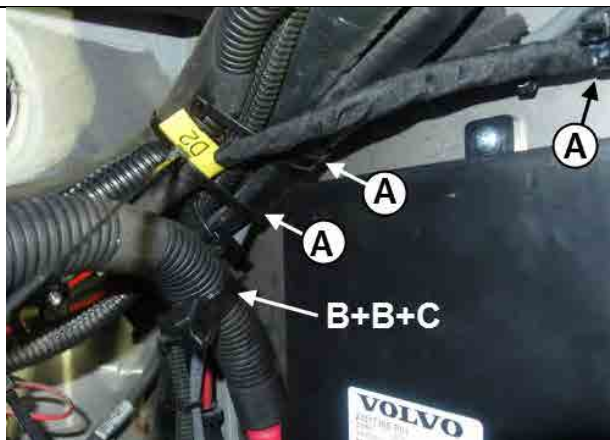

FIGURE 151

**A:** nylon tie #504016 (3x)

**B:** nylon tie #509491 (2x)

**C:** swivel mount #504751 (1x)



FIGURE 152

**B:** nylon tie #509491 (2x)

**C:** swivel mount #504751 (1x)

129. In the main power compartment, connect the **“vehicle interface harness” #23490553** to the **“MCM to I/O-B interface harness”** by means of connector C-EFD2.

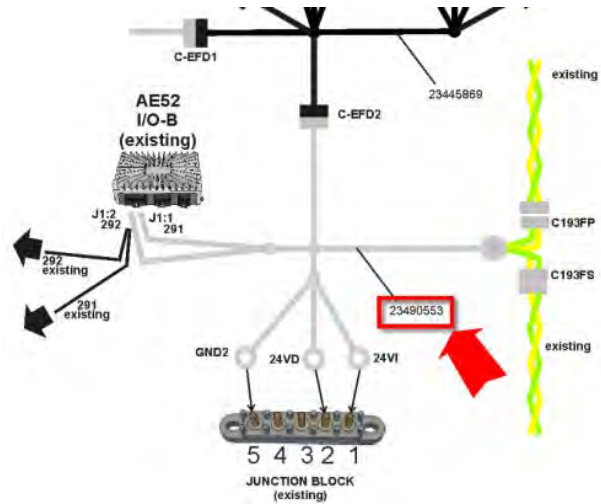

FIGURE 153

130. Connect circuit 24VI, 24VD & GND2 to post 1, 2 & 5 respectively of the junction block.

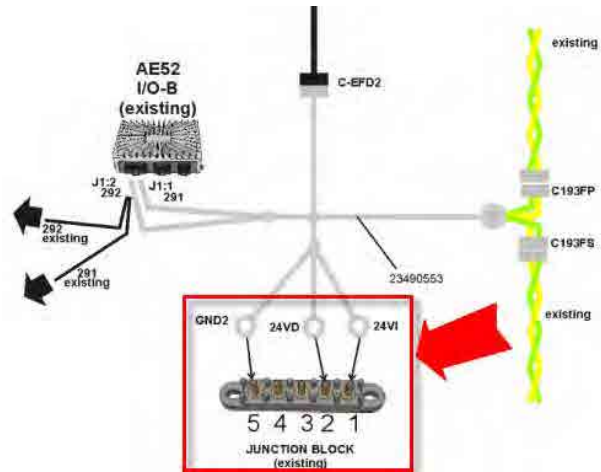

FIGURE 154

131. Get the J1939 signal. To do so, locate connector C193 among the existing harnesses in the main power compartment.
132. Disconnect connector C193 and connect with C193FS and C193FP of the **“vehicle interface harness” #23490553**.

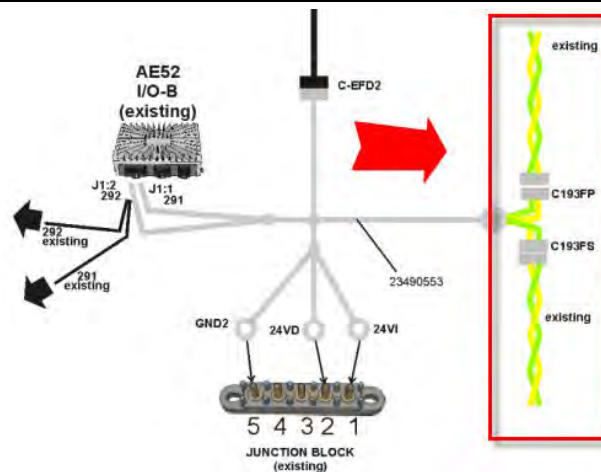

FIGURE 155

133. In the main power compartment, locate I/O-B module A52 (alternately named AE52).
134. At **A52** (or AE52), remove existing circuit 291 and 292 from connector J1:1 (pin 1) and J1:2 (pin 2).
135. For each circuit, cut the terminal and put a heat shrinking sleeve at the end of the wire. Those circuits won't be used anymore.
136. Insert circuit 291 and 292 of the "**vehicle interface harness**" #23490553 into connector J1 pin 1 and J1 pin 2 respectively.

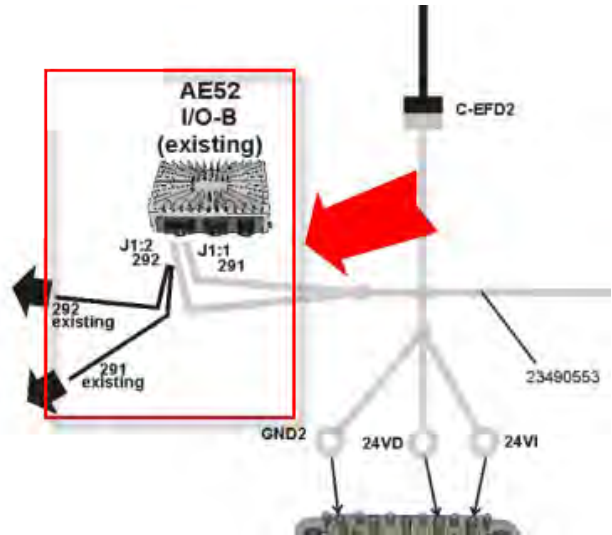

FIGURE 156

137. On the bulkhead, install the **alternator telltale bracket #050303**. Fasten to the bulkhead using two (2) rivets #504379.
138. Place the alternator telltale **insert #391028** in the **telltale light module #562113**.
139. Connect the appropriate branch of the "fan to RJB interface harness" to the telltale light module.

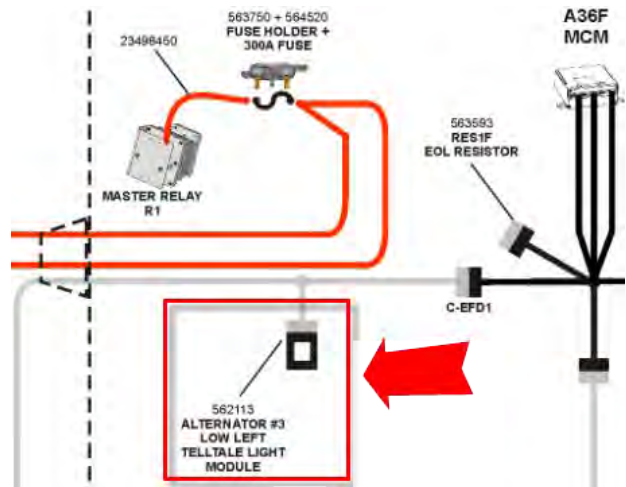

FIGURE 157



FIGURE 158

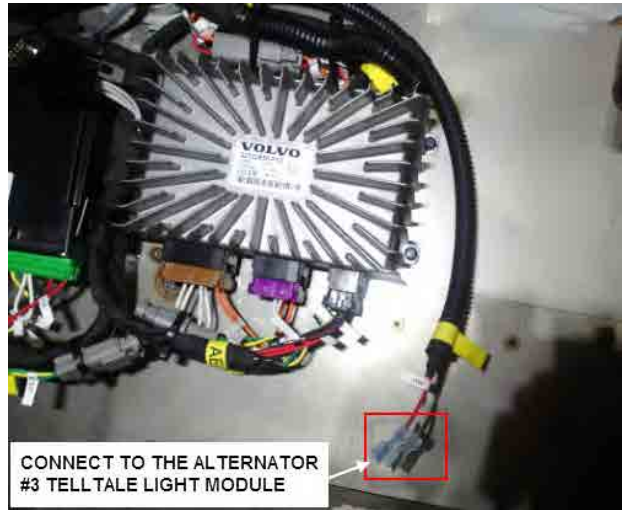

FIGURE 159

140. There are remaining nylon ties and tie mounts in the kit. Use them to secure the harnesses and cables that may seem loose. The goal is to prevent rubbing of the cables and harnesses.

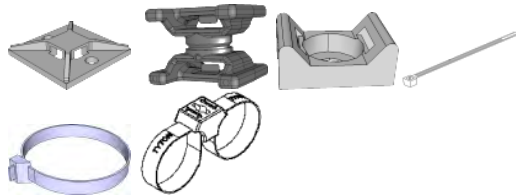

FIGURE 160

141. Install one (1) warning decal #069205 as shown on the image.



FIGURE 161

142. Install a second warning decal #069205 as shown on the radiator door.

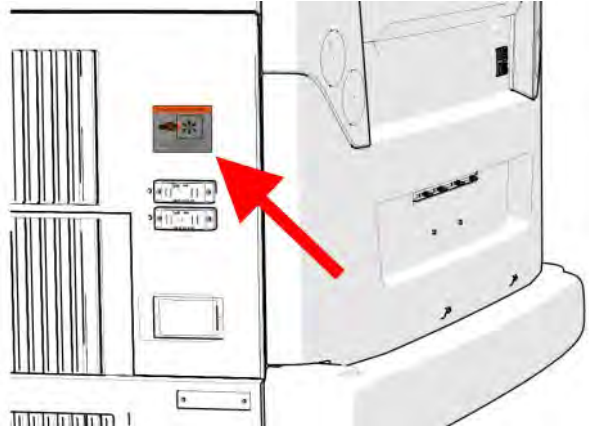

FIGURE 162

143. Fasten the radiator door **upper arm assembly**.

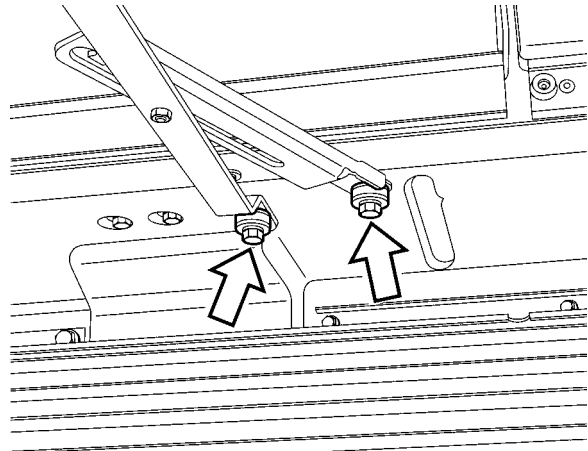

FIGURE 163

144. Refill the cooling system. Connect coolant extractor. Use coolant extractor to refill the coolant from the engine.

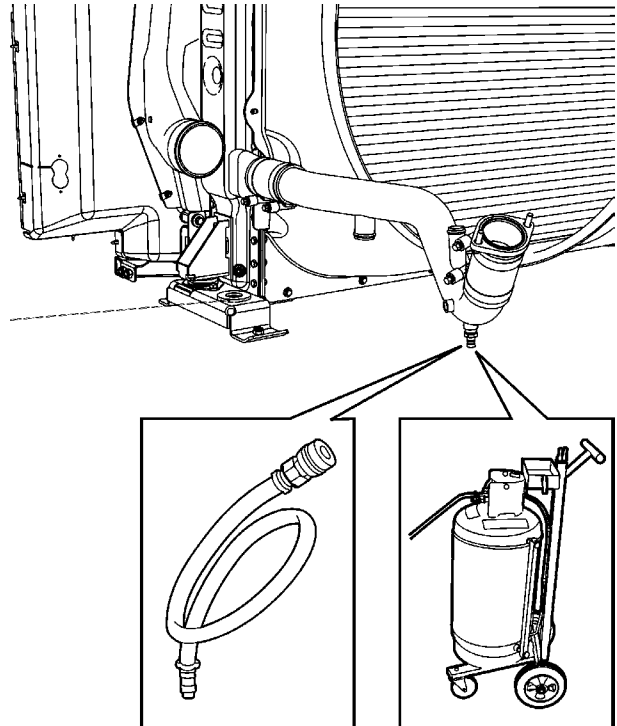

FIGURE 164

145. Reinstall the rear bumper.

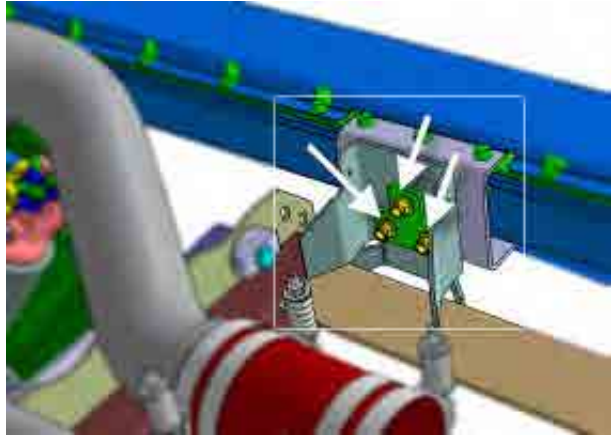

FIGURE 165

146. Reinstall the **access panel** located behind tag axle L.H. side wheel.

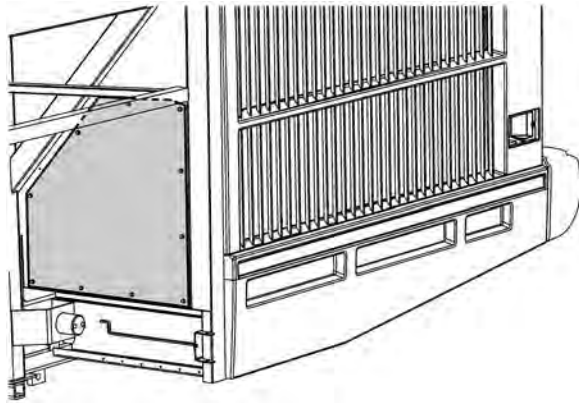

FIGURE 166

147. Reinstall L.H. side **rear fender**.

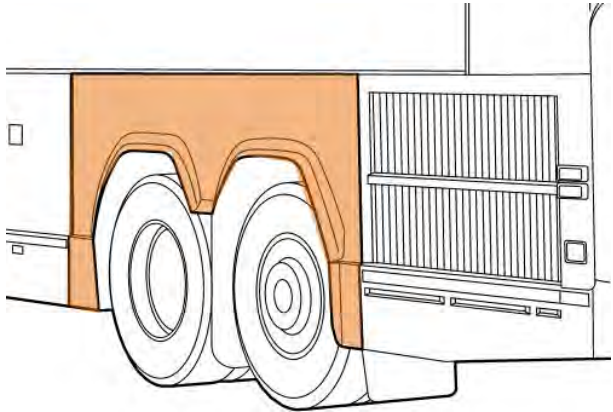

FIGURE 167

148. Follow the specific instructions for programming of the newly installed multiplex modules.

## PARTS / WASTE DISPOSAL

Discard waste according to applicable environmental regulations (Municipal/State[Prov.]

Federal)