

PREVOST

Instruction Sheet

IS-19906





BOSCH TO DELCO REMY ALTERNATOR INSTALLATION, X3-45 WITH ELECTRIC FAN DRIVE

MATERIAL

Order Main Kit **IS19906**, which contains









Part No.	Description	Qty
0610086	Alternator Mechanical Kit, Right	1
0610087	Alternator Mechanical Kit, Left	1
0610091	Adaptation Kit, Right, X3-45	1
0610107	Adaptation Kit, Left, X3-45	1
0610108	Boost Regulator Kit, EFD	1
IS-19906	Instruction Sheet	1
FI-19906	Feuille d'instructions	1

0610086 Alternator Mechanical Kit, Right

Part No.	Description		Qty
560720	Alternator Remy 55SI 24V-250A PadMount		1
069892	Pulley 8PK, 83 DOB		1
069894	Bracket, Alternator Remy		1
506065	Belt Poly V 8PK1435 EPDM QT+Aramide		2
5001308	SCR CAP HEXF N500 M10-1.5X40 G10.9		4
5002091	SCR CAP HEXF N500 M10-1.5X120 G10.9		4
5001137	WSH FL SS .203X.438X.06 (M5,#10)		2
5001180	NUT HEX NYRT SS 10-24		2
500411	WSH FL SS .260X.697X.05 (M6,1/4)		1
5001341	WSH FL SS 8.4X17X1.6 (M8,5/16)		1

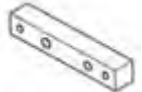

500685	NUT HEX NYRT 5/16-18 SS		1
--------	-------------------------	---	---

0610087 Alternator Mechanical Kit, Left

Part No.	Description		Qty
560720	Alternator Remy 55SI 24V-250A PadMount		1
069893	Pulley 10PK, 69 DOB		1
010090	LH alternator engine support		1
069890	Bracket, Alternator Remy LH lower		1
069891	Bracket, Alternator Remy LH upper		1
061502	Cable support transition		1
010111	Decal, M4 Mot Belts FES		1
506067	Belt Poly V 10PK1703 EPDM QT+ Aramide *1		2
5001308	SCR CAP HEXF N500 M10-1.5X40 G10.9		4
5002091	SCR CAP HEXF N500 M10-1.5X120 G10.9		4
5001137	WSH FL SS .203X.438X.06 (M5,#10)		2
5001180	NUT HEX NYRT SS 10-24		2
500411	WSH FL SS .260X.697X.05 (M6,1/4)		1
5001341	WSH FL SS 8.4X17X1.6 (M8,5/16)		1
500685	NUT HEX NYRT 5/16-18 SS		1
504379	RIVET POP DOME OE 3/16x1/4 SS		6
0610037	Control wiring harness LH alternator		1
0610035	Ground cable LH alternator		1

0610091 Adaptation Kit, Right, X345

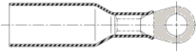

Part No.	Description		Qty
----------	-------------	--	-----

450580	BRACE, AC COMPRESSOR		1
5000360	STUD, M10-1.5X52 N500		1
N55439-02	RING TERMINAL 5MM / 16-14 / INSULATED		2
N33509-06	Shrink tubing		12"
0610030	Power cable RH alternator X345		1
0610034	Ground cable RH alternator		1

0610107 Adaptation Kit, Left, X345



Part No.	Description	Qty
0610031	Power cable LH alternator X345	1

0610108 Boost Regulator Kit, EFD

Part No.	Description		Qty
0610001	Support Boost Regulator		1
560629	Boost Regulator		1
5001975	SCR TC BDG PH SS410 Z050 10-24X3/8		4
5001137	WSH FL SS .203X.438X.06 (M5,#10)		3
0610042	Boost regulator harness		1
0610036	Control wiring harness RH alternator		1



Other parts not provided in the kit; shop supplies

Part No.	Description		Qty
504016	CABLE TIE, 5/16" X 14"1/2		A/R
507664	CABLE TIE, DOUBLE LOOP		A/R
509491	CABLE TIE, WIDE 13MM x 383MM		A/R
504637	CABLE TIE / 3/16" x 13"		A/R
684013	COLOR GUARD RUBBER COATING, 14.5 OZ CAN		A/R

680038	LOCTITE 243, BLUE,50ml		A/R
680100	LOCTITE 271, RED, 250ml		A/R
-	Brake cleaner		A/R

Preliminary version Jan 31, 2019

TOOLS

<p>15/16" THIN WALL CROWFOOT ADAPTER.</p> 	<p>060088 CLUTCH EXTRACTOR</p> 	<p>Extractor tool Prevost 682256 VECR</p> 
<p>Deutsch extractor Prevost 682321 C397</p> 	<p>Extractor tool Prevost 568103 IOEB</p> 	<p>RATCHET AND SOCKET SET - METRIC</p> 
<p>HEX BIT SOCKET SET - METRIC</p> 	<p>METRIC OPEN END WRENCH SET</p> 	<p>SOFT FACED HAMMER</p> 
<p>1 5/8" OPEN END WRENCH</p> 	<p>TORQUE WRENCH</p> 	<p>1/2" SQUARE DRIVE BREAKER BAR</p> 
<p>VOLTMETER / MULTIMETER</p> 	<p>BELT TENSION GAUGE</p> 	<p>RIVETER</p> 
<p>CUTTING PLIERS</p> 		

PROCEDURE



DANGER

Park vehicle safely, apply parking brake, stop engine. Prior to working on the vehicle, set the ignition switch to the OFF position and trip the main circuit breakers equipped with a trip button. On Commuter type vehicles, set the battery master switch (master cut-out) to the OFF position. Apply vehicle lockout procedures according to local policies.

Table of contents

OVERVIEW	6
ELECTRICAL SCHEMATICS	7
CONNECTOR PINOUT REFERENCE	9
BOSCH ALTERNATORS REMOVAL, RIGHT HAND SIDE	10
RIGHT HAND ALTERNATOR INSTALLATION	15
RIGHT HAND ALTERNATOR INSTALLATION (CONTINUED)	17
RIGHT HAND ALTERNATOR CONNECTIONS	22
BOSCH ALTERNATOR REMOVAL, LEFT HAND SIDE	25
LEFT HAND ALTERNATOR INSTALLATION	31
LEFT HAND ALTERNATOR CONNECTIONS X3-45	37
BOOST REGULATOR INSTALLATION - X SERIES- EFD	38
MULTIPLEX PROGRAMMING	42
FUNCTIONAL TESTING	42
APPENDIX A – LTD WIRE GUIDELINES	43
LABOR REFERENCE TABLE	45

OVERVIEW

The procedure involves removing the three existing Bosch alternators, their corresponding brackets and harnesses and replacing them with a pair of DelcoRemy 55SI alternator.

The alternators require new brackets and harnesses. A boost regulator and corresponding harness is also added in the main power compartment. Reprogramming the vehicles' MUX program is required.

First time users should read the procedure before starting work on a vehicle. Best viewed in color.

ELECTRICAL SCHEMATICS

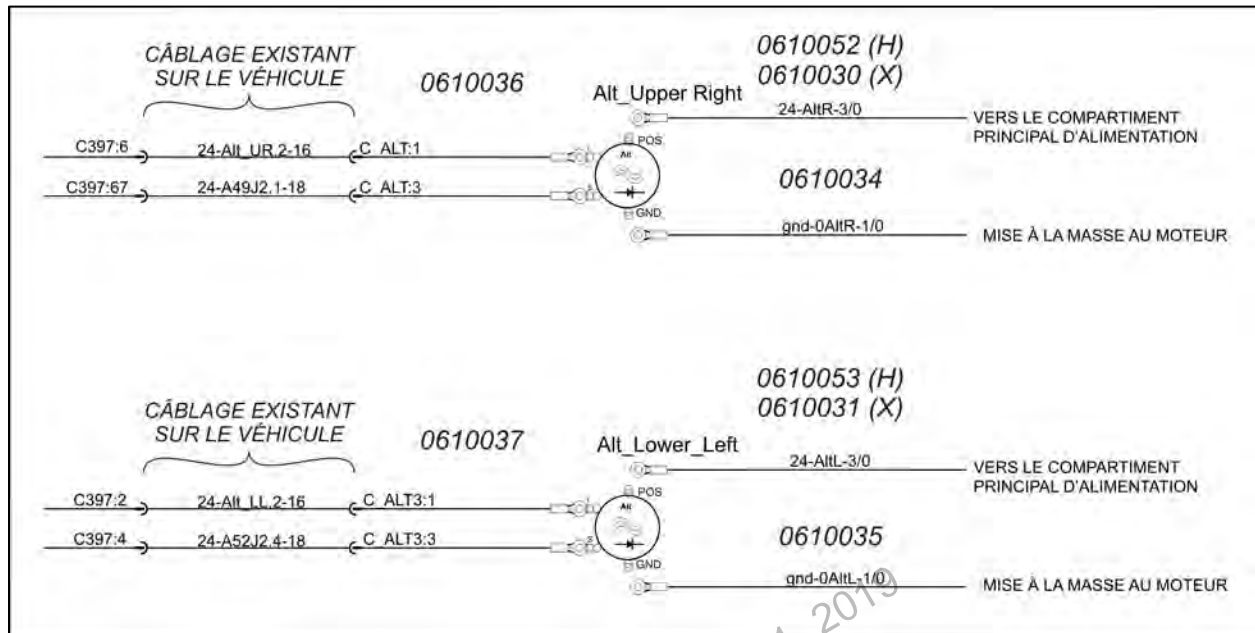

FIGURE 1: ALTERNATOR CONNECTIONS W/ HARNESS NUMBERS

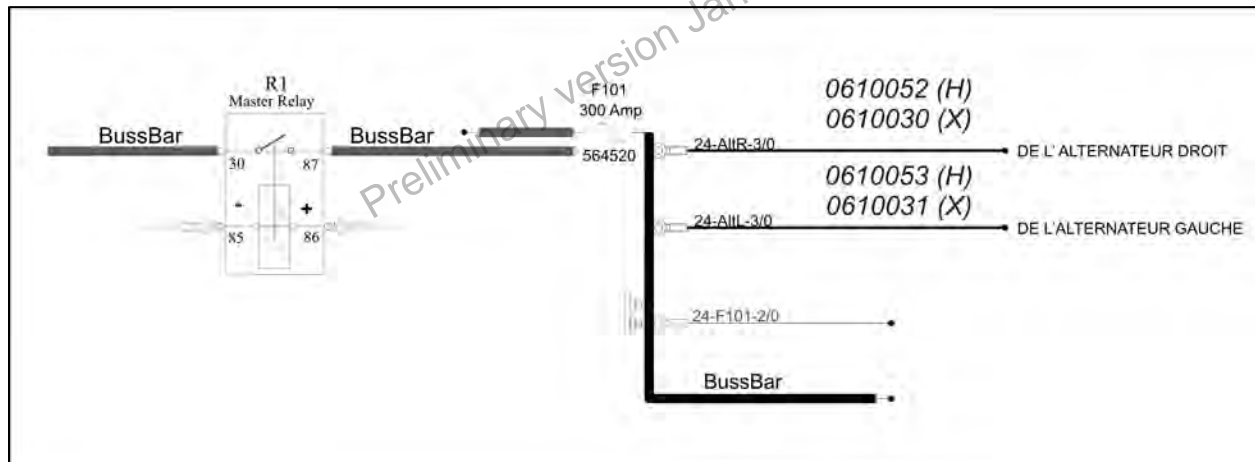

FIGURE 2: POWER CABLE CONNECTIONS IN MAIN POWER COMPARTMENT

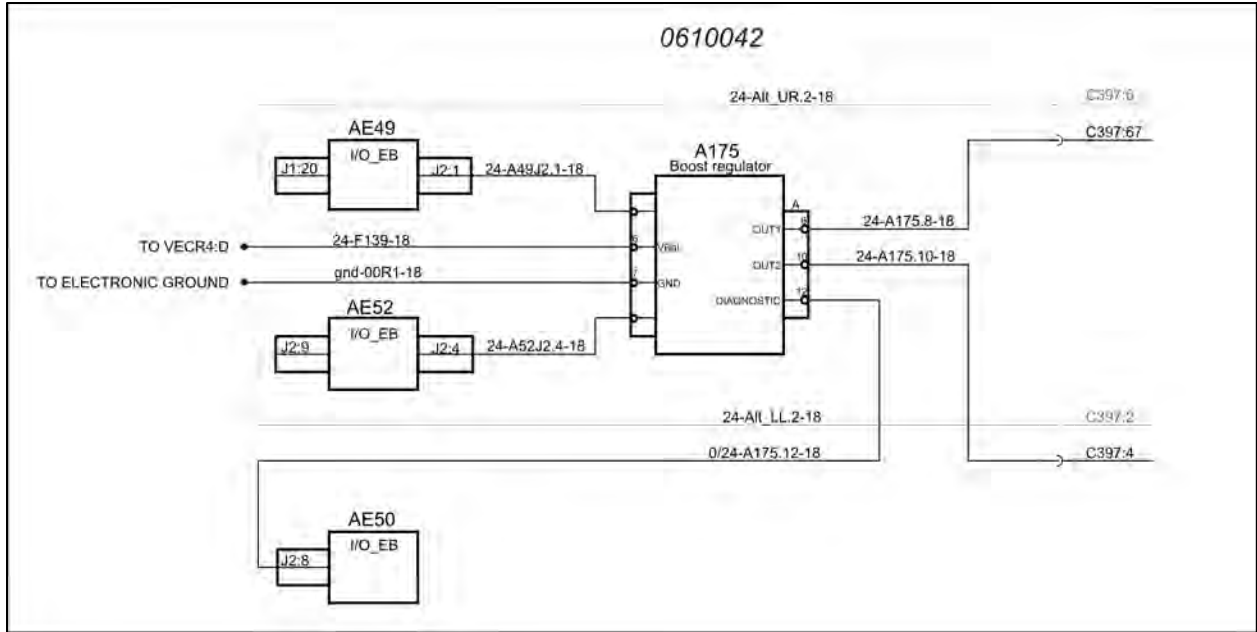

FIGURE 3: BOOST REGULATOR / HARNESS 0610042 CONNECTIONS IN MAIN POWER COMPARTMENT

Preliminary version Jan 31, 2019

CONNECTOR PINOUT REFERENCE

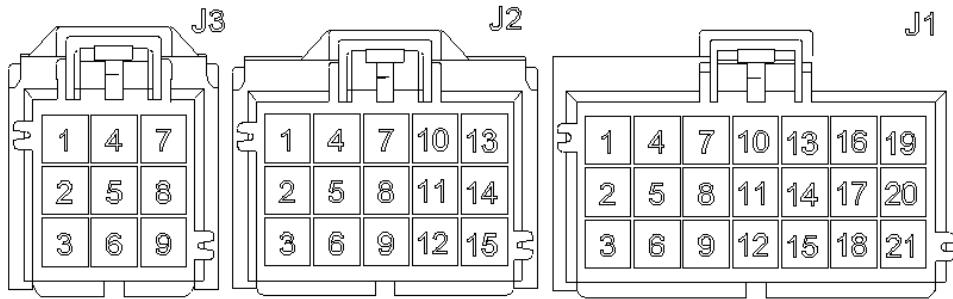

FIGURE 4: IOEB PINOUT

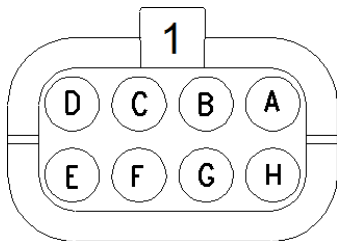

FIGURE 5: VECR TYPICAL PINOUT

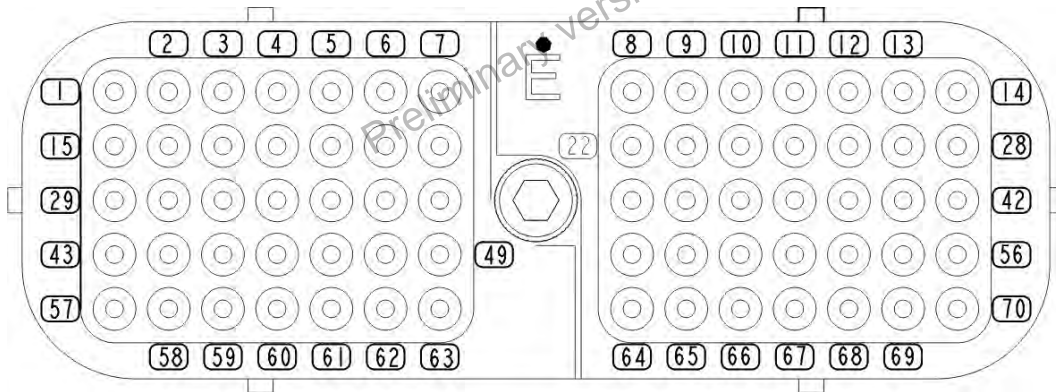

FIGURE 6: C397 PINOUT

BOSCH ALTERNATORS REMOVAL, RIGHT HAND SIDE

1. Loosen bolt **A** on A/C belt tensioner.
2. Unscrew and remove nut **B**.
3. Remove the mechanical tensioner assembly.
4. Remove the A/C compressor drive belts (2 side-by-side belts).

Note: Keep hardware for reuse

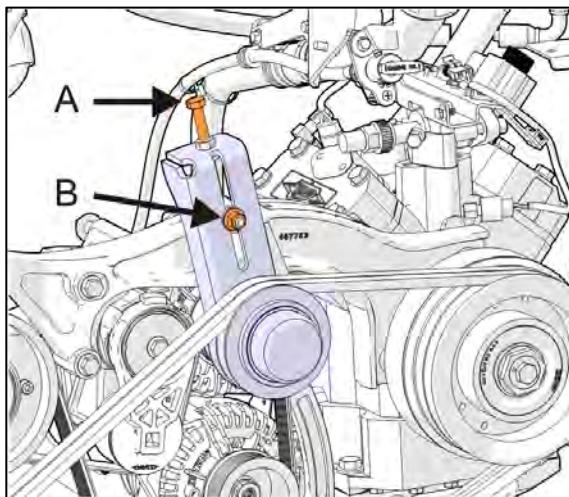

FIGURE 7

5. Remove the LANG electromagnetic clutch assembly.

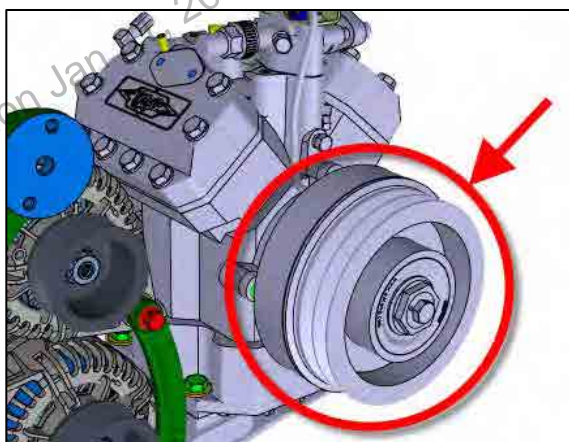
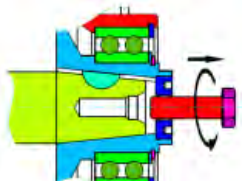

FIGURE 8

6. Hold the rotor with the 1 5/8 wrench. Loosen and remove the M12 rotor mounting screw.



REMOVING THE M12
SCREW



FIGURE 9

For the next step, use rotor extractor tool #680888.

7. Screw the extractor tool into the straining washer only until the rotor pops off the tapered shaft. Then work the rotor off the shaft by hand with help from soft faced mallet as needed.

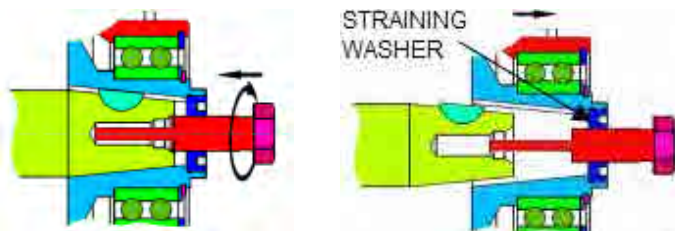

PULL OFF THE ROTOR WITH TOOL #680888 (shown)

TAKE OFF THE ROTOR
FIGURE 10

8. Loosen the fastening screws (4x) of the coil and pull the coil off the retainer.



FIGURE 11

9. Remove the support bracket mounting bolts on the engine. Reserve.
10. Remove the belt tensioner bolt. Reserve for re-use.
11. Remove and discard the alternator drive belt.

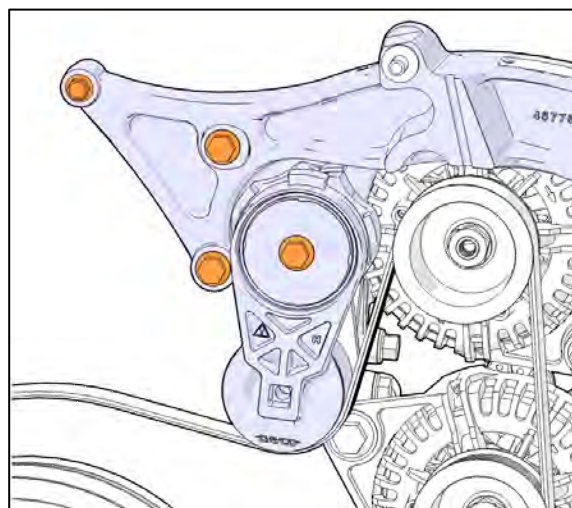

FIGURE 12

12. Unscrew and remove two socket cap screws.
13. Discard the reinforcement bracket.
14. Keep hardware for re-use.

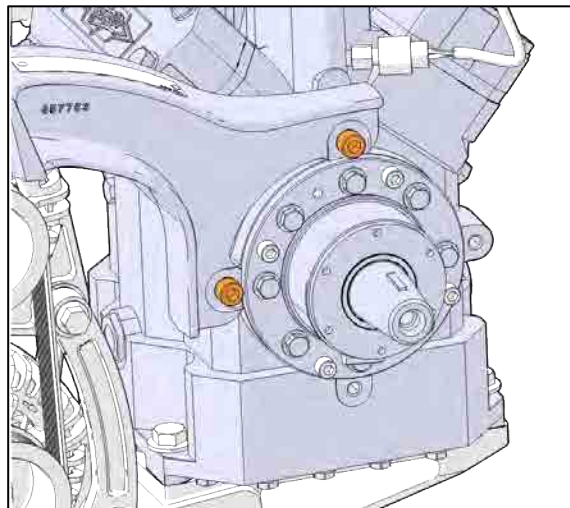

FIGURE 13

15. Remove compressor mounting bolts and reserve. Move compressor slightly aside to provide working space.

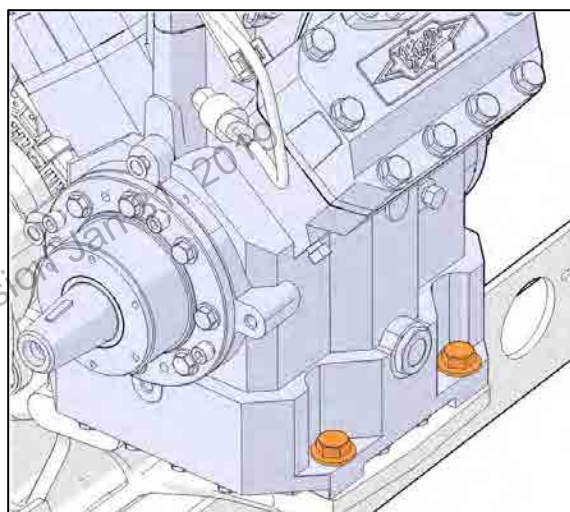

FIGURE 14



WARNING

The alternator is connected to the batteries through master relay R1. If the ignition switch is in the OFF position and the battery master switch (master cut-out) is set to the OFF position, there should not be electrical power to the alternator terminals. However, a faulty master relay R1 could eventually leave the battery power circuit closed, thus electrical power would be present at the alternator terminals.

Using a multimeter, probe the alternator **B1+** terminal and the ground terminal. Make sure that the voltage reading is 0 volt before disconnecting the alternator cables.

16. Disconnect the *Power, Jumper, Control Harness* and *Ground* cables from the alternators. Discard.
17. Do not dismantle the power cable yet. This will be done when installing the new cable.

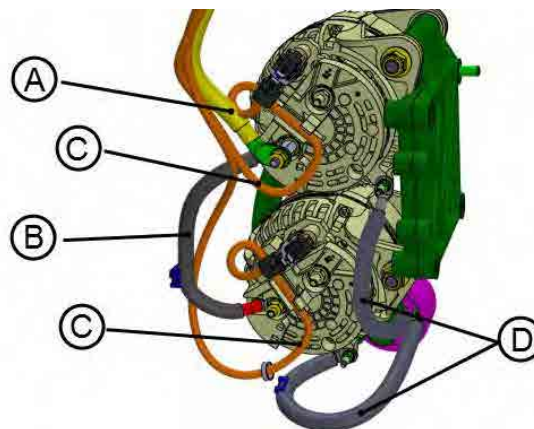

FIGURE 15

- A: (+) POWER CABLE
- B: (+) JUMPER CABLE
- C: CONTROL HARNESS
- D: GROUND CABLE

18. Remove the existing alternators. To do so, unscrew the four (4) mounting bolts identified on the figure. Discard bolts and alternators.
19. Also remove the idler at the bottom. Discard idler and hardware.

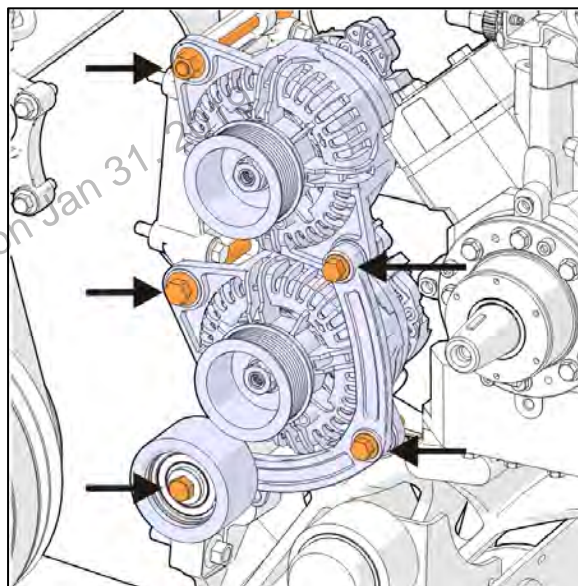

FIGURE 16

20. Remove the alternator support bolted on the engine. Discard support and bolts.

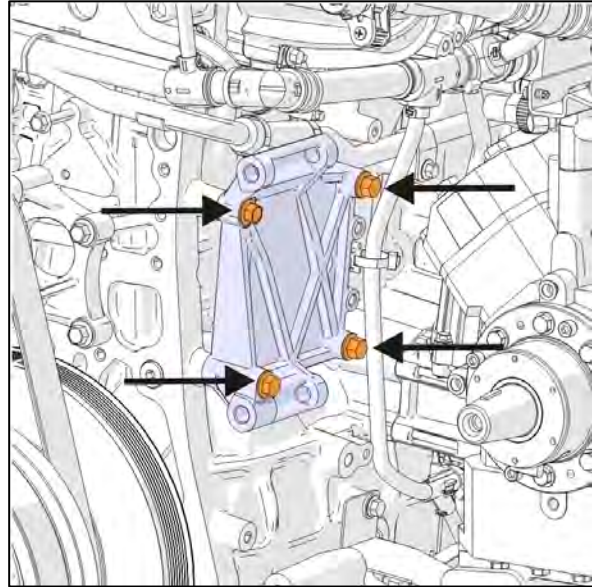

FIGURE 17

Preliminary version Jan 31, 2019

RIGHT HAND ALTERNATOR INSTALLATION

21. Installing the alternator pulley.

Place 560720 alternator flat on a bench with the shaft horizontal.

Required tools:

- 15-16" crowfoot adapter
- 8mm hex bit

Clean shaft and pulley with brake cleaner.

Slide pulley 069892 on shaft by hand.

Hand thread nut on shaft until snug.

Using 15/16" adapter and 8mm hex bit to block shaft rotation, tighten to **70-80 lb-ft**.

Apply torque seal

Never use power tools to install pulley and nut.

Note: Do not apply any pressure to end of the shaft. Internal damage may occur if the shaft is pushed back and turned.

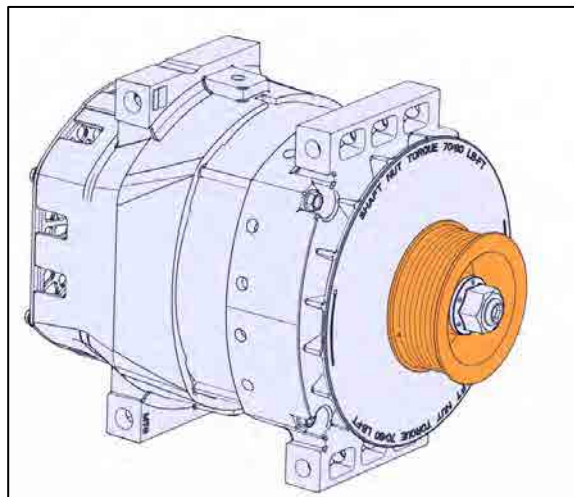

FIGURE 18

22. Install bracket 069894 on engine with four (4) 5001308 M10x40 bolts.

Apply blue Loctite 680038

Tighten to **35 lb-ft**.

Apply torque seal.

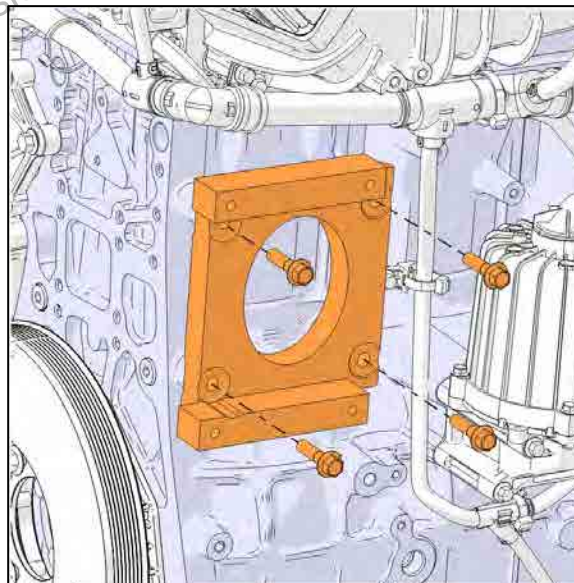

FIGURE 19

23. Install alternator on engine with four (4)
5002091 M10x120 bolts.

Apply blue Loctite 680038

Tighten to **48 lb-ft**

Apply torque seal.

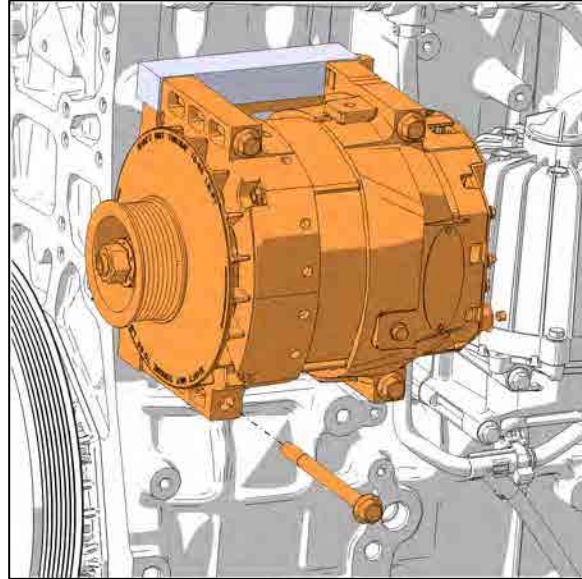

FIGURE 20

Preliminary version Jan 31, 2019

RIGHT HAND ALTERNATOR INSTALLATION (continued)

24. Install stud 5000360 with Red Loctite 271 on new modified compressor brace 450580. Install it so it exceeds by 25mm.

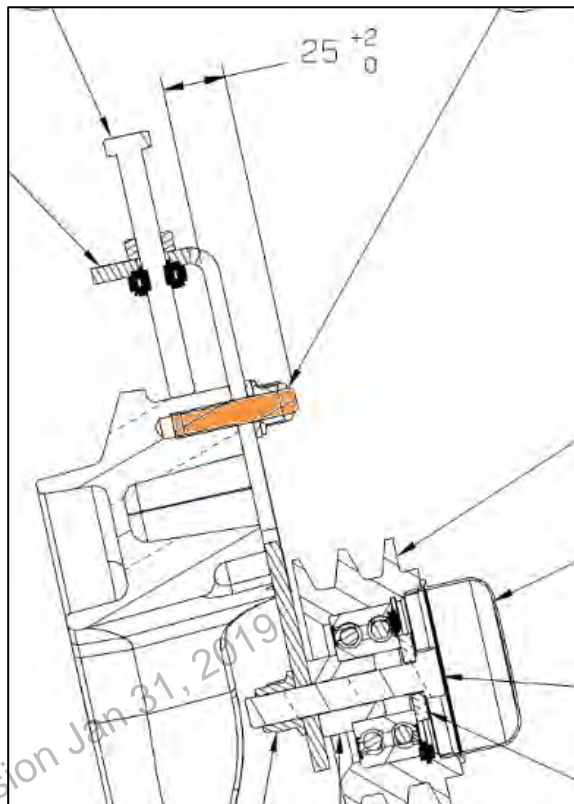

FIGURE 21

25. Install *modified** compressor brace support 450580.

Install reserved hardware by hand.

Tighten **C** to **43 lb-ft**

Tighten **D** to **22 lb-ft**

Tighten **E** to **40 lb-ft**

Apply torque seal.

*450580 is modified with clearance for the Alternator fan and a different indexation angle for the tensioner.

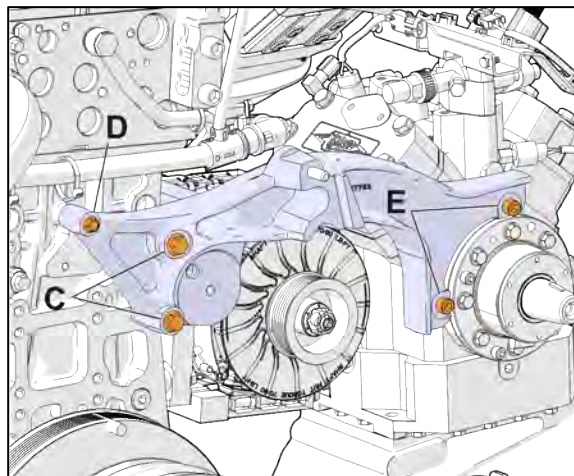

FIGURE 22

26. Install the alternator belt tensioner with hardware **E** reserved earlier.

Tighten to **48 lb-ft**.

Apply torque seal

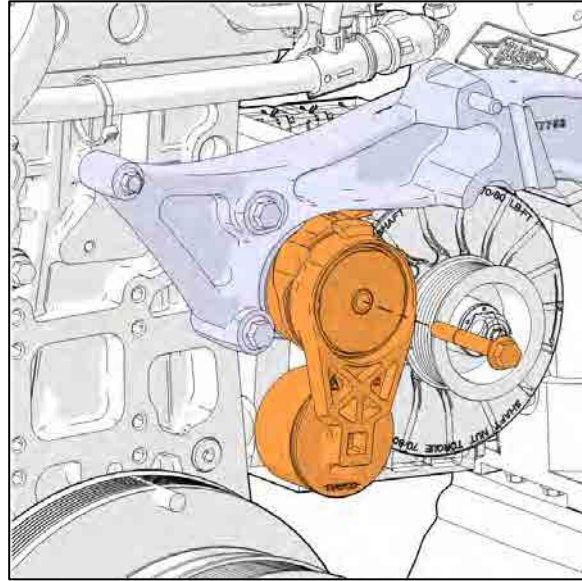

FIGURE 23

27. Install alternator belt 506065. To do so, rotate the automatic belt tensioner using a ½ square drive breaker bar

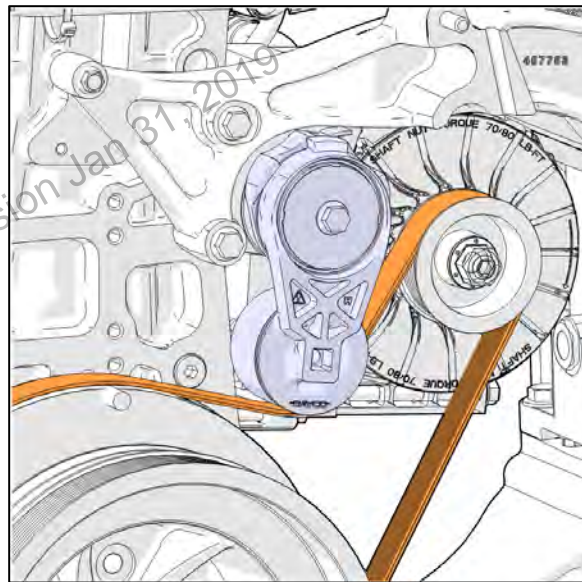

FIGURE 24

28. Install A/C clutch coil.

Use blue Loctite 243

Tighten to **22lb-ft**

Apply torque seal

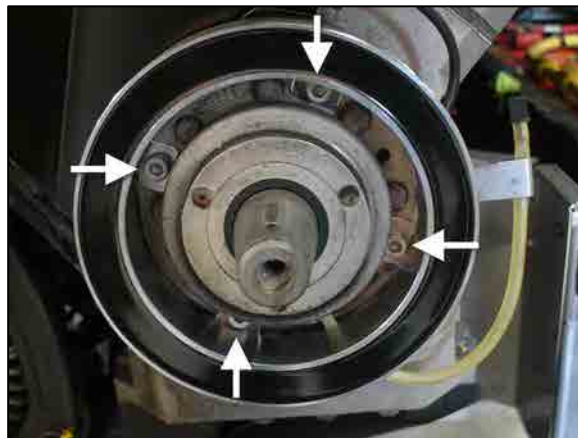

FIGURE 25

29. Mount the rotor on the shaft end.

The flange and the shaft end of the compressor must be free from dirt.

Apply high temperature approved assembly grease on the shaft end for easy dismounting of the clutch. Lang recommends the use of Molykote G-rapid-plus or Molykote P 40.

30. Carefully mount the rotor on the shaft end by hand.

Never use a hammer for pressing the rotor on.

Align the key on the compressor shaft with the keyway on the pulley bore. To avoid damaging the bore of the rotor, feel the engagement of the key in the keyway and slip the rotor on the shaft end of the compressor till reaching the stop.

The Woodruff key on the shaft end and the groove in the location hole of the rotor must be flush.



FIGURE 26

31. Fasten the rotor to the shaft end using the M12 screw and by holding-up with a wrench on the rotor.
32. Turn rotor by hand and pay attention to the free run and the generation of noises. In case of grinding or similar noises, dismount the clutch and check installation.

USE BLUE LOCTITE 243 ON THREADS

Tighten to **60lb-ft**

Apply torque seal

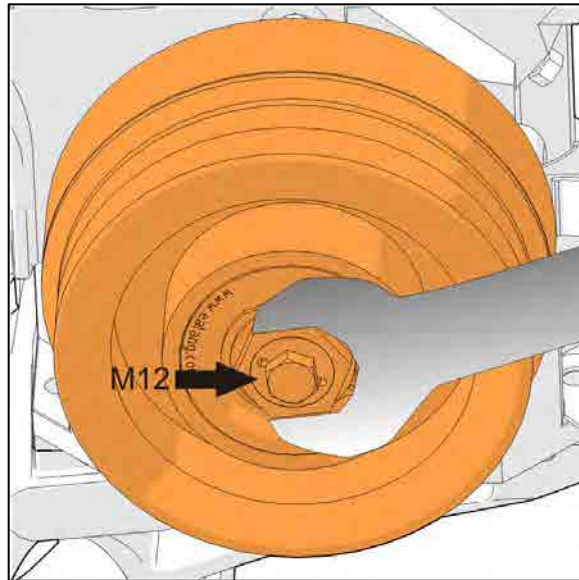

FIGURE 27

33. Re-install compressor mounting bolts. Tighten to **82 lb-ft**
Apply torque seal

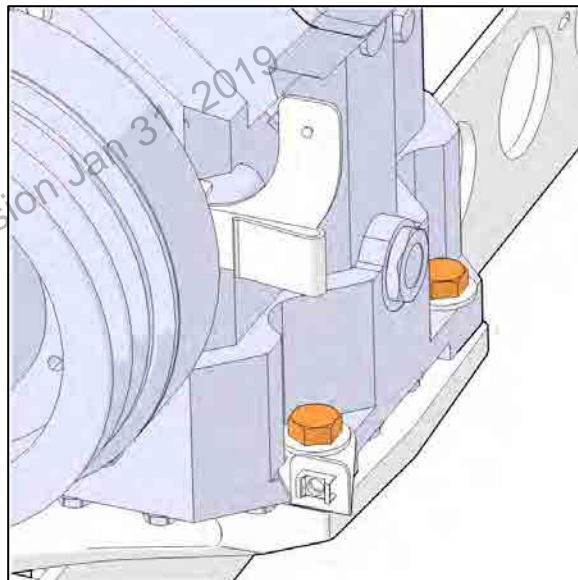

FIGURE 28

34. Re-install A/C belt tensioner and belt.

A belt strand tension gauge is needed. Belt tension should be within the following range:

- 90-100 lbs new belts (mean of 2 belt values)
- 75-85 lbs used belts (mean of 2 belt values)

35. Apply blue Loctite 243 on bolt **B** threads and then hand-tighten bolt **B**. Adjust belt tension using bolt **A**. Use the jam nut at the base of bolt **A** to keep proper tension adjustment.

Note: Once thread locker is applied, do not wait too long before applying final torque.

When proper tension is achieved, tighten bolt **B** to **43 lbf-ft.** (58 N-m).

Apply torque seal

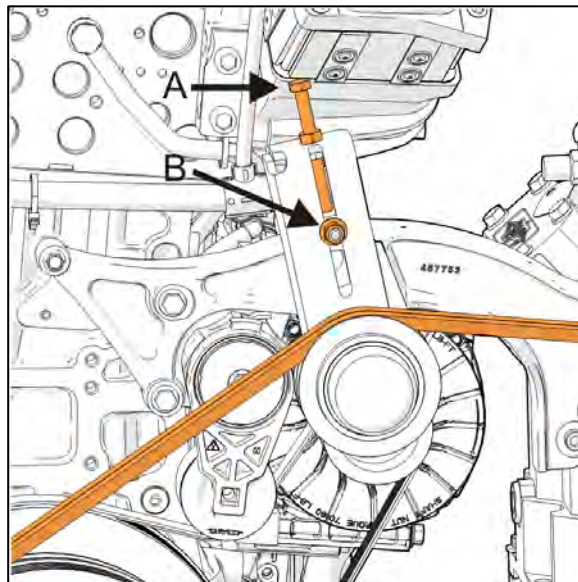

FIGURE 29

Preliminary version Jan 31, 2019

RIGHT HAND ALTERNATOR CONNECTIONS

36. Connect control harness 0610036.

Refer to ELECTRICAL SCHEMATICS

Use 5001180 10-24 Nylon lock nut and 5001137 washer.

Tighten to the following torque values:

Sense: **25-45 lb-in (3.0 5.0 N-m)**

Indicator: **25-45 lb-in (3.0 5.0 N-m)**

Apply color guard 684013 on connections.

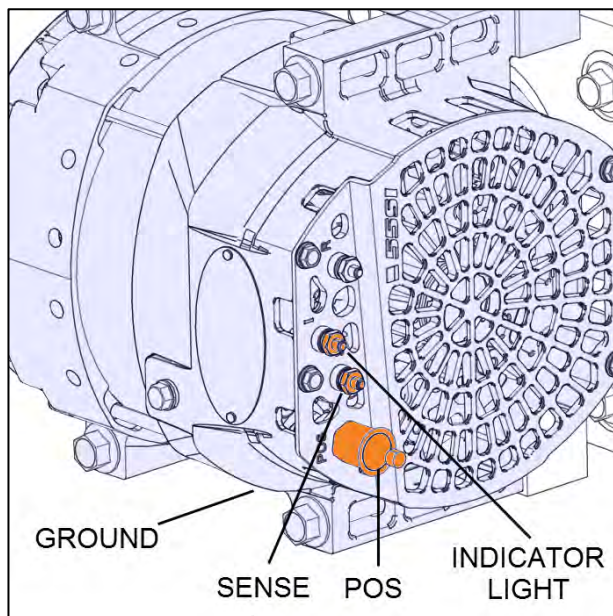

FIGURE 30

37. Route control harness up over the engine to C_ALT connector. (Figure 2)

Refer to ELECTRICAL SCHEMATICS;



FIGURE 31

38. Install ground cable 0610034 and power cable 0610030 on alternator.

Ground:

Add 500411 SS Washer.

Tighten to **50-60 lb-in (5.6-6.8 N-m)**

Positive:

Use 500685 Nylon lock nut and 5001341 SS Washer.

Tighten to **80-125 lb-in (9.0-14.0 N-m)**

Apply color guard 684013 on connections.

39. Connect ground cable to the engine.

Tighten to **240 lb-in.**

Apply color guard 684013 on connections.

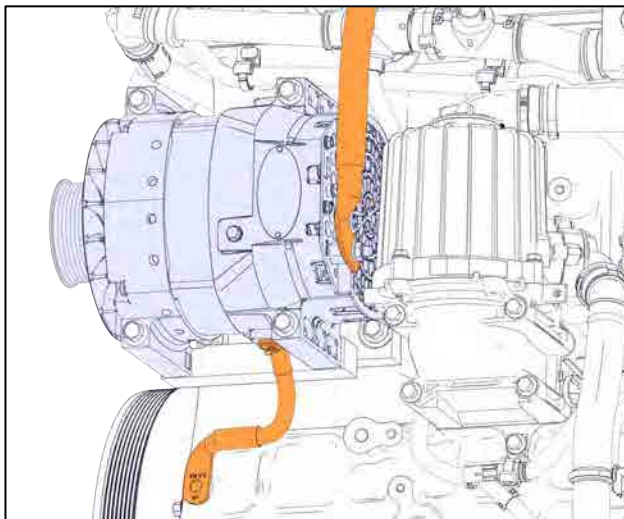

FIGURE 32

40. Secure control harness and power cable together with double loop cable ties as shown in images below.

41. If the red LTD wire was disturbed by dismantling of the Bosh wiring, secure it using the recommendations outlined in Appendix A "LTD wire guidelines".

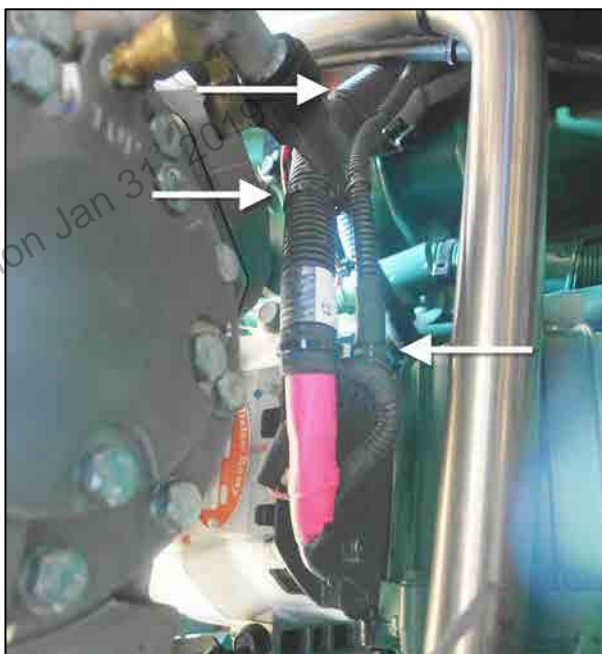

FIGURE 33

-
42. Route power cable from the main power compartment towards the engine.

Dismantle the former cable progressively, using the same routing, cable supports and mounting points as the previous power cable for the new power cable.

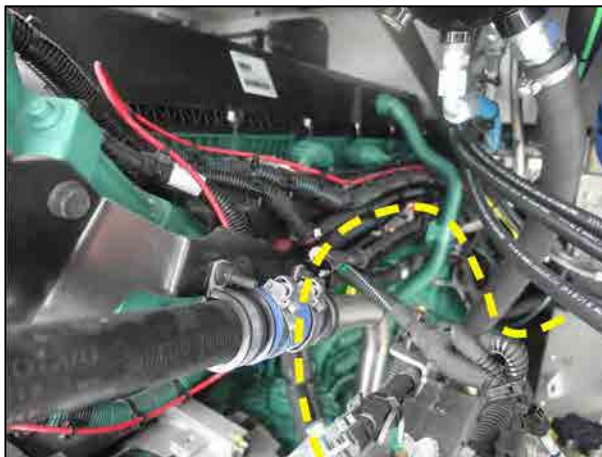

FIGURE 34

-
43. Connect to F101 24V junction block on the fore wall, under R1 relay.

Tighten to **96 lb-in**

Apply torque seal.

Refer to ELECTRICAL SCHEMATICS.



FIGURE 35

BOSCH ALTERNATOR REMOVAL, LEFT HAND SIDE



WARNING

The alternator is connected to the batteries through master relay R1. If the ignition switch is in the OFF position and the battery master switch (master cut-out) is set to the OFF position, there should not be electrical power to the alternator terminals. However, a faulty master relay R1 could eventually leave the battery power circuit closed, thus electrical power would be present at the alternator terminals.

Using a multimeter, probe the alternator **B1+** terminal and the ground terminal. Make sure that the voltage reading is 0 volt prior disconnecting the alternator cables.



WARNING

Parts of this procedure require access to the underside of the vehicle. Prevost recommends using mobile column lifts.



WARNING

Fully deflate the vehicle's suspension.

The engine will be supported during engine mount removal. Minute deflating of the air springs may unwillingly transfer some of the vehicle's weight to the engine while it is supported

1. Rotate the automatic belt tensioner **A** clockwise using a $\frac{1}{2}$ square drive breaker bar and then remove the alternator drive belt **B**.

Discard belt.

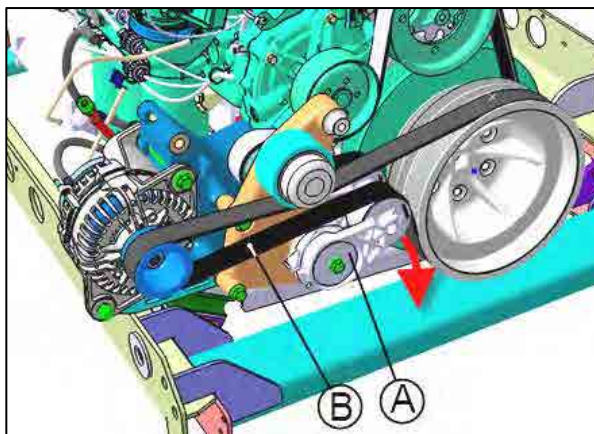

FIGURE 36

2. Cut the nylon ties securing the cables to the alternator and then disconnect the alternator cables **A, B & C**.

Move cables on the other side of the engine.

- A: (+) POWER CABLE**
- B: GROUND CABLE**
- C: ALTERNATOR HARNESS**

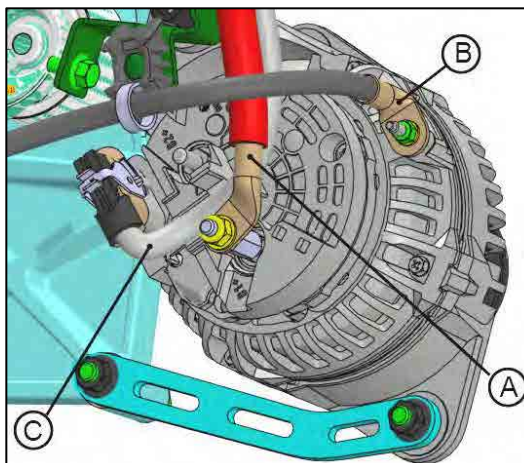

FIGURE 37

3. Remove the alternator. To do so, unscrew the two (2) mounting bolts identified on the figure.

Discard alternator.

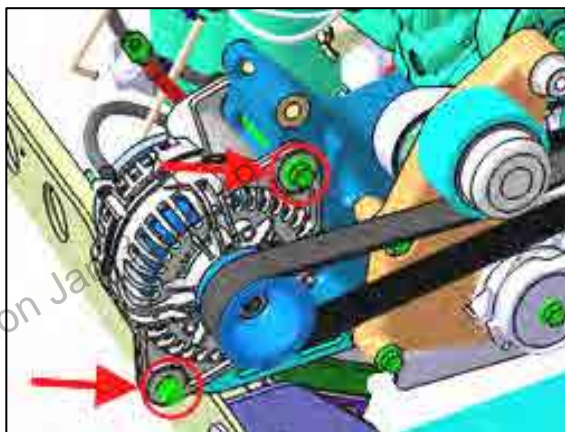

FIGURE 38

4. From under the vehicle, remove ground cable on engine mount, keep bolt and washer.



FIGURE 39

5. Remove screw holding the sloped cable support.
Transfer screw on new support 010090.



FIGURE 40

6. Remove the idler support
Keep hardware for reuse

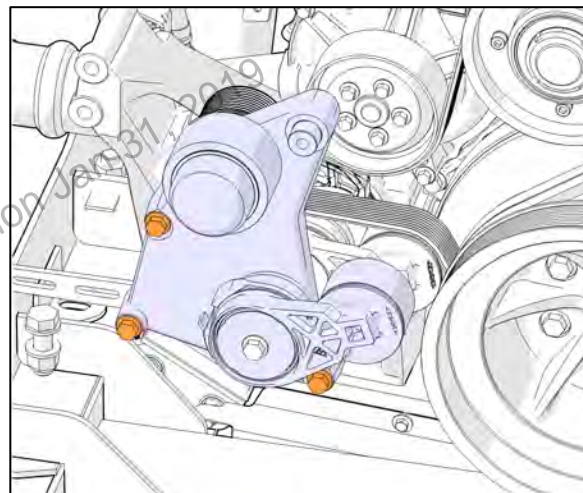

FIGURE 41

7. Remove water pump strap. Reserve.



FIGURE 42

8. Remove water pump idler / tensioner assembly mounting screws (3).
9. Reserve assembly. Keep hardware.
Idler/tensioner assembly will be reused as is.
Do not take apart tensioner or idler.

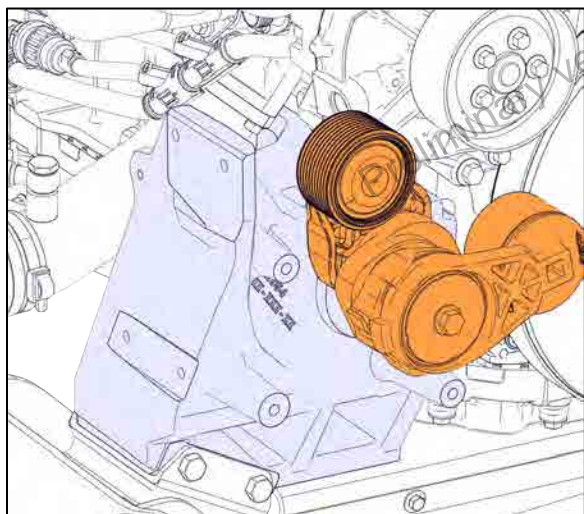

FIGURE 43:KEEP IDLER/TENSIONER ASSEMBLY INTACT



FIGURE 44: IDLER / TENSIONER ASSEMBLY MOUNTING SCREWS

- Support engine by the oil pan cover edge. Use wooden blocks under a bottle jack and a soft metal bar on the oil pan edge.

Do not apply upward tension on the engine. Simply support the engine to make sure it does not move down at engine mount removal.



FIGURE 45

- From under the engine, remove the cross-member bolts from the left engine mount.

Keep hardware.

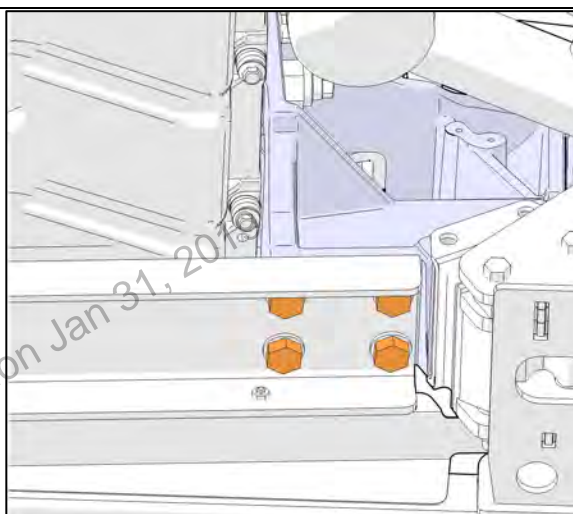

FIGURE 46

- Remove screws and stud from the engine.

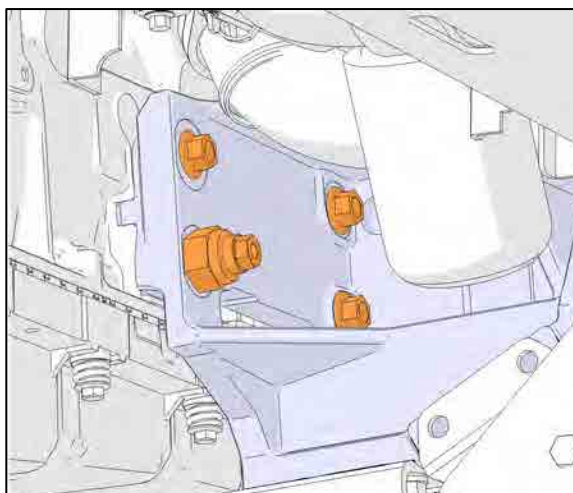

FIGURE 47

13. Remove isolator bolts.

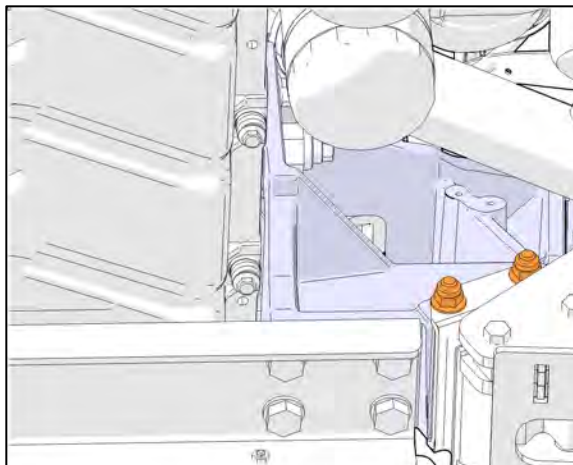

FIGURE 48

14. Remove engine mount

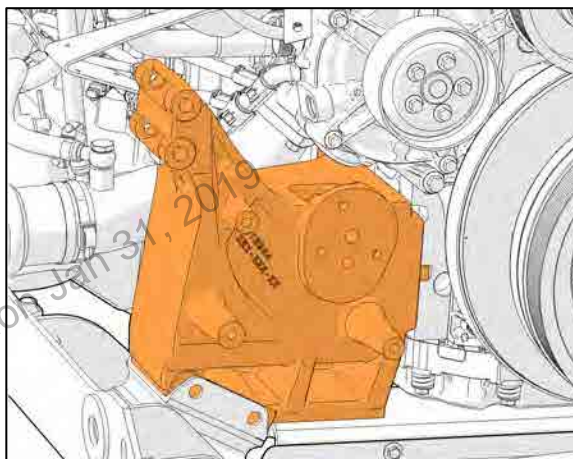

FIGURE 49

LEFT HAND ALTERNATOR INSTALLATION

15. Transfer tie mount and confirm cable support screw is on new engine mount 010090.



FIGURE 50

16. Cut the engine cradle rail as shown.

Carefully work the edge to achieve a smooth finish and contour.

Wear appropriate personal protection equipment.

Protect engine and area with blankets.

Blow area clean when completed.

Apply gravel guard compound on exposed metal.

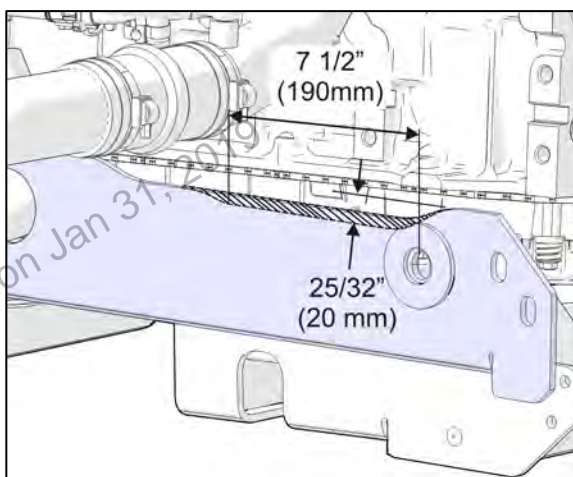

FIGURE 51

17. Cut sloped cable support below tie mount hole.

Keep the four (4) tie mounts.

Wear appropriate personal protection equipment.

Protect area with blankets.

Blow area clean when completed.

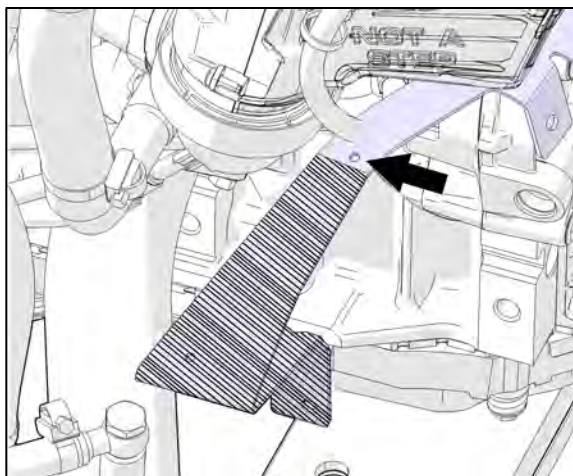

FIGURE 52

18. Re-install three of the four reserved tie mounts on the sloped support 061502 with 504379 rivets. Two under; one on top just next to the bend.

Leave the upper hole empty.

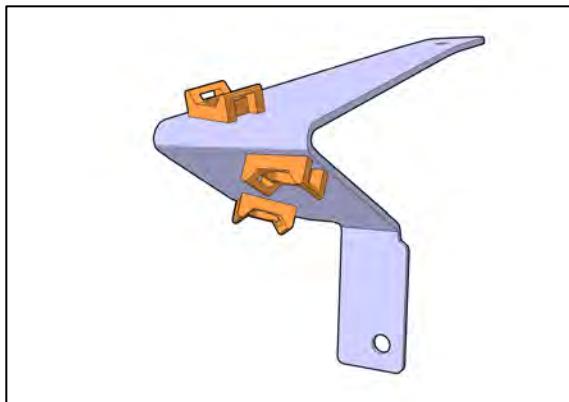

FIGURE 53

19. Install water pump idler / tensioner assembly on 010090 support.

Tighten to **17 lb-ft.**

Apply torque seal

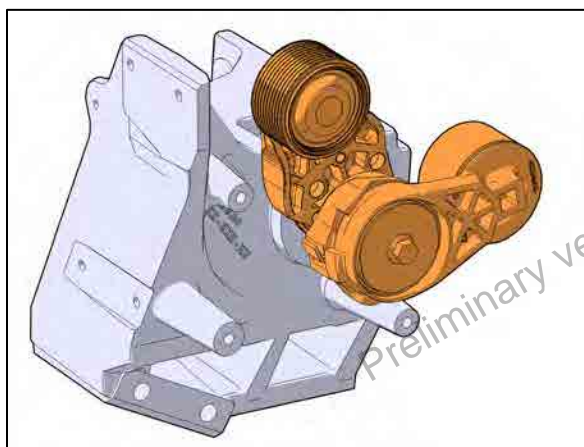

FIGURE 54: IDLER/TENSIONER ASSEMBLY

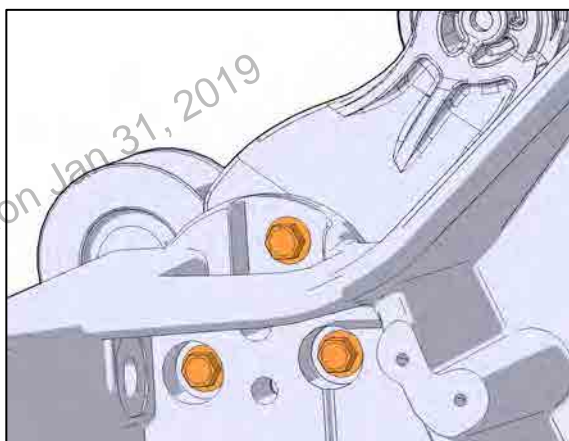

FIGURE 55

20. Position new engine mount 010090 with soft hammer and pry bar.

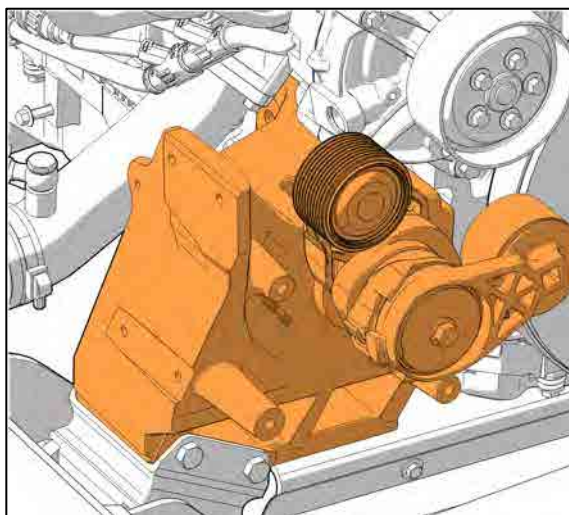

FIGURE 56

21. Tighten screws on the engine to **94 lb-ft.**

Tighten ground stud to **94 lb-ft**

Tighten stud nut to **183 lb-ft.**

Apply torque seal.

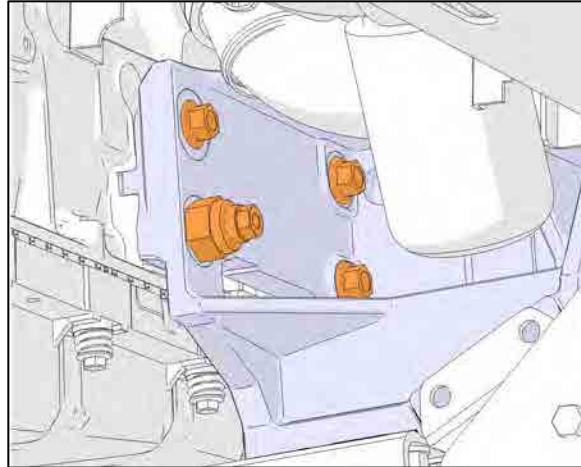

FIGURE 57

22. Tighten isolator screws to **60 lb-ft.**

Apply torque seal

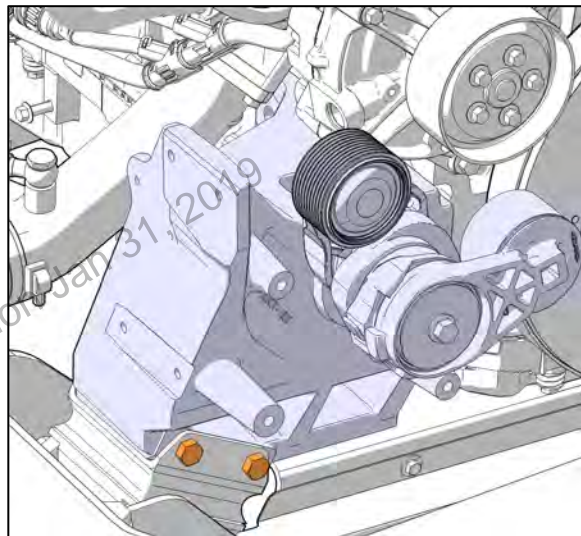

FIGURE 58

23. Reinstall water pump belt.

To do so, rotate the automatic belt tensioner using a $\frac{1}{2}$ square drive breaker bar.



FIGURE 59

-
24. Install alternator brackets 069890 and 069891 with four (4) 5001308 M10x40 bolts.

Note: Install the upper 069891 with short end towards bumper and long end towards turbo.

Apply blue Loctite 680038

Tighten to **48 lb-ft**

Apply torque seal

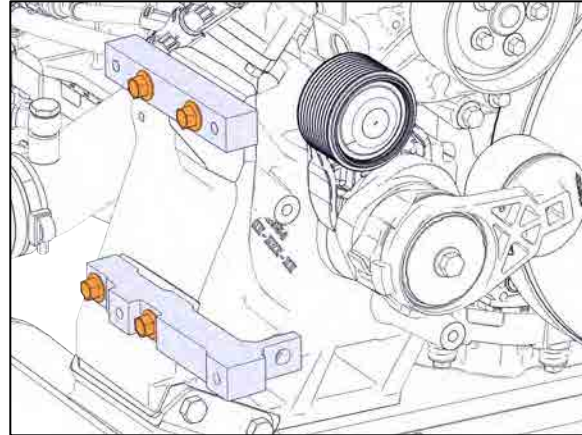

FIGURE 60

-
25. Install new sloped support 061502. Use tie mount and rivet 504379.

Secure lower end with cable support screw, apply blue loctite.

Tighten to 17lb-ft

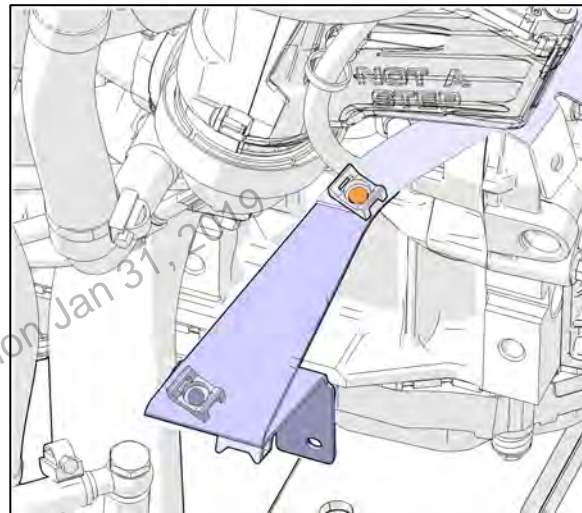

FIGURE 61

26. Installing the LH alternator pulley.

Place 560720 alternator flat on a bench with the shaft horizontal.

Required tools:

- 15-16" crowfoot adapter
- 8mm hex bit

Clean shaft and pulley with brake cleaner.

Slide pulley 069893 on shaft by hand.

Hand thread nut on shaft until snug.

Using thin wall 15/16" adapter and 8mm hex bit to block shaft rotation, tighten to **70-80 lb-ft.**

Apply torque seal

Never use power tools to install pulley and nut.

Note: Do not apply any pressure to end of the shaft. Internal damage may occur if the shaft is pushed back and turned.

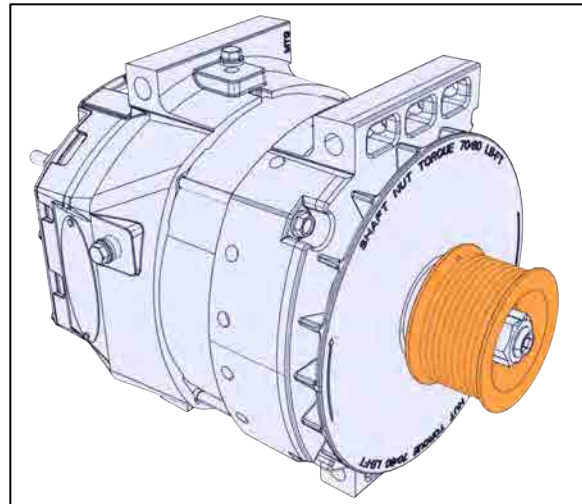

FIGURE 62

27. Install alternator on support with 5002091 M10x120 screw.

Apply blue Loctite 680038

Tighten to **48 lb-ft.**

Apply torque seal

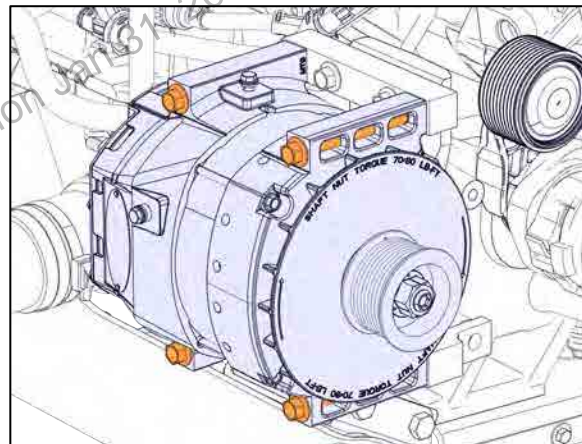

FIGURE 63

28. Re-install idler support.
Tighten to **48 lb-ft**

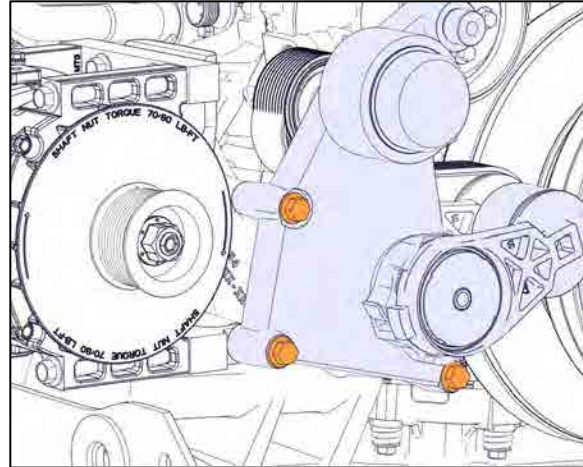

FIGURE 64

29. Install belt 506067.
To do so, rotate the automatic belt tensioner using a ½ square drive breaker bar.
30. Remove former belt routing decal and replace with decal 010111.

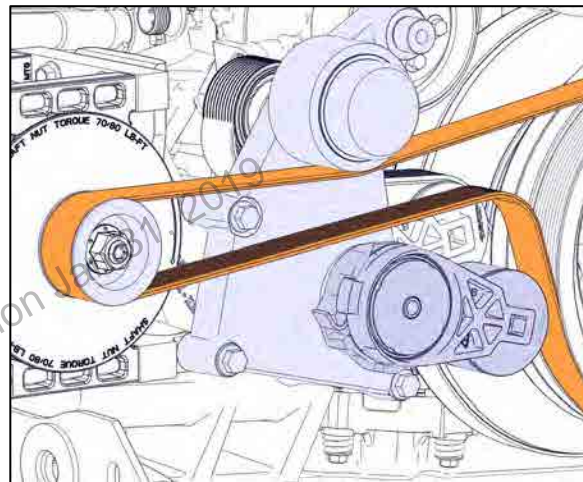

FIGURE 65

LEFT HAND ALTERNATOR CONNECTIONS X3-45

31. Install control harness 0610037 on alternator.
(Figure 2)

Use 5001180 10-24 Nylon lock nut and
5001137 washer.

Tighten to the following torque values:

Sense (S): **25-45 lb-in (3.0 5.0 N-m)**

Indicator (I): **25-45 lb-in (3.0 5.0 N-m)**

Apply color guard 684013 on connections.

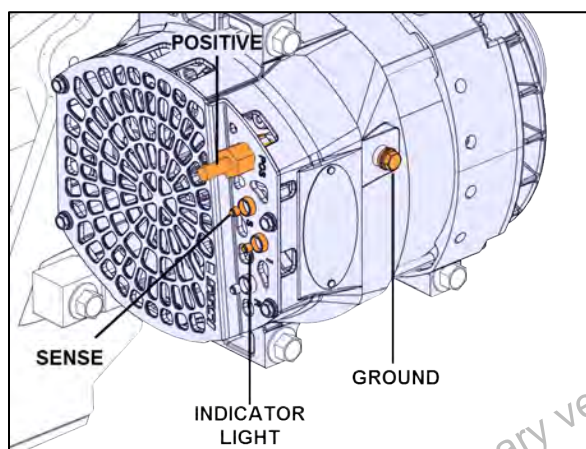

FIGURE 66

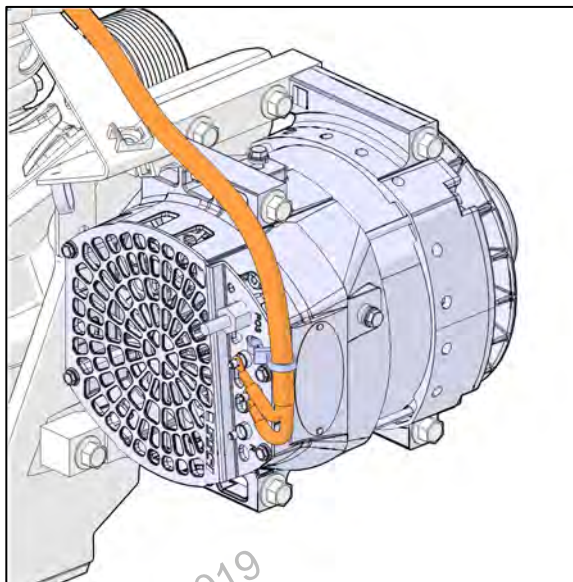

FIGURE 67

32. Route control harness up the sloped support
and back over the engine to C_ALT3
connector. (Figure 3)

33. Refer to ELECTRICAL SCHEMATICS;



FIGURE 68

34. Install ground cable 0610035 and power cable 0610031 on alternator.

Ground:

Add 500411 SS Washer.

Tighten to **50-60 lb-in (5.6-6.8 N-m)**

Positive:

Use 500685 Nylon lock nut and 5001341 SS Washer.

Tighten to **80-125 lb-in (9.0-14.0 N-m)**

Apply color guard 684013 on connections.

35. Connect ground cable to the engine grounding stud.

Tighten to **240 lb-in.**

Apply color guard 684013 on connections..

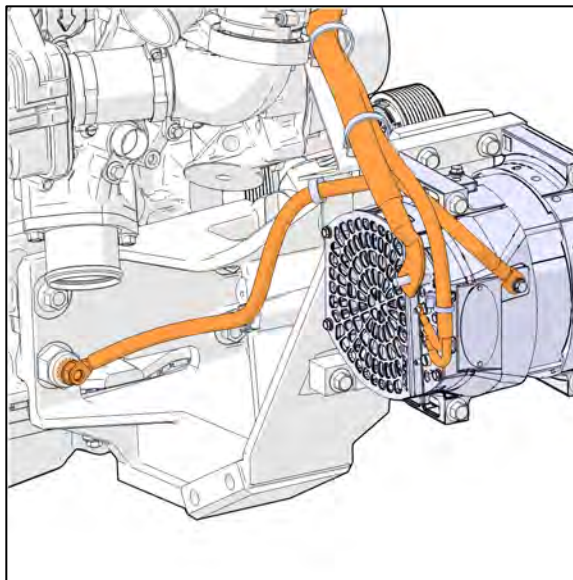

FIGURE 69

36. Route power cable up the sloped support, over the engine and back to the main power compartment. Connect to the 24V junction blocks.

Tighten to **96 lb-in.**

Apply torque seal.

Refer to ELECTRICAL SCHEMATICS;



FIGURE 70

BOOST REGULATOR INSTALLATION - X SERIES- EFD

37. In the main power compartment, create some working space by unplugging and removing the Allison transmission control module (TCM).

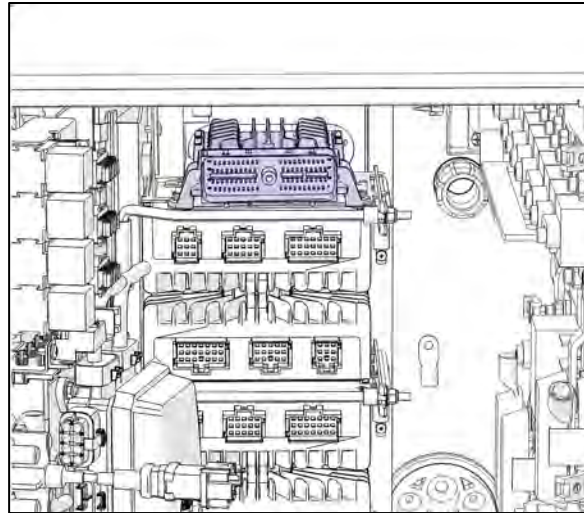

FIGURE 71

38. Place the boost regulator bracket 0610001 on the top shelf.
39. If there are no existing holes on the top shelf, drill new holes by using the bracket as a template. Drill 4mm (5/32") diameter holes.

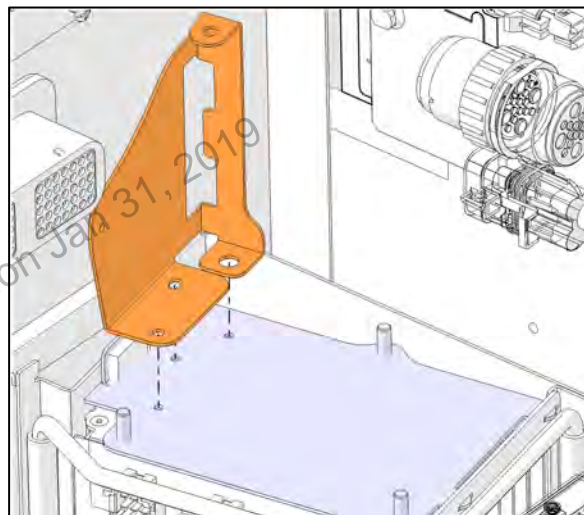

FIGURE 72

40. Install bracket 0610001 with 5001975 screws and 5001137 washers.

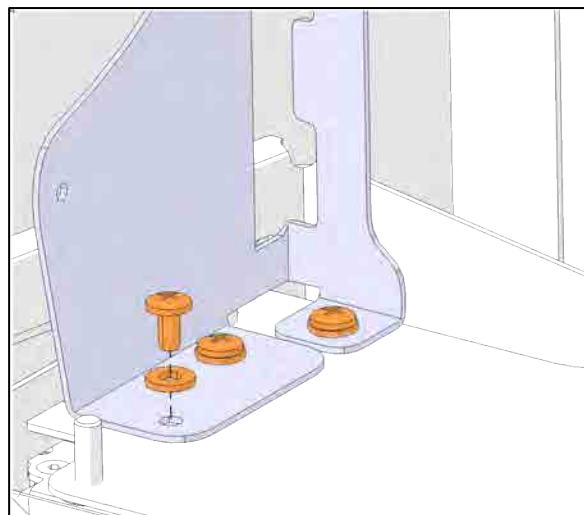

FIGURE 73

41. Install boost regulator 560629 on bracket with 5001975 screw.

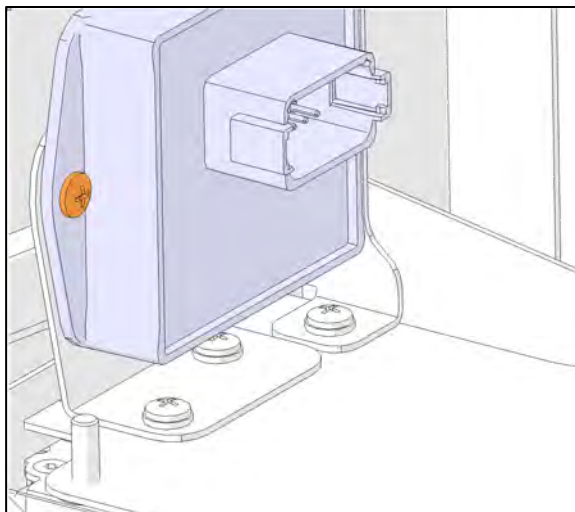

FIGURE 74

42. Plug connector C175 from harness 0610042 to boost regulator.

Preliminary version Jan 31, 2019

44. Before connecting the harness, locate the following components in the main electrical compartment

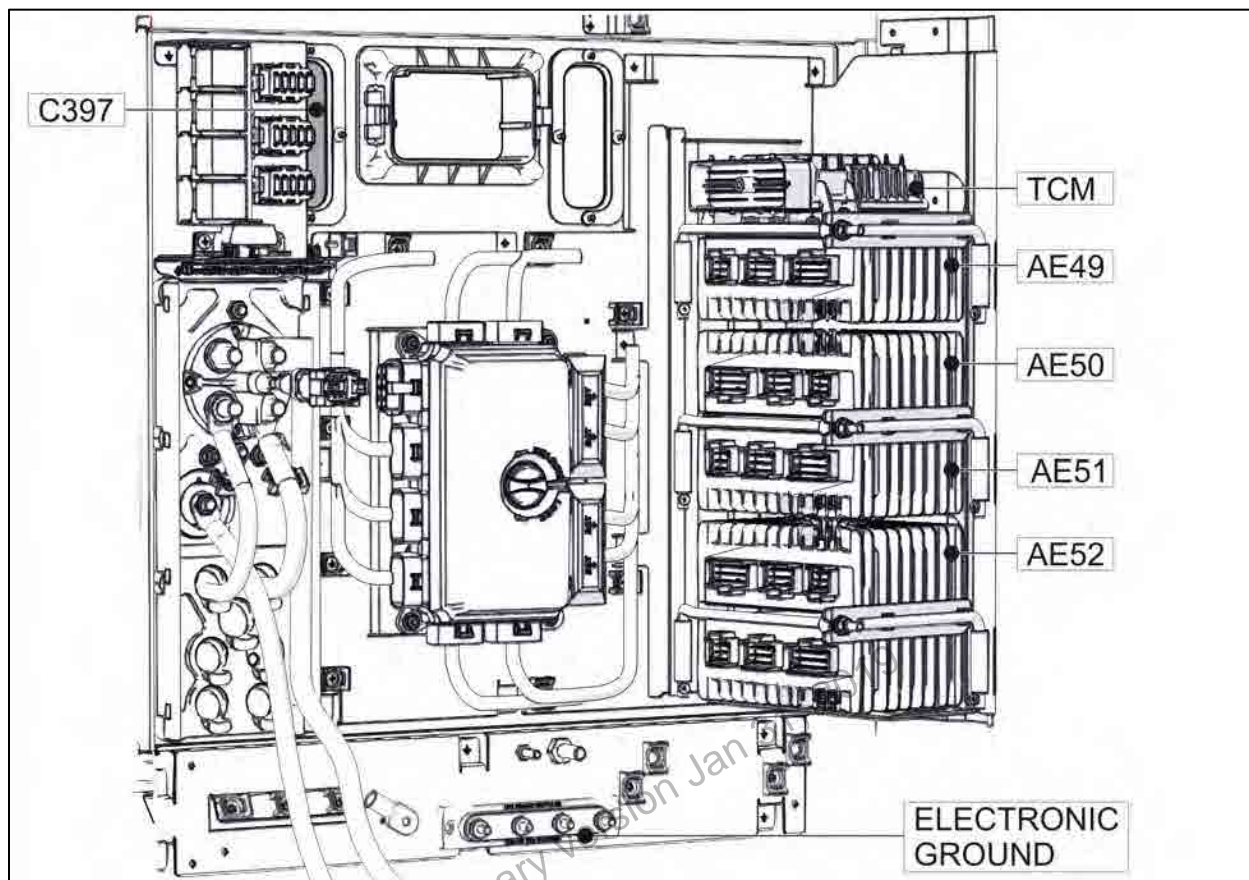

FIGURE 75

45. Connect 0610042 harness to the following locations in the main power compartment. Remove existing wire in the connector cavity at these locations and replace by terminal from the harness.

Refer to CONNECTOR PINOUT REFERENCE and Figure 3

Circuit	Device	Connector	Pin	Notes
A49J2.1	AE49	J2	1	568103 Extractor
A175J2.12	AE50	J2	8	568103 Extractor
A52J2.4	AE52	J2	4	568103 Extractor
A52J2.4	-	C397	4	682321 Extractor
A49J2.1	-	C397	67	682321 Extractor
F139	VECR	VECR4	D	682256 Extractor
00R	Electronic Ground	Term00R	Add to any stud	Tighten to 60 lb-in

46. **Note:** Seal removed wires. Cut terminal and seal with double wall EPS heat shrink

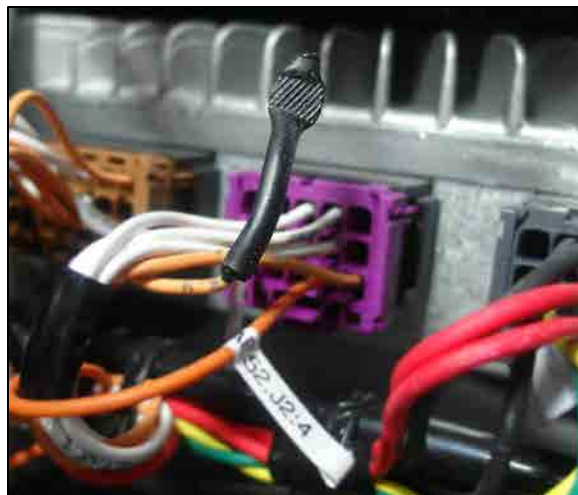

FIGURE 76

MULTIPLEX PROGRAMMING

47. In VPG, change value of parameter ALTTYP to 1. Generate program and transfer

FUNCTIONAL TESTING

48. Reset main circuit breakers if applicable. Set the battery master switch (master cut-out) to the ON position and start the engine. Make sure that the charging system is working normally.

On the instruments cluster, the alternator telltale  illuminates if the alternators are not charging.

APPENDIX A – LTD WIRE GUIDELINES

IMPORTANT: If the LTD wire is disturbed; the following guidelines must be followed to secure it properly.

NOTE

Always use double loop cable ties to secure LTD. LTD must be tied alone, with no other cables in the loop.

NOT ALLOWED



Possible contact or rubbing against screws, edges, etc.

CORRECT

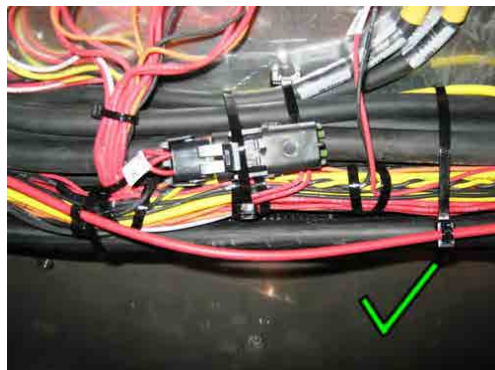

LTD must be routed clear of screws, sharp edges, etc.

NOT ALLOWED



Rubbing or possible rubbing against abrasive surfaces

CORRECT

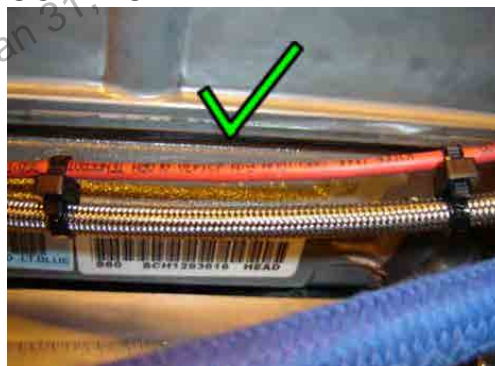

LTD must be secured with double loop cable ties. Distance between cable ties must not exceed 4 inches (100mm) max

NOT ALLOWED



LTD touching cut cable tie

NOT ALLOWED

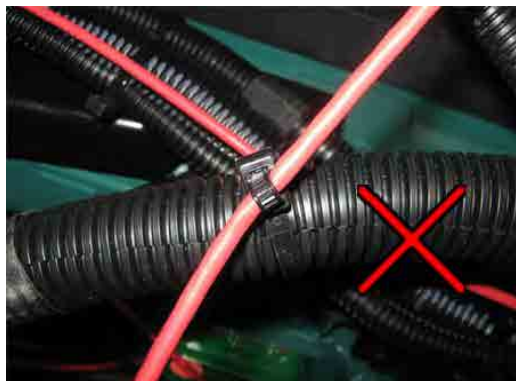

LTD extending slantingly from the cable tie

CORRECT



LTD is not a flexible harness. Avoid tight bends and kinks which could short circuit the LTD. Loops must have a minimum radii of 4 inches (100 mm)

NOT ALLOWED



Cable tie tighten in excess on the LTD. Tighten cable tie on LTD by hand only. Tighten just enough to prevent LTD from slipping from once side to the other inside the cable tie loop

CORRECT

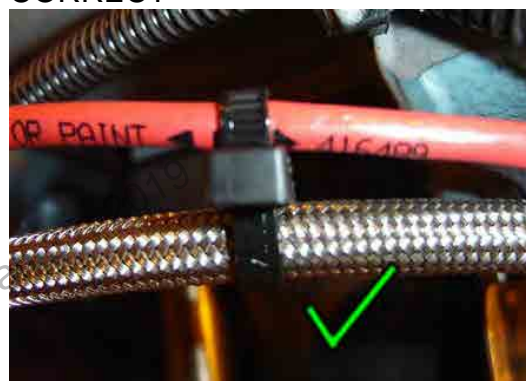

Proper tightening of the cable tie on the LTD

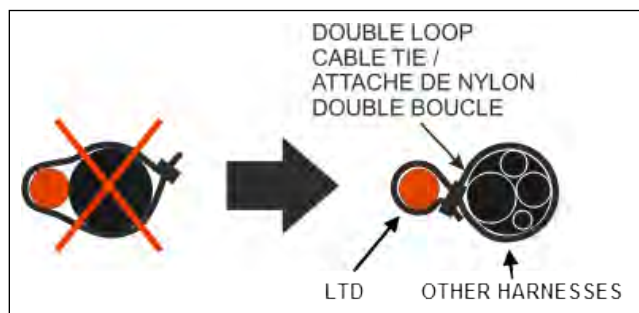

LABOR REFERENCE TABLE

Table for reference only.

Actual times will vary depending on vehicle condition.

	<i>Operation</i>	<i>Approximate labor (hours)</i>
Step 1	BOSCH ALTERNATORS REMOVAL, RIGHT HAND SIDE	1h
Step 2	INSTALLING THE RIGHT HAND ALTERNATOR. (includes wiring)	2h
Step 3	BOSCH ALTERNATORS REMOVAL, LEFT HAND SIDE	1h
Step 4	INSTALLING THE LEFT HAND ALTERNATOR. (includes wiring, cradle and cable support modifications)	2.5h
Step 5	BOOST REGULATOR INSTALLATION	1.5h
Step 6	MULTIPLEX PROGRAMMING.	0.5h
Step 7	FUNCTIONAL TESTING	0.5h
	Total	9 hours

PARTS / WASTE DISPOSAL

Discard waste according to applicable environmental regulations (Municipal/State[Prov.]/ Federal)