

# PREVOST

## Instruction Sheet

## IS-18909







### CARRIER TO BITZER AC COMPRESSOR RETROFIT

#### MATERIAL

Order kit # IS18909 that contains the following parts:

Part No.	Description	Qty	
7770442	COMPRESSOR SPECIAL SUPPORT	1	
630062	RUBBER BUSHING	2	
950494	BITZER COMPRESSOR	1	
067349	TOP WIRE SUPPORT	1	
950539	AC CLUTCH ASSEMBLY	1	
5001775	CAP SCREW HEXS G500 M8-1.25X25 G12.9	4	
506864	BELT-V BX100 (SET OF TWO)	1	
950521	KIT UNLOADER	1	
950493	HIGH SIDE HOSE	1	
950489	LOW SIDE HOSE	1	
501802	O'RING #16	1	
501803	O'RING #20	1	
950957	GASKET	2	
N31320-07	CLAMP LOOP TYPE	2	
474304	BOLT 1/4-20	1	
500411	WASHER ¼	2	
5001123	NUT 1/4-20	1	
950504	TRANSDUCER	2	
950030	SHRADER VALVE	3	

950498	HIGH PRESSURE SWITCH	1	
950500	ADAPTOR 7/16-20 X R134A HI-PRESS	1	
950499	ADAPTOR 7/16-20 X R134A 13MM	1	
5001338	SCREW M12X45LG	4	
500967	WASHER BEL 1/2	4	
500811	NUT STO 1/2	4	
500197	SCREW 3/8X1LG	2	
500265	NUT STO 3/8	2	
500832	FT WASHER 0.41 ID	2	
500086	SCREW1/2X1.5LG	2	
500718	NUT STO 1/2-20	2	
500211	FLAT WASHER 1/2 ID	2	
564127	CONNECTOR, TYPE JUNIOR POWER TIMER	1	
562853	TERMINAL, SOCKET AMP	2	
563137	CABLE SEAL, (1.20-2.10) JPT - BLUE	2	
561690	CONNECTOR SOCKET 2C(WP)	1	
561578	SOCKET, FEMALE TERMINAL	2	
561565	CABLE SEAL, PED CONN. - GREEN (20-18 GA)	2	
560190	WIRE, 16 AWG, GXL, WHITE, 125 DEG	3	
563292	WIRE, 16 AWG, GXL, ORANGE, 125 DEG	6	
560786	SHRINK TUBING .5-.25ID BLACK	0.5	
560673	WIRE, 16 AWG, GXL, BLK, 125 DEG	4	

562228	BUTT SPLICE 16-14	6	
560784	SHRINK TUBING .25-.08ID BLACK	0.5	
562387	CONVOLUTED TUBING .25 ID BLACK SLT	5	
509815	FIR TREE MOUNTING (FT7 TYPE)	4	
504013	CABLE TIE MOUNT MIDDLE SIZE	4	
504810	CABLE TIE MOUNT SMALL SIZE	2	
504016	CABLE TIE, NYLON BLK (LIGHT-HEAVY)	14	
562470	RESISTOR 1000 OHMS 2 W	1	
562806	TERMINAL, SOCKET AMP (JPT) (20-18)	1	
562499	SHRINK TUBING CLEAR	0.5	
560815	RING TERMINAL #10 RED (22-18)	1	
069481	BOTTOM WIRE SUPPORT	1	
069450	MIDDLE WIRE SUPPORT	1	
504379	POP RIVET DOME SS OE 3/16X1/4	4	
504340	POP RIVET DOME SS OE 1/8X3/16	2	
950332	FILTER DRYER	1	

Other parts that may be required:

Part No.	Description	Qty
680038	LOCTITE 243 BLUE	AS REQ.

**NOTE**

Material can be obtained through regular channels.

**NOTE**

This bulletin only applies to the replacement of the Carrier AC compressor by a Bitzer compressor. Any other AC system problems should be treated separately.

### **IMPORTANT NOTE**

Anyone who maintains, services, or repairs motor vehicle air conditioners for of any kind must be properly certified. Check the regulation applicable and make sure that the technician is certified before proceeding with this bulletin.

## **PROCEDURE**



### **DANGER**

Park vehicle safely, apply parking brake, stop the engine. Prior to working on the vehicle, set the ignition switch to the OFF position and trip the main circuit breakers equipped with a trip button.

## **REFRIGERANT REMOVAL**

1. Locate the evaporator compartment (Figure 1).

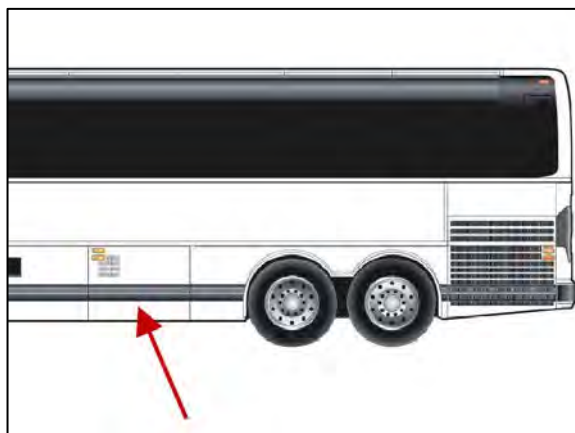

**FIGURE 1**

2. Into the evaporator compartment, locate the C24 pin connector with the plug and the C24 socket connector with the plug.
3. Remove the plug on both connectors and keep it in a safe place (Figure 2).
4. Connect the C24 pin connector with the C24 socket connector.



**FIGURE 2**

5. Locate the front service compartment (Figure 3).

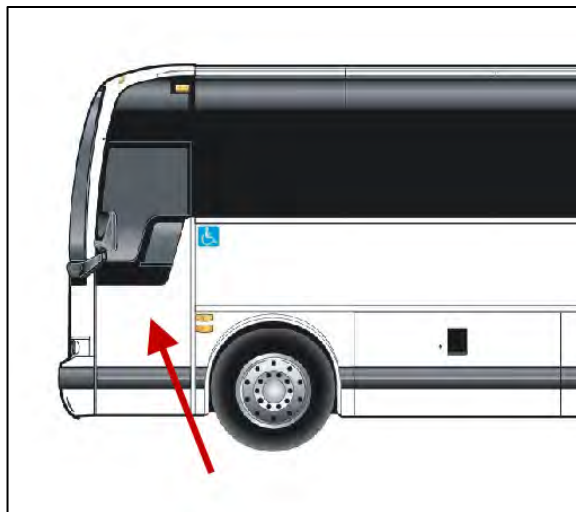

FIGURE 3

6. Into the front service compartment, locate the C44 pin connector with the plug and the C44 socket connector with the plug.
7. Remove the plug on both connectors and keep it in a safe place (Figure 4).
8. Connect the C44 pin connector with the C44 socket connector.



FIGURE 4

9. Remove all refrigerant (ref. PR10188-83 and PR10114-271).
10. From the evaporator compartment, remove filter dryer and discard it.

## CARRIER AC COMPRESSOR REMOVAL

11. Locate belt tensioner air pressure valve on the upper right corner into the engine compartment.
12. Rotate the lever to release belt tensioner air pressure.



FIGURE 5

13. Disconnect high and low pressure hoses on the existing compressor.



FIGURE 6

14. Disconnect high and low pressure hoses to the AC system tubes.
15. Discard the hoses.



FIGURE 7

16. Cut all cable ties that secure the existing compressor wirings and connectors.
17. Locate connector L199 (Unloader RH).
18. Cut orange existing orange wire (#31) and existing black wire (#0RA4) flush to the L199 connector. Keep label L199 on the wire.

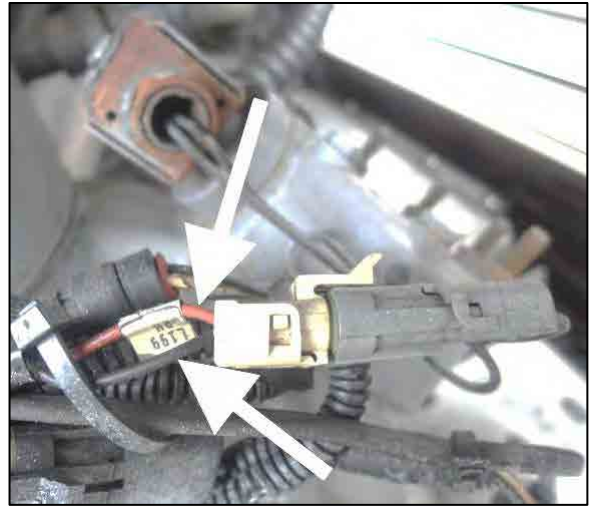

**FIGURE 8**

19. Locate connector L200 (Unloader LH).
20. Cut existing orange wire (#33) flush to the L200 connector.

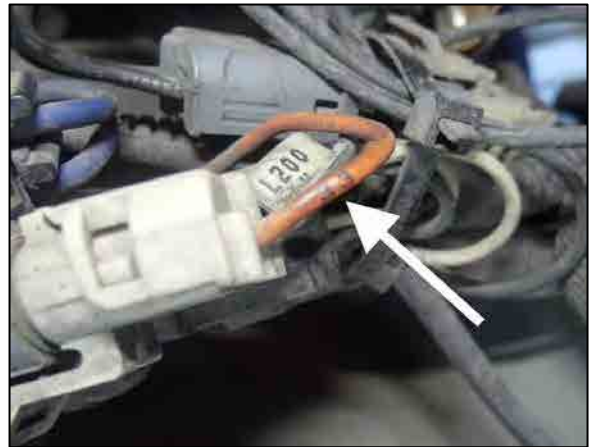

**FIGURE 9**

21. Install 2" of black shrink tubing on the existing orange wire #33 and heat it to make it watertight.
22. Disconnect all remaining wire connectors on the existing compressor.



**FIGURE 10**

23. Remove screws on the curb side.



FIGURE 11

24. Remove screws on the engine side.

25. Discard existing AC compressor and existing fasteners.



FIGURE 12

## MOUNTING THE CLUTCH ON THE COMPRESSOR

26. Before installing the clutch, dismount the oil tube on the left side of the shaft. The tube is installed on the opposite side. Keep the support and the fasteners.



FIGURE 13

27. The flange and the shaft end must be free from dirt.
28. Apply high temperature approved assembly grease on the shaft end for easy dismounting of the clutch. Use of Molykote G-rapid-plus or Molykote P 40 is recommended.



FIGURE 14

29. Install the coil. Slip the coil on the compressor flange. The cable connector must be positioned on the right side as shown in Figure 15.



FIGURE 15

30. Fix the coil with 4 screws PN 5001775. Use Loctite 243 blue on each screw.
31. Torque the screws to a value of 20-24 lb-ft.

 **CAUTION**

Pay attention to the precise seat of the coil. A non-observance may cause the destruction of the clutch components during the operation.



FIGURE 16

32. To avoid damaging the rotor bore, make sure that the woodruff key supplied with the clutch is positioned as shown in Figure 17, otherwise, it could move when the rotor is inserted on the shaft end.



FIGURE 17

33. Carefully mount the rotor on the shaft end by hand. Never use a hammer for pressing the rotor on.

**NOTE**

*To avoid damaging the bore of the rotor, feel the engagement of the key in the keyway and slip the rotor on the shaft end of the compressor till reaching the stop.*



FIGURE 18

34. Fasten the rotor to the shaft end by using the M12 screw supplied with the clutch and holding-up with a wrench on the hexagonal part of the rotor. Apply blue Loctite 243 on the screw.
35. Tighten the screw to a torque value of 60 lbf-ft (81 Nm).

**NOTE**

*Turn rotor by hand and pay attention to the free run and the generation of noises. In case of rubbing, grinding or similar noises, dismount the rotor and check installation.*



FIGURE 19

36. Once properly tighten, apply a torque seal mark.



FIGURE 20

37. During cleaning or other work on the compressor, the clutch must be covered to prevent the penetration of greasy liquids, grease or dirt particles in the working gap of the clutch. No high pressure cleaning.

**NOTE**

*Working gap must be between these values:  
0.024 in - 0.035 in (0.60 mm - 0.90 mm)*

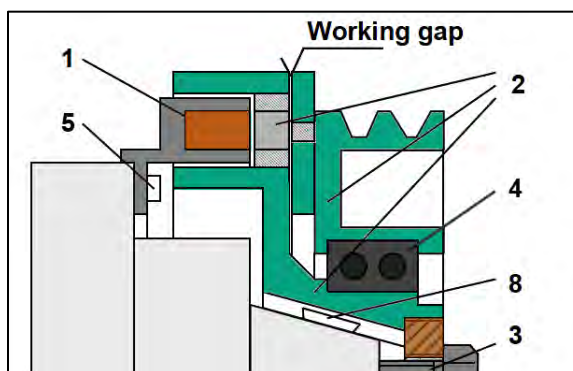
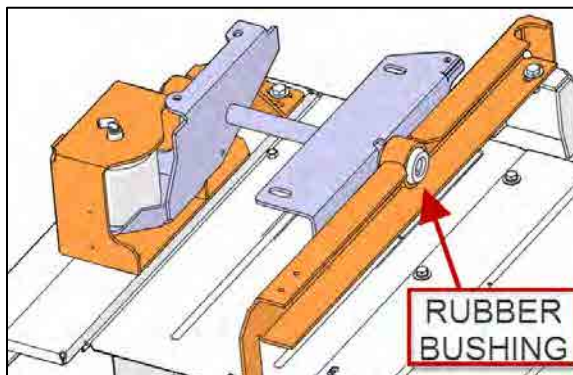

FIGURE 21

## BITZER AC COMPRESSOR INSTALLATION

38. If necessary, replace rubber bushings PN 630062.



**FIGURE 22**

39. Install cable tie mount on the bottom wire support. Use table below for the components.

069481	BOTTOM WIRE SUPPORT	1
504340	POP RIVET 1/8"	1
504810	CABLE TIE MOUNT SMALL SIZE	1

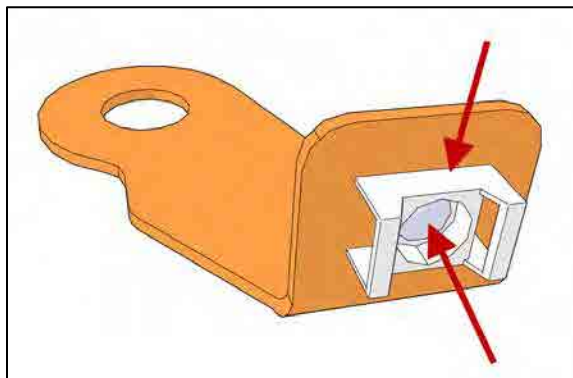

**FIGURE 23**

40. Install cable tie mount on the middle wire support. Use table below for the components.

069450	MIDDLE WIRE SUPPORT	1
504340	POP RIVET 1/8"	1
504810	CABLE TIE MOUNT SMALL SIZE	1

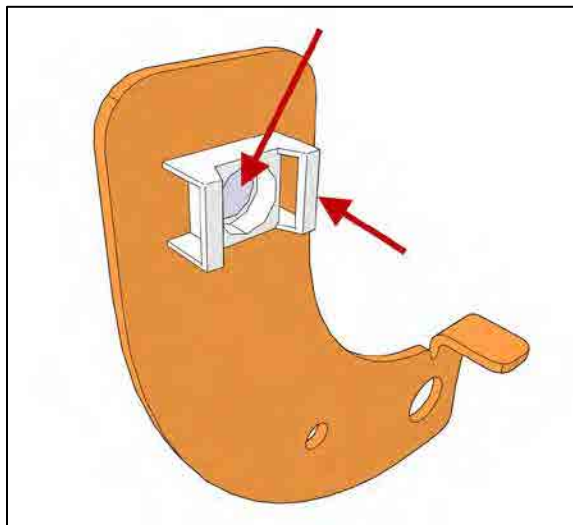

**FIGURE 24**

41. Install cable tie mounts and fir tree mounting on the top wire support. Use table below for the components.

067349	TOP WIRE SUPPORT	1
504379	POP RIVET 3/16X1/4	2
504013	CABLE TIE MOUNT BLACK 1/4"	2
509815	FIR TREE MOUNTING (FT7)	2

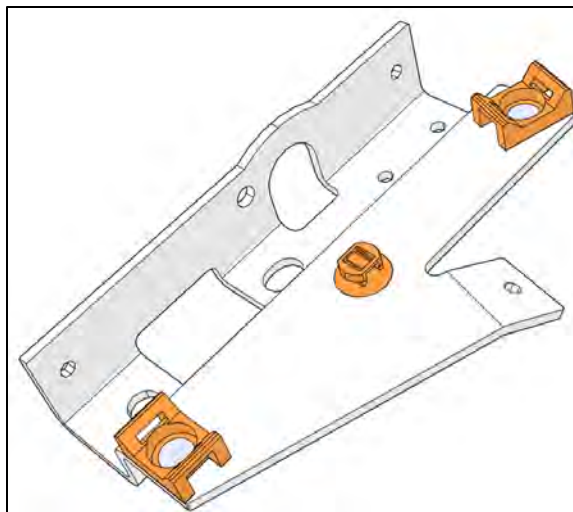

FIGURE 25

42. Prepare Carrier to Bitzer special support (PN 7770442) for installation.



FIGURE 26

43. Install special support (PN 7770442) on the existing compressor support with two screws on the pulley side. Use table below for components.

500197	SCREW 3/8X1LG	2
500265	NUT STO 3/8	2
500832	FT WASHER 0.41 ID	2

44. Do not tighten the screws.



FIGURE 27

45. Complete installation of the special support (PN 7770442) on the existing compressor support with two screws on the back side. Use table below for components.

500086	SCREW 1/2X1.5LG	2
500718	NUT STO 1/2-20	2
500211	FLAT WASHER 1/2 ID	2

46. Do not tighten the screws.



FIGURE 28

47. Install new compressor on the special support. Prepare to install the bottom wire support with the screw on the pulley side.

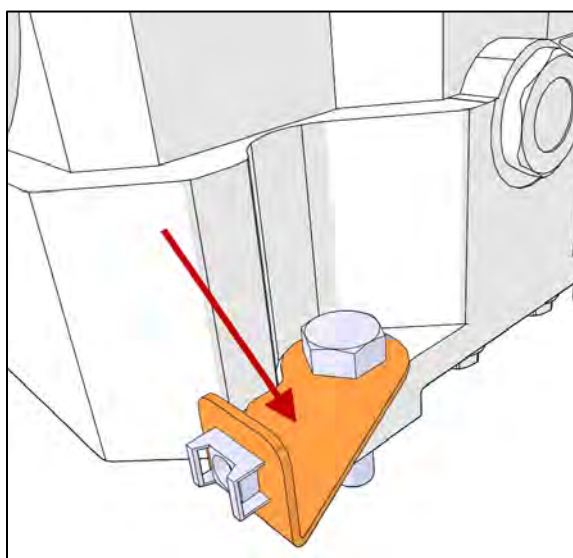

FIGURE 29

48. Install new compressor on the special support with 4 screws. Use table below for the components.

5001338	SCREW M12X45LG	4
500967	WASHER BEL 1/2	4
500811	NUT STO 1/2	4

49. Torque the screws to a value of 74 lb-ft.

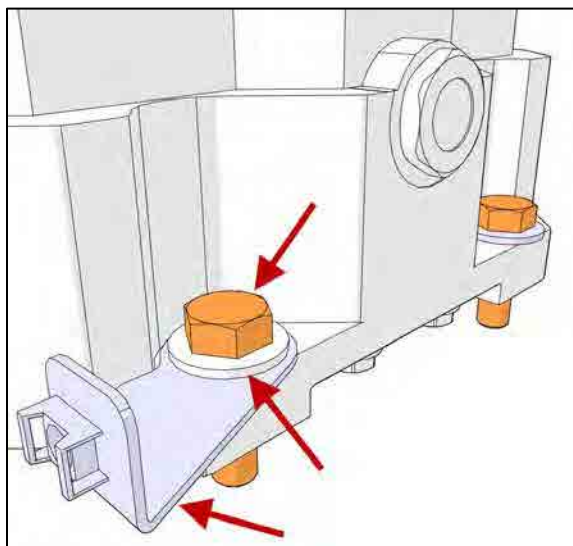

FIGURE 30

50. Check alignment between engine pulley and compressor pulley.
51. Use an electronic level for the vertical alignment and install shim if necessary.
52. Use a rule for the horizontal alignment. Compressor support has arced slot to facilitate the horizontal alignment.
53. Tighten the screws (4) that hold the special support with the existing compressor support.



FIGURE 31

54. Clean the hose fittings and the new O'Rings.
55. Lubricate both O-Rings with compatible 134-A AC oil before installation on the fittings.
56. Install new O'Ring on the new hose fittings.



FIGURE 32

57. Connect new high-pressure hose and new low-pressure hose to the AC system tubes. Use table below for components.

950493	HIGH-PRESSURE HOSE	1
950489	LOW-PRESSURE HOSE	1
501802	O'RING #16	1
501803	O'RING #20	1

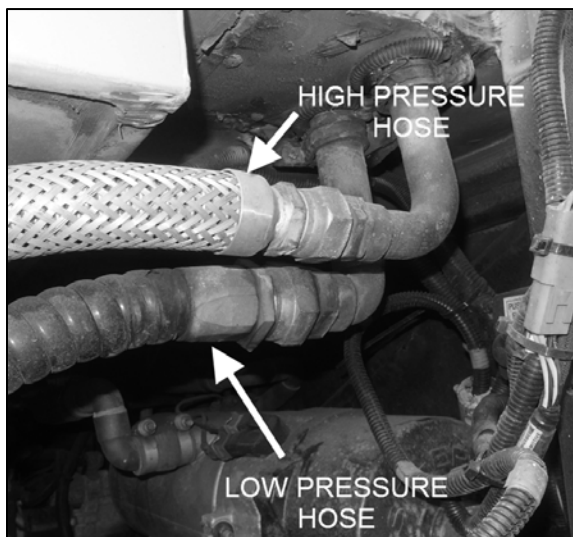

FIGURE 33

58. Add seal marks on both fittings.



FIGURE 34

- 59. Clean hose mounting faces (new compressor and new hose flanges).
- 60. Connect high pressure hose and low-pressure hose to the AC compressor.
- 61. Use new gasket PN 950957 on both flanges
- 62. Torque flange screws to 31-35 lb-ft (42-47 Nm).
- 63. Add torque seal marks on all flange screws.

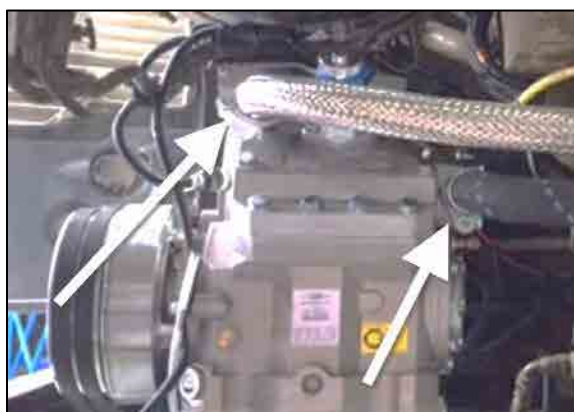

FIGURE 35

- 64. Install hose clamps around the mid-distance of the hoses as shown in Figure 36. Use table below for components.
- 65. Make sure to keep a clearance between the hoses and the side door.

N31320-07	CLAMP LOOP TYPE	2
474304	BOLT 1/4-20	1
500411	WASHER 1/4	2
5001123	NUT 1/4-20	1

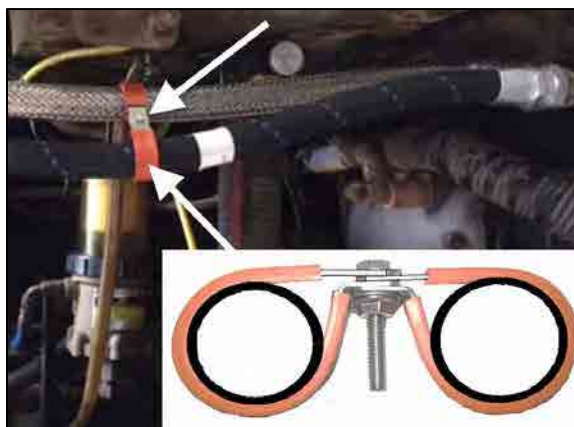

FIGURE 36

66. Install Kit Unloader (PN 950521).

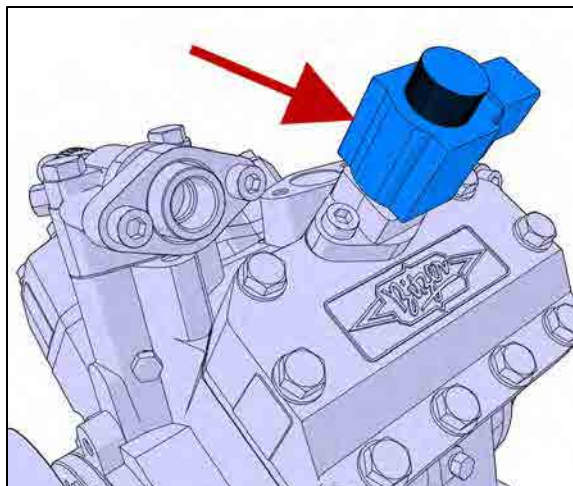

FIGURE 37

67. Install top wire support (PN 067349). Use compressor screws (2).

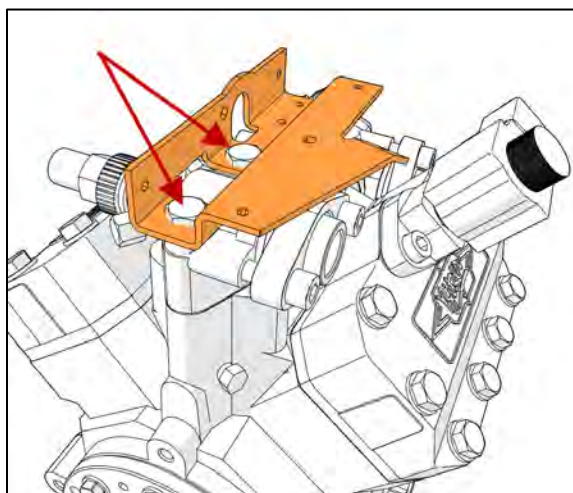

FIGURE 38

68. Install all components (5) shown in Figure 39 on the new compressor.

69. Connect existing connector Se23 (High) and existing connector Se24 (Low) to the transducers as shown in Figure 39.



FIGURE 39

70. Install all components (3) shown in Figure 40 on the new compressor.
71. Connect the other end of PN 950498 to the existing connector Se29.

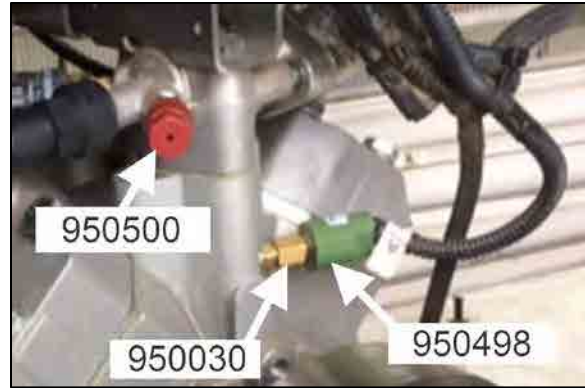

**FIGURE 40**

## MAKING OF WIRING A

72. Prepare material for wiring A.



FIGURE 41



FIGURE 42

- 73. Cut white and orange wire 36" long each.
- 74. Install seals on wires as shown in Figure 43.
- 75. Install terminals as shown in Figure 43, crimp and solder it.

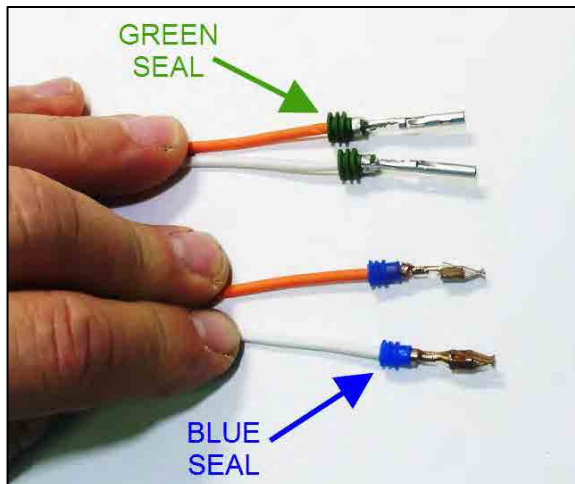

FIGURE 43

- 76. Install convoluted tubing (PN 562387) on the wires as shown in Figure 44.



FIGURE 44

- 77. Wrap the convoluted tubing and the wires together with electrical black tape as shown in Figure 45.
- 78. Insert orange wire terminal into pin A of connector PN 561690.
- 79. Insert white wire terminal into pin B of connector PN 561690.
- 80. Make sure the terminals are locked and the seals are positioned into the connector.
- 81. Lock the connector pivot.

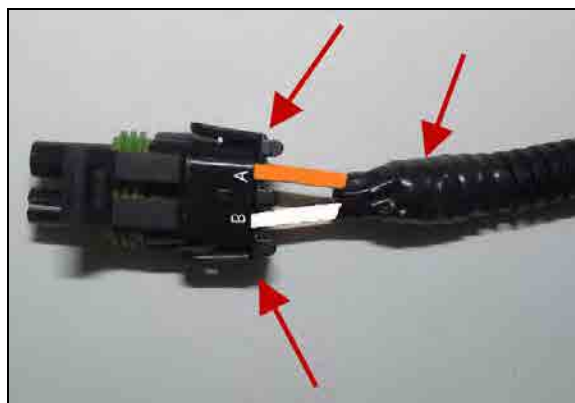

FIGURE 45

82. Use a P-Touch printer and make labels So9, 77BA and 78.
83. Attach label So9 (connector ID) on the harness as shown in Figure 46.
84. Attach label 77BA on the orange wire as shown in Figure 46.
85. Attach label 78 on the white wire as shown in Figure 46.
86. Connect new connector So9 to the existing connector So9.

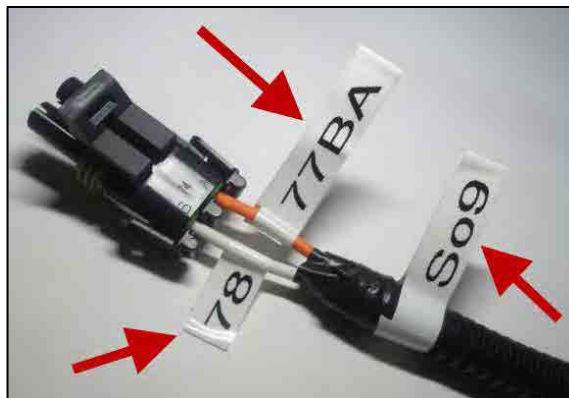

FIGURE 46

87. Slide 1.5" of shrink tubing (PN 560786) at the other end of the harness.



FIGURE 47

88. Insert orange wire terminal into pin 1 of connector PN 564127.
89. Insert white wire terminal into pin 2 of connector PN 564127.
90. Make sure the locking tabs on the terminals are oriented with the connector as shown in Figure 48.
91. Make sure the terminals are locked and the seals are positioned into the connector.

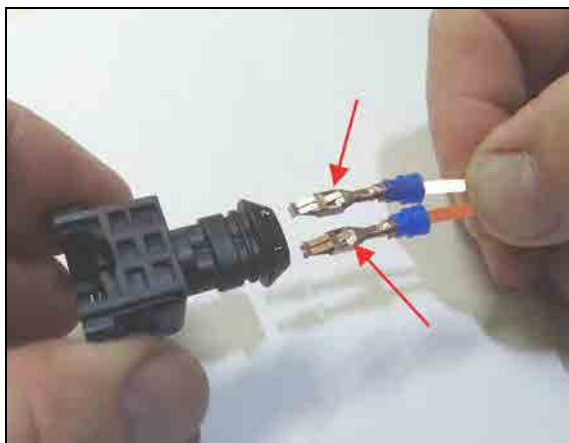

FIGURE 48

92. Move the shrink tubing over the connector to cover the whole connector neck.



FIGURE 49

93. Heat the whole shrink tubing and before it cools down, shape an elbow just from the connector neck as shown in Figure 50.
94. Use a P-Touch printer and make label So9b.
95. Attach label So9b (connector ID) to the harness as shown in Figure 50.
96. Connect connector So9b to the clutch magnet connector.



**FIGURE 50**

## MAKING OF WIRING B

97. Unplug connector from the Unloader valve.
98. Remove seal and connector core with a small flat screw driver.



FIGURE 51

99. Cut 24" of orange wire and 24" of black wire.
100. Run the wires through the connector components as shown in Figure 52.
101. Fix orange wire with screw #1 of the connector core.
102. Fix black wire with screw #2 of the connector core.

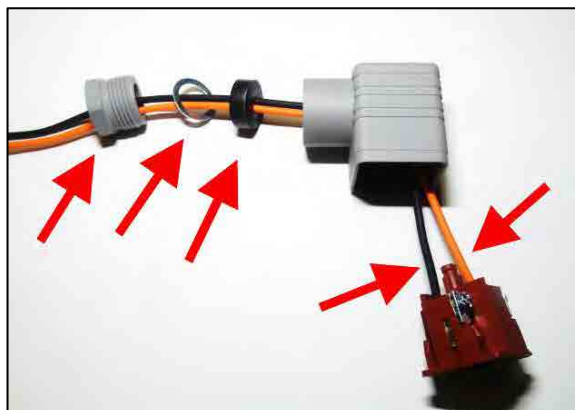

FIGURE 52

103. Install seal, flat washer and threaded collar. Tighten only with your hand.
104. Install the square seal.
105. Install 14" of convoluted tubing (PN 562387).



FIGURE 53

106. Wrap the wiring with hockey tape as shown in Figure 54.



FIGURE 54

107. Use a P-Touch printer and make labels L199, ORA2 and 31.
108. Attach label L199 (connector ID) to the harness as shown in Figure 55.
109. Attach label ORA2 to the black wire as shown in Figure 55.
110. Attach label 31 to the orange wire as shown in Figure 55.
111. Connect connector L199 to the Unloader valve.
112. Insert black shrink tubing into the new wire 31 and splice this wire with the existing wire 31 (see step 18). Clamp and solder the connection. Heat the shrink tubing to make it watertight.
113. Insert black shrink tubing into the new wire ORA2 and splice this wire with the existing wire ORA2 (see step 18). Clamp and solder the connection. Heat the shrink tubing to make it watertight.



FIGURE 55

## MAKING AND INSTALLATION OF WIRE C

114. Prepare components for wire C.

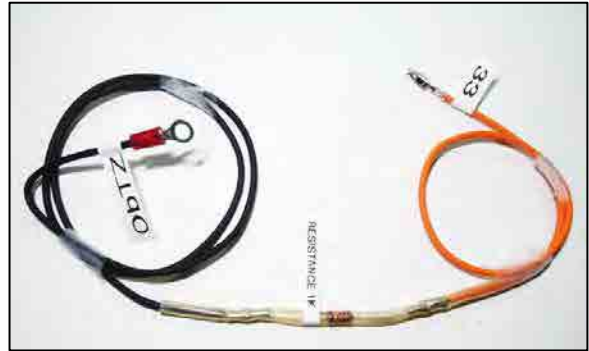

FIGURE 56



FIGURE 57

115. Cut 12" of orange wire.
116. Cut 24" of black wire.
117. Connect resistance with wires using two splices.
118. Clamp and solder both connections.

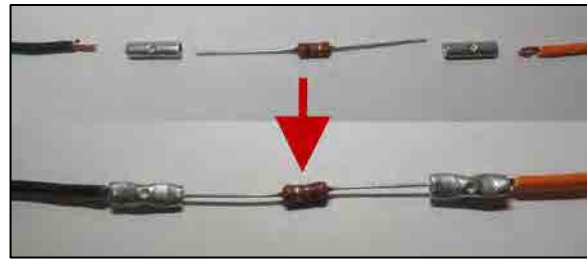

FIGURE 58

119. Install 6" of clear shrink tubing on the wire.
120. Heat the shrink tubing to lock it in place.



FIGURE 59

121. Install ring terminal on the black wire and socket terminal on the orange wire.
122. Clamp and solder both connections.



FIGURE 60

123. Use a P-Touch printer and make labels ObTZ, 33 and RESISTANCE 1K.
124. Attach label ObTZ on black wire.
125. Attach label 33 on the orange wire.
126. Attach label RESISTANCE 1K close to the resistance.

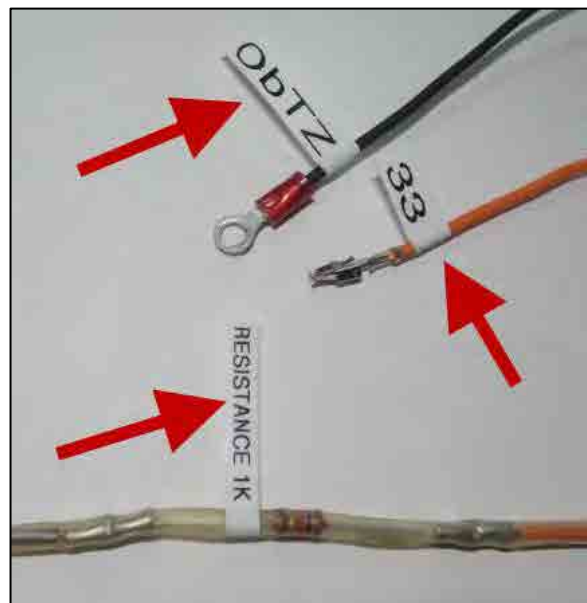

FIGURE 61

127. Locate A52 module into the rear junction box and existing orange wire #33 in pin J1:8.

128. Insert extractor (PN 683594) on the front of the connector. Remove the terminal by disengaging the flexible lock on the terminal. Gently remove the terminal from the connector by pulling on the wire.

129. Cut the terminal on the existing wire 33. Install 2" of black shrink tubing and heat it.



FIGURE 62



FIGURE 63

130. Connect new wire #33 (orange) into pin J1:8 of A52 module.

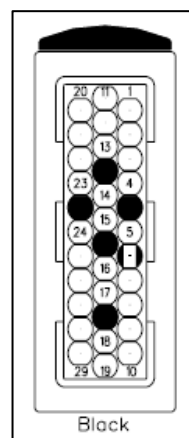

FIGURE 64

131. Connect black wire #ObTZ to the ground stud.

132. Secure all wires with cable ties.



FIGURE 65

## COMPLETE THE INSTALLATION

133. Use cable a tie to secure the clutch wiring with the bottom support. Make a loop at the bottom of the wiring.



FIGURE 66

134. Install the middle support with the oil tube support (reference step 26).

135. Use cable tie to secure the clutch wiring with the middle support.

136. Use cable ties to secure all the remaining wiring with the top support.



FIGURE 67

137. Install filter dryer (PN 950332) with new O'ring.

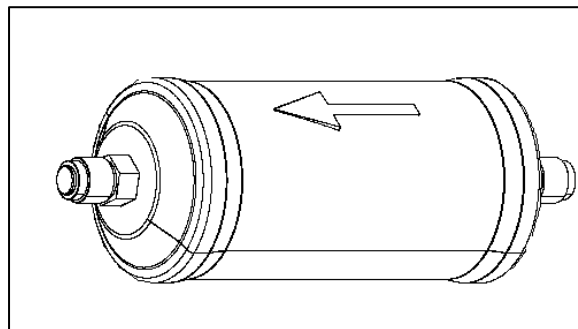

FIGURE 68

138. Install new belt (PN 506864).



FIGURE 69

139. Reset belt tensioner pressure releasing valve to 45 psi (310 kPa) to apply tension on the new belt.

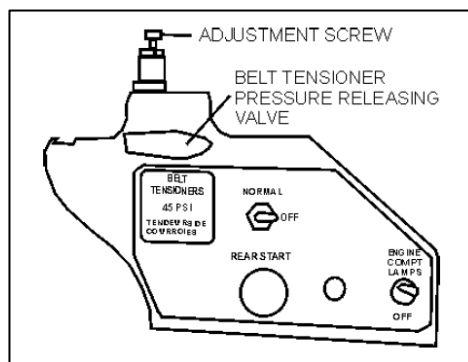

FIGURE 70

140. Perform a pressure test on the AC system and check leaking (ref. PR10114-212). If apply, fix the leaking.

**NOTE**

This bulletin only applies to the AC compressor replacement. Any other AC system problems should be treated separately.

141. Perform the vacuum on the system (ref. PR.10114-268).

142. Fill the system with the refrigerant (ref. PR10114-264).

143. Into the evaporator compartment, disconnect the C24 pin connector with the C24 socket connector.
144. Install the corresponding plug on both connectors.
145. Use cable ties to fix the connectors with the cable tie holder (Figure 71).

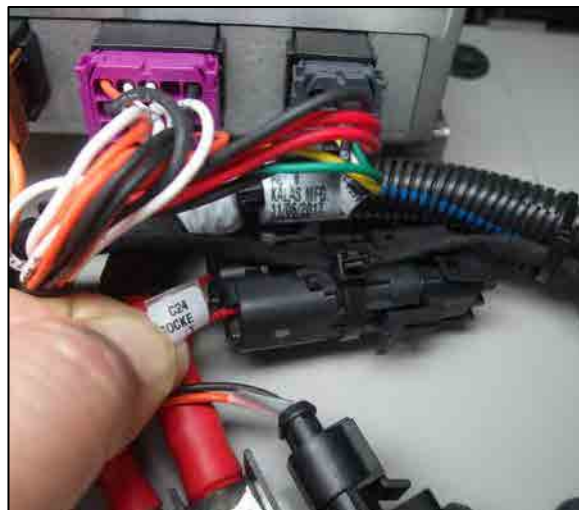

FIGURE 71

146. Into the front service compartment, disconnect the C44 pin connector with the C44 socket connector.
147. Install the corresponding plug on both connectors.
148. Use cable ties to fix the connectors with existing wiring (Figure 72).
149. Bulletin is complete.

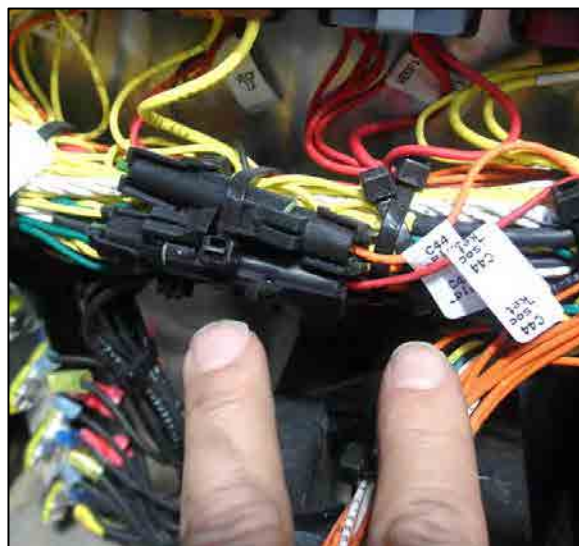

FIGURE 72

## PARTS / WASTE DISPOSAL

Discard waste according to applicable environmental regulations (Municipal/State[Prov.]/ Federal)