

PREVOST

Instruction Sheet

IS-13009D

660699 DRAGLINK ADJUSTMENT

For X Series and H Series vehicles equipped with an I-beam front axle

H Series: From R-1020 up to E-2504

X Series: From Y-7046 up to E-5525

Can replace the following drag links: 160959; 161329; 161378; 161870

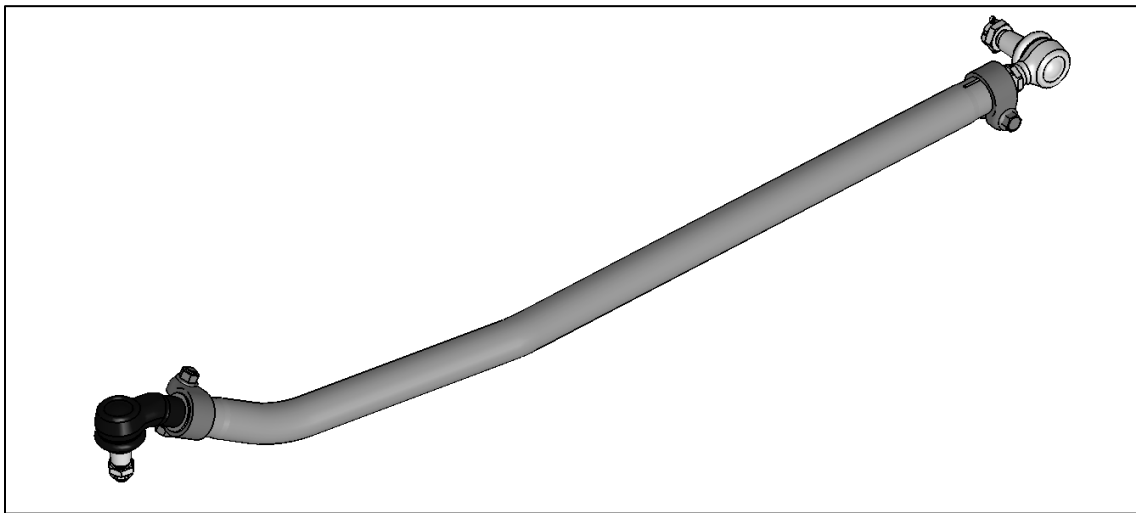

PART NO 660699

Revision : D

Jan 23, 2019

This revision supersedes any previous release

Changed wording in steps 7&8.

MATERIAL

Kit #161458 includes the following parts:

Part No.	Description	Qty
660699	DRAG LINK ASSEMBLY	1
502104	COTTER PIN 5/32X2	2
IS-13009	INSTRUCTION SHEET	1
FI-13009	FEUILLE D'INSTRUCTIONS	1

NOTE

Material can be obtained through regular channels.

PROCEDURE



CAUTION

CONFORM TO THE PRESCRIBED TORQUES AND FOLLOW ASSEMBLY GUIDELINES TO ENSURE VEHICLE SAFETY.



DANGER

Park vehicle safely, apply parking brake, stop engine and set battery master switch(es) to the OFF position prior to working on the vehicle.



PINCH HAZARD

Keep hands and fingers clear of pinch zones around pitman arm.
Pinch zones are between pitman arm and clamp, and between front of pitman arm and vehicle structure.

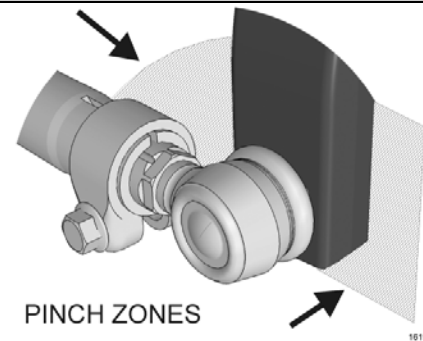

REMOVAL OF EXISTING DRAG LINK

1. Raise the vehicle by the wheels using mobile column lifts. Doing so will prevent a change in direction of the knuckles and preserve the relative positions of the steering components involved i.e. the steering arm and the pitman arm.
2. Remove cotter pin and nut from drag link ball joint stud at pitman arm.
3. Disconnect drag link from pitman arm, using jaw style pullers (pressure screw type).



CAUTION

Heating of components to aid in disassembly is not allowed because it has a detrimental effect on axle components and steering linkages.



CAUTION

Do not drive (hammer in) pitman arm on or off pitman shaft as this can damage the steering gear.

4. Remove cotter pin and nut from drag link ball joint stud at the steering arm (near knuckle) and then disconnect the drag link.

ADJUSTING THE DRAG LINK TO PROPER LENGTH - ELBOW BALL JOINT (KNUCKLE SIDE)

5. Check if the pre-adjusted length of the drag link is correct. To do so, try to install it between the steering arm and the pitman arm. If the length is not adequate, it must be adjusted to the required length. Use dimension "A" to adjust the length of the replacement drag link or you may use the replaced drag link for length reference.

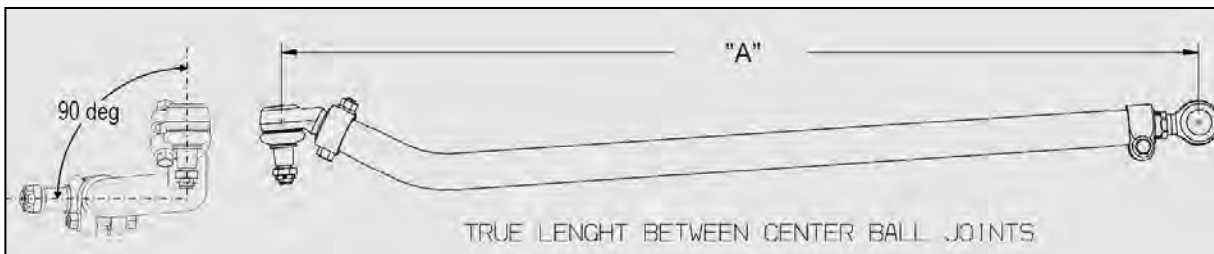

FIGURE 1

X3 series from Y-7046 up to E-5525
length A = 52" 3/8" ± 1/16" (1330mm ± 2mm)

H3 series early model years R-1020 up to A-1604
length A = 52" 3/8" ± 1/16" (1330mm ± 2mm)

H3 series from A-1605 up to E-2504
length A = 53" 3/8" ± 1/16" (1356mm ± 2mm)

6. Screw the drag link elbow ball joint (knuckle side) fully in drag link tube.



FIGURE 2

X3 AND EARLY MODEL YEARS H3 ONLY

7. Screw out the *drag link elbow* ball joint by **(not more than 1 turn)** so the tapered shank *points down* as shown on. (FIGURE 3)

This will be the *initial / reference* position for next step.



FIGURE 3

X3 AND EARLY MODEL YEARS H3 ONLY

8. Next, unscrew the *drag link elbow* ball joint back out **one (1) full turn** from the *initial / reference* position.

The tapered shank must point down as shown on (FIGURE 4).



FIGURE 4

H3 SERIES FROM A-1605 up to E-2504

The limits of the adjustment sleeve do not provide enough extension.

9. Unscrew the *drag link elbow* ball joint out **1 inch**. The tapered shank must point down as shown on **FIGURE 5**.

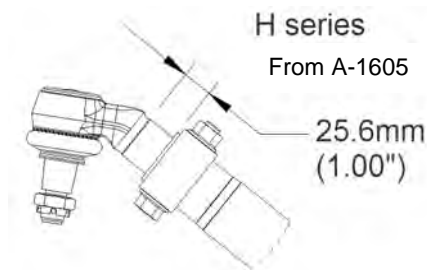

FIGURE 5

10. To prevent interference between the ball joint clamp bolts and other components of the steering system, the clamp bolt must be positioned vertically as shown on FIGURE 6. **Tighten the clamp nut to 118-133 lbf-ft.**



CAUTION

Do not re-use clamp hardware.

Bolt and nut should be replaced every time they are unscrewed. While assembling the clamp, make sure the bolt does not touch the drag link tube.

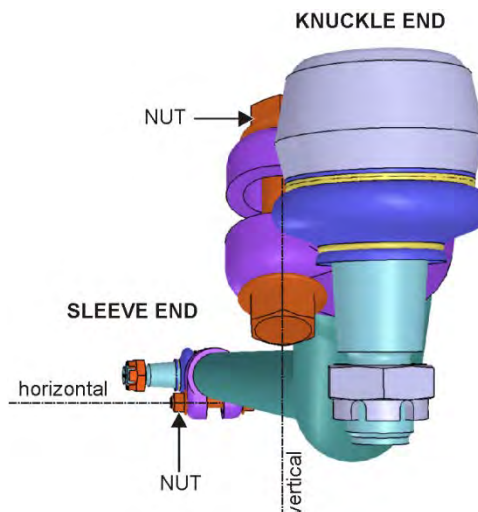

FIGURE 6: NOTE THE VERTICAL ORIENTATION OF THE CLAMP BOLT AT THE KNUCKLE END AND ON WHICH SIDE THE NUT MUST BE POSITIONED

SLEEVE ADJUSTMENT PARAMETERS

11. On the drag link front end you will find an adjustment sleeve which has internal and external left and right threads.

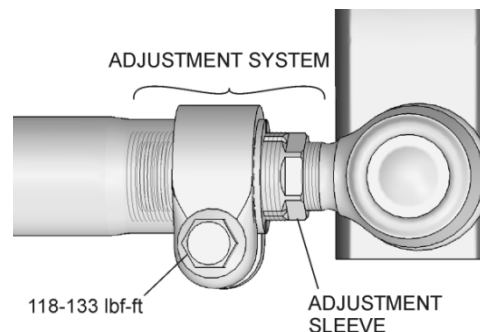

FIGURE 7

12. Fine adjustment of the drag link length if required should be performed exclusively by turning the adjustment sleeve while preventing the tube and joint from rotating.

TURN ADJUSTMENT SLEEVE COUNTER CLOCKWISE TO REDUCE LENGTH

The only part rotating should be the sleeve

- To extend, turn the sleeve clockwise.
- To retract, turn counter clockwise.

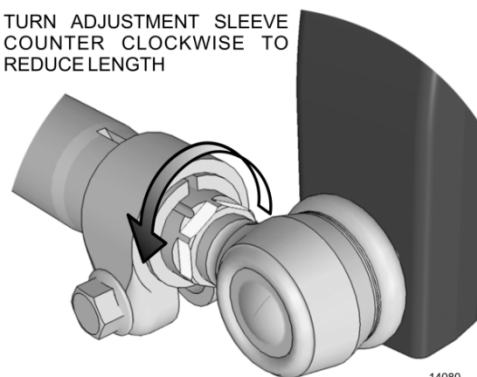

FIGURE 8

GENERAL LIMITATIONS OF THE ADJUSTMENT SLEEVE

Do not exceed the following maximum thread lengths and values.

- Max dimension **V** : 5/8" (16mm) ± 1 thread pitch
- Max dimension **W** : 5/8" (16mm) ± 1 thread pitch
- Max dimension **X** : 1" (25mm)
- Dimension **V** and **W** should be equal ($V/W = 1$)

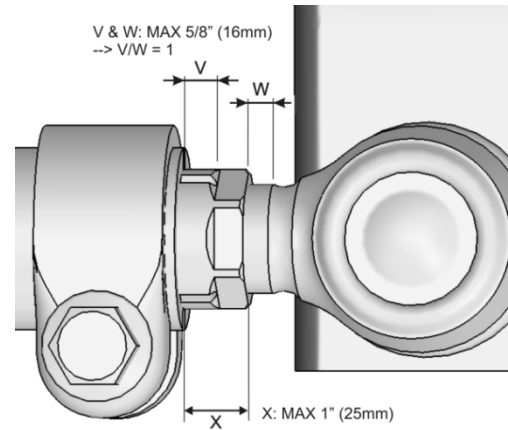

FIGURE 9

SLEEVE ADJUSTMENT

X3 AND EARLY MODEL YEARS H3 ONLY

13. Adjust sleeve to the values of FIGURE 10.

$$5/8" = 16\text{mm}$$

$$10/32" = 8\text{mm}$$

14. Once the proper length adjustment is done, tighten the sleeve end ball joint clamp. To prevent interference between the ball joint clamp bolts with other components of the steering system, the clamp bolt must be positioned horizontally as shown on FIGURE 11. **Tighten the clamp nut to 118-133 lbf-ft.**

X SERIES: from Y-7046 incl. up to today
H SERIES: from R-020 up to A-1604 incl.

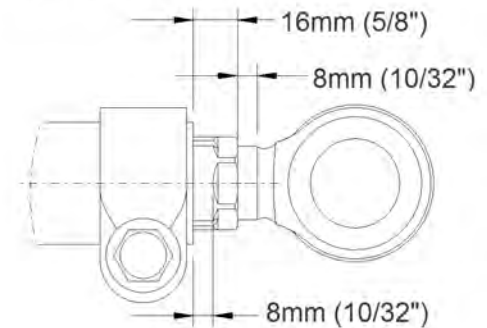

FIGURE 10

CAUTION

Do not re-use clamp hardware.

Bolt and nut should be replaced every time they are unscrewed. While assembling the clamp, make sure the bolt does not touch the drag link tube.

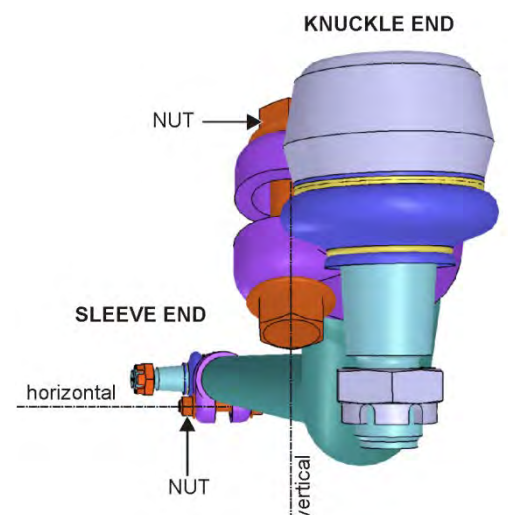

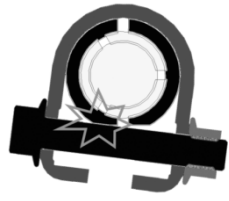

FIGURE 11: NOTE THE HORIZONTAL ORIENTATION OF THE CLAMP BOLT AT THE SLEEVE END AND ON WHICH SIDE THE NUT MUST BE POSITIONED

H3 SERIES FROM A-1605 up to E-2504

15. Adjust sleeve to the values of FIGURE 12.
16. Once the proper length adjustment is done, tighten the adjustment sleeve clamp. To prevent interference between the ball joint clamp bolts with other components of the steering system, the clamp bolt must be positioned horizontally as shown on FIGURE 13. **Tighten the clamp nut to 118-133 lbf-ft.**

	CAUTION
Do not re-use clamp hardware.	
Bolt <u>and</u> nut should be replaced every time they are unscrewed. While assembling the clamp, make sure the bolt <u>does not touch</u> the drag link tube.	
	

H series: from A-1605

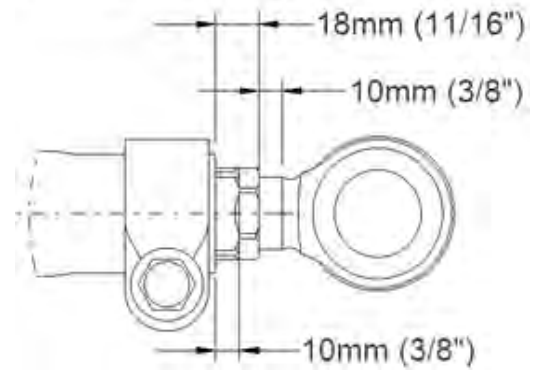

FIGURE 12

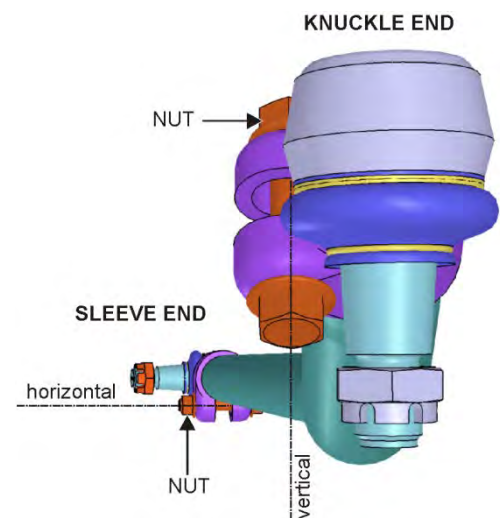

FIGURE 13: NOTE THE HORIZONTAL ORIENTATION OF THE CLAMP BOLT AT THE SLEEVE END AND ON WHICH SIDE THE NUT MUST BE POSITIONED

DRAG LINK INSTALLATION

17. Install the drag link.
18. Secure the ball joint with a castellated nut at both ends. Tightened the castellated nuts to **150-200 lbf-ft**.
19. Install cotter pin **p/n 502104** at both ends to secure the ball joint nut and bend to lock bolt in place (see an example of a correct installation of a cotter pin on the image below).
20. Apply a small amount of anti-seize compound on all exposed threads for corrosion protection. Be sure to avoid smearing the ball joint boot.

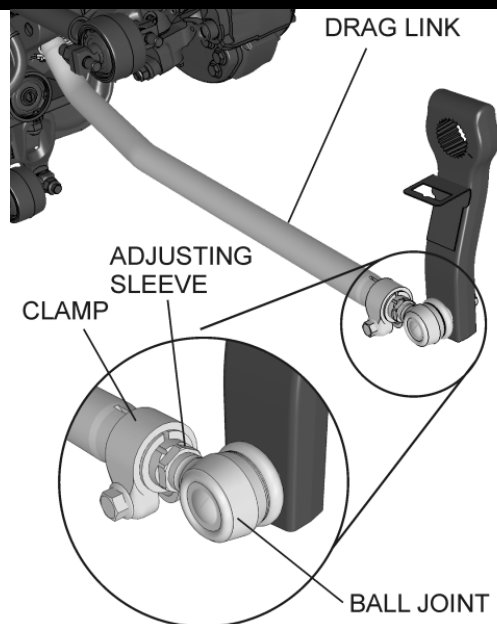
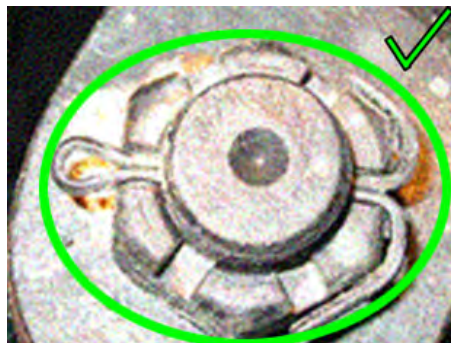

FIGURE 14

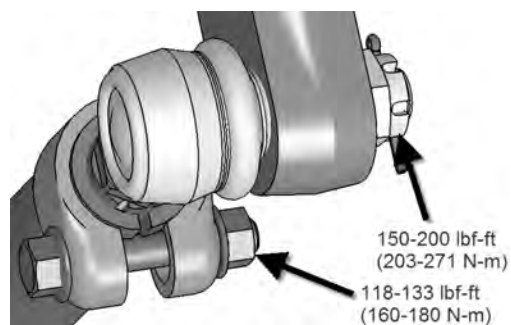

FIGURE 15

PARTS / WASTE DISPOSAL

Discard waste according to applicable environmental regulations (Municipal/State[Prov.]/ Federal)