



---

# SERVICE BULLETIN

---

Classification:

EM18-002

Reference:

NTB19-006

Date:

January 22, 2019

---

## 2015-2017 ALTIMA WITH 4-CYL ENGINE; EXHAUST LEAK FROM EXHAUST MANIFOLD

**APPLIED VEHICLES:** 2015-2017 Altima (L33)

**APPLIED ENGINE:** QR25DE (4-cyl)

### IF YOU CONFIRM

An exhaust leak is coming from the exhaust manifold

### AND

A crack is found in the exhaust manifold.

- See page 2, Figure 1.

### ACTION

Replace the exhaust manifold and exhaust tube.

- For 2015-2016 Altima: Refer to the Electronic Service Manual (ESM), sections EM-Engine Mechanical and EX-Exhaust System, for exhaust manifold and exhaust tube replacement procedures, respectively.
- For 2017 Altima: Refer to the ESM, section ENGINE / ENGINE MECHANICAL / QR25DE and ENGINE / EXHAUST SYSTEM / QR25DE, for exhaust manifold and exhaust tube replacement procedures, respectively.

Nissan Bulletins are intended for use by qualified technicians, not 'do-it-yourselfers'. Qualified technicians are properly trained individuals who have the equipment, tools, safety instruction, and know-how to do a job properly and safely. NOTE: If you believe that a described condition may apply to a particular vehicle, DO NOT assume that it does. See your Nissan dealer to determine if this applies to your vehicle.

Example of an incident exhaust manifold (see Figure 1).

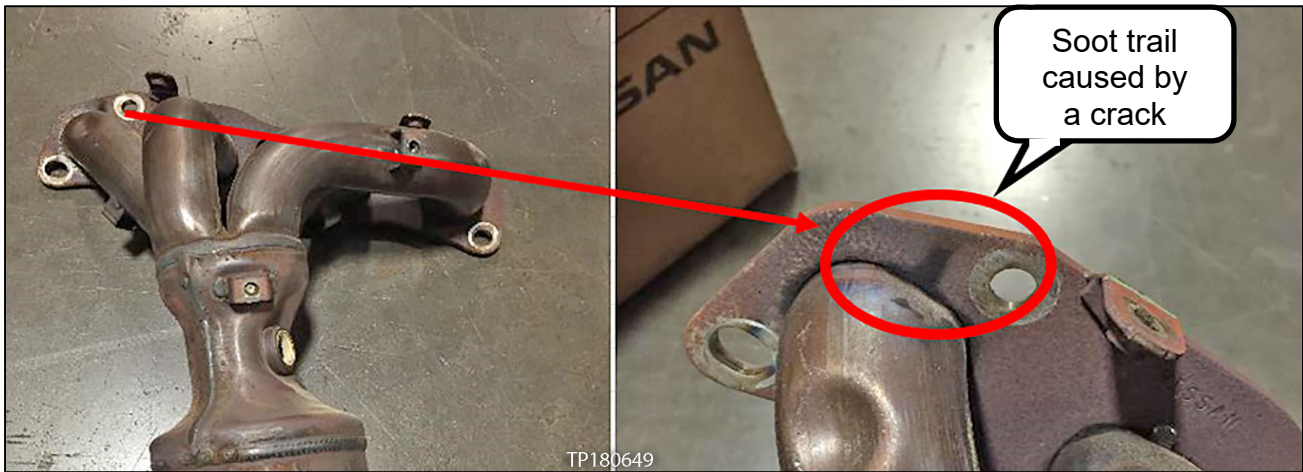

Figure 1

Replace parts 1 and 2 (see Figures 2 and 3).

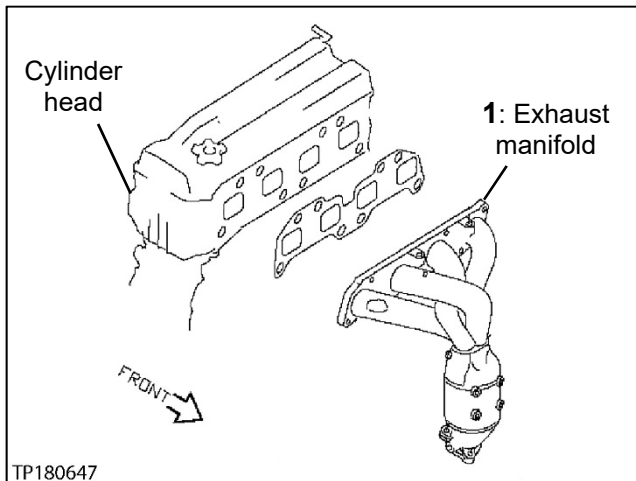

Figure 2

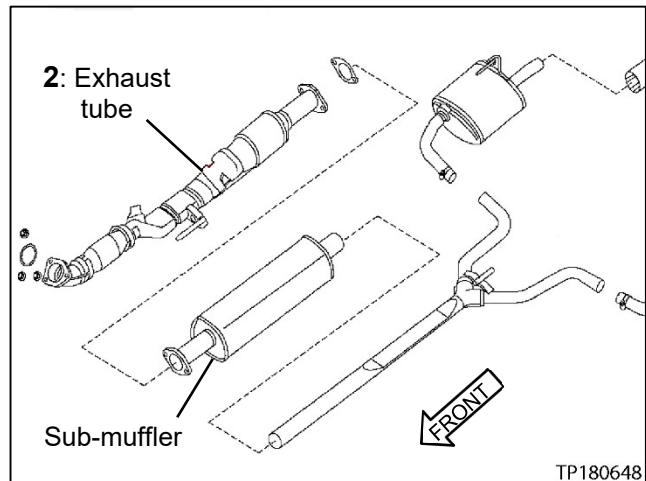

Figure 3

## PARTS INFORMATION

ALTIMA: MODEL YEAR	DESCRIPTION	PART NUMBER	QUANTITY
2015-2017	MANI ASSY-EXH W/CAT ("Federal" vehicles)	140E2-3TA0A	1
2015	MANIFOLD ASSY-EXHAUST W/CATALYST ("California" vehicles)	140E2-3TY0A	1
2016-2017	MANIFOLD ASSY-EXHAUST W/CATALYST ("California" vehicles)	140E2-9HS0A	1
2015-2017	TUB-EXH FRONT W/ CATALYST ("Federal" vehicles)	20010-3TA3A	1
2015	TUB-EXH-FRONT W/CAT ("California" vehicles)	20010-3TA2A	1
2016-2017	TUB-EXH-FRONT W/CAT ("California" vehicles)	20010-9HS0A	1
2015-2017	GASKET-EXHAUST MANIFOLD, A	14036-3TA0B	1
2015-2017	GASKET-EXHAUST (front tube)	20692-24U0A	1
2015-2017	GASKET-EXHAUST (front tube ring)	20691-19U0A	1
2015-2017	NUT	01223-N0021	3
2015-2017	NUT	14094-9BA0A	5
2015-2017	STUD-EXHAUST (exhaust manifold)	14064-ZX60A	5
2015-2017	STUD (lower catalystr)	14064-JG30B	3
2015-2017	BOLT (heat shield)	14069-JD70A	11

## CLAIMS INFORMATION

Submit a Primary Part (PP) type line claim using the following claims coding:

DESCRIPTION	PFP	OP CODE	SYM	DIA	FRT
R&I Exhaust Manifold	(1)	AR12AA	AN	01	(2)
R&I Exhaust Tube		FD10AA			

- (1) Reference the Electronic Parts Catalog (EPC), and use the Exhaust Manifold Assy (140E2-\*\*\*\*\*) as the Primary Failed Part (PFP).
- (2) Reference the current Nissan Warranty Flat Rate Manual and use the indicated Flat Rate Time (FRT).

## AMENDMENT HISTORY

PUBLISHED DATE	REFERENCE	DESCRIPTION
January 22, 2019	NTB19-006	Original bulletin published