

## Hands-Free Access Power Tailgate Not Working?

### AFFECTED VEHICLES

All models with the hands-free access power tailgate or accessory hands-free access power tailgate

**EDITOR'S NOTE:** This article replaces the one posted in **September 2017**.

Is the hands-free access power tailgate not working or not working like it should? Before you start any heavy troubleshooting, make sure you're using the right motion to activate the hands-free access power tailgate control unit/sensor; it won't activate unless you do.

Here's how you **should** be doing it. We're showing you this on a 2018 Odyssey, but it's the **same** motion for all other affected models. Keep in mind, however, the size and number of target areas will vary, depending on the model and whether it has an accessory trailer hitch. You'll find all of this explained in the applicable hands-free access power tailgate user's information manual on SIS.

*With the smart entry remote on you, kick your foot up under the rear bumper in the center of the target area(s) as shown. Make sure you're kicking straight up and straight back (no side-to-side motion), and it's smooth and continuous (don't stop anytime during your kick, and don't hit the bumper). Also, watch the timing of your kick; you want to keep it to about **1 second** in length.*

#### 2018 ODYSSEY SHOWN

*Without Accessory Trailer Hitch*

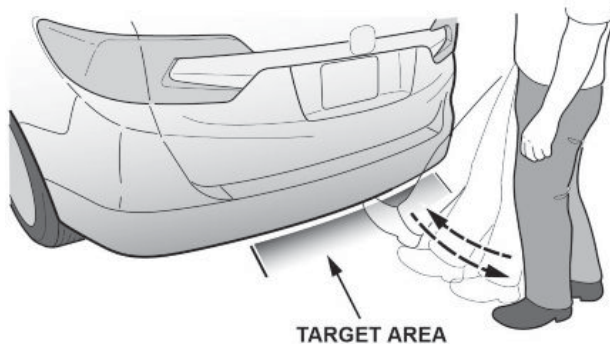

#### 2018 ODYSSEY SHOWN

*With Accessory Trailer Hitch*

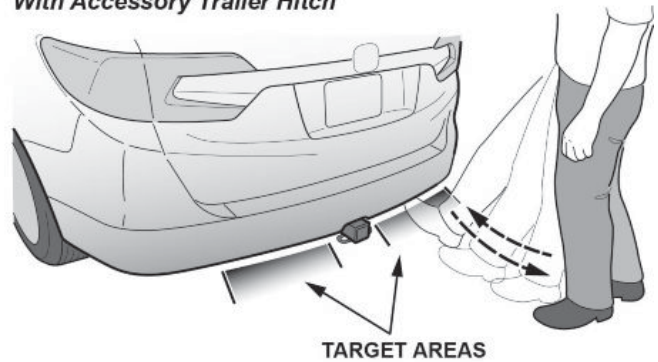

Of course, if you're using the right motion and the power tailgate **still** isn't working properly, then continue with normal system troubleshooting.