

HUSQVARNA TECHNICAL BULLETIN TB1806

JUNE 21, 2018

REPLACEMENT OF AUTO-DECOMPRESSION SYSTEM COMPONENTS

**AFFECTED MODELS: 2018 VITPILEN 701, 701 SUPERMOTO,
701 ENDURO**

**RESTRICTIONS: AFFECTED MODELS ARE LINKED BY VIN IN
HUSQVARNA DEALER.NET**

Initial Information:

During the course of quality controls, Husqvarna Motorcycles North America, Inc has found that the tolerances between the decompression weight and decompression screw (marked in blue) are not in specification on select 2018 701 model motorcycles. These auto-decompression system components must be replaced to prevent premature wear.

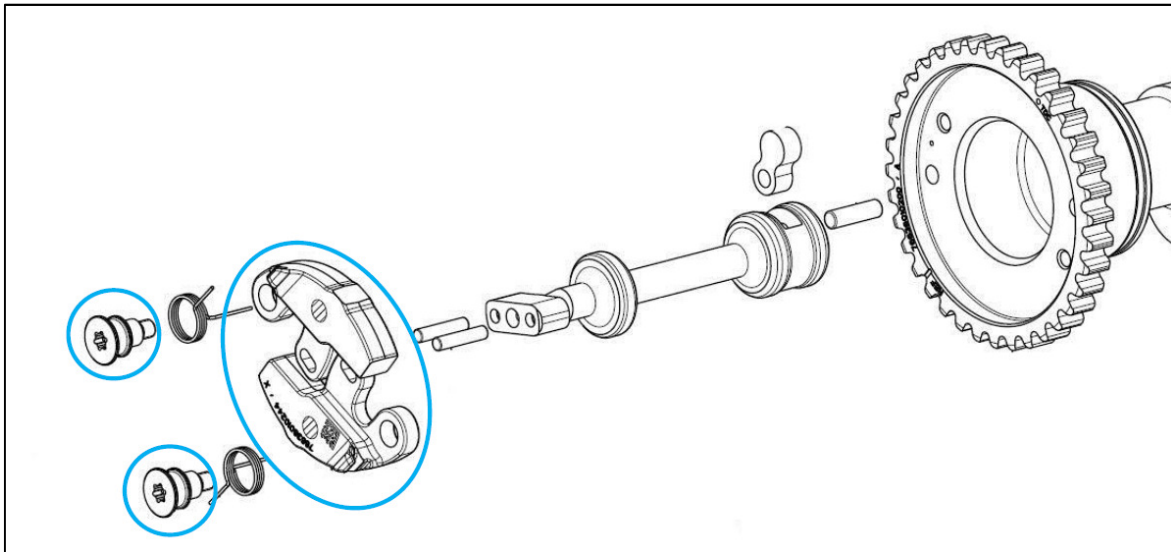

Husqvarna Motorcycles North America, Inc. is recommending that the auto-decompression system components are replaced on all affected 2018 701 model motorcycles including the current inventory prior to PDI following the procedures given later in this document. Please contact all of your customers who own affected motorcycles to have the auto-decompression system components replaced as soon as possible.

COPYRIGHT NOTICE

The user acknowledges that all components of this technical information are Husqvarna's and/or third parties' copyright protected property. Alteration, assignment, distribution and reproduction are forbidden.

LIMITATION OF LIABILITY

The information included in or available through this technical information may include inaccuracies or errors. In no event shall Husqvarna and/or its suppliers be liable for any damages whatsoever, arising out of or in connection with the use of this technical information. Please always refer to the Husqvarna owners and repair manuals for proper instructions or contact the Husqvarna Dealer Services Department. ©2018 Husqvarna Motorcycles North America, Inc. – All rights reserved

HUSQVARNA TECHNICAL BULLETIN TB1806

JUNE 21, 2018

PROCEDURE FOR REPAIR:

You do not need to remove the engine to perform this repair. The following photos are for reference only.

Please reference the latest HTML repair manual in the Husqvarna Dealer.net download center, or on the CD-Rom (p.n. 3.403.071) for additional instructions and tightening torques.

1. Remove the passenger and rider seat.
2. Remove the fuel tank.
3. Place the hoses and cables to one side.
4. Remove the valve cover (the valve cover seal can be reused if not damaged).
Note: Cover the timing chain tunnel opening to prevent parts from falling inside the engine.
5. Remove the screw (1) with the O-ring in order to rotate the engine to ignition top dead center.

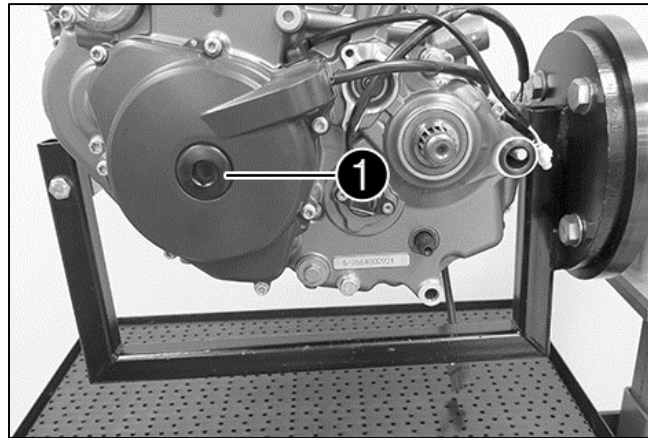

6. Rotate the crankshaft counterclockwise until the balancer shaft (2) and camshaft (3) markings align with the arrow markings of the camshaft bearing support.

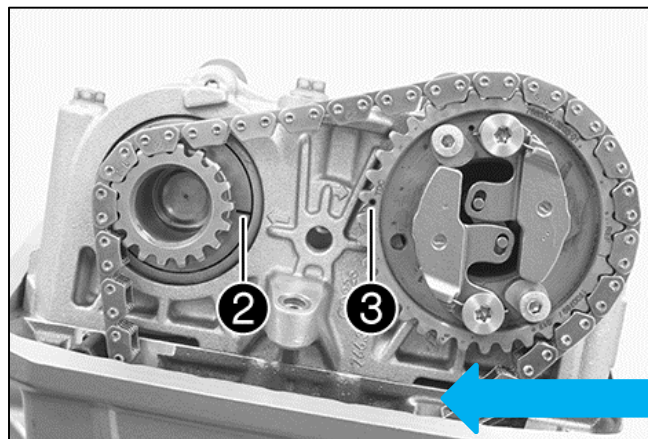

Cover this area
with a clean shop
towel to prevent
parts from falling
inside the engine.

COPYRIGHT NOTICE

The user acknowledges that all components of this technical information are Husqvarna's and/or third parties' copyright protected property. Alteration, assignment, distribution and reproduction are forbidden.

LIMITATION OF LIABILITY

The information included in or available through this technical information may include inaccuracies or errors. In no event shall Husqvarna and/or its suppliers be liable for any damages whatsoever, arising out of or in connection with the use of this technical information. Please always refer to the Husqvarna owners and repair manuals for proper instructions or contact the Husqvarna Dealer Services Department. ©2018 Husqvarna Motorcycles North America, Inc. – All rights reserved

HUSQVARNA TECHNICAL BULLETIN TB1806

JUNE 21, 2018

7. Loosen the auto-decompression screws (4) (Torx 25) by two turns and detach springs (5) on the auto-decompression weight (6).

Note: The adjusting screws (Allen Head socket) must not be loosened.

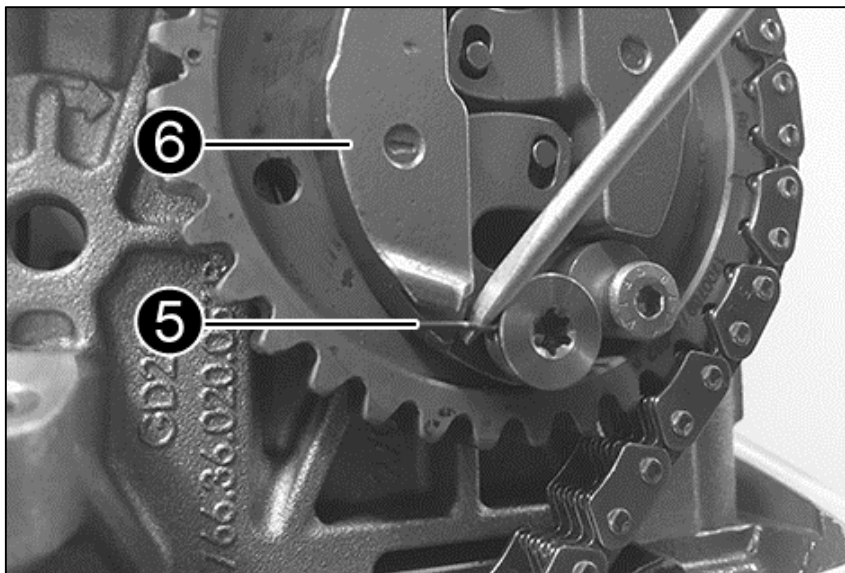
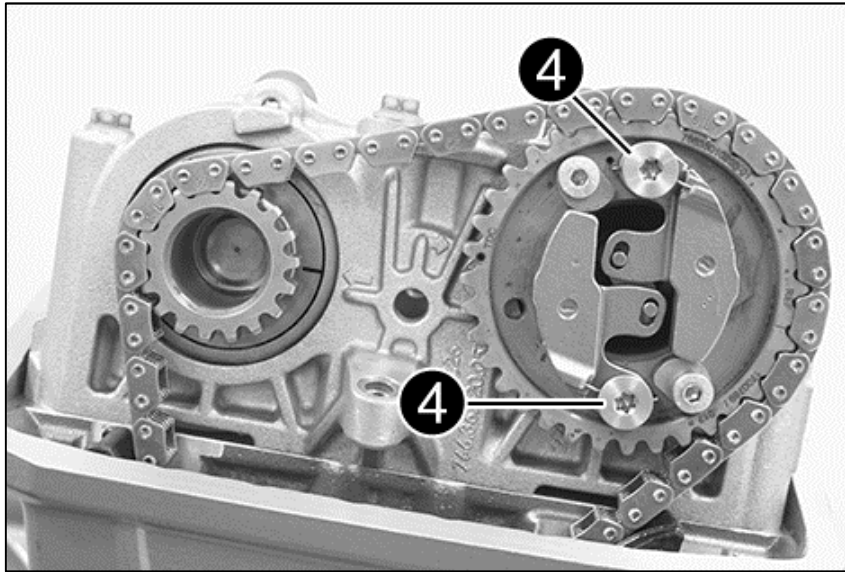

COPYRIGHT NOTICE

The user acknowledges that all components of this technical information are Husqvarna's and/or third parties' copyright protected property. Alteration, assignment, distribution and reproduction are forbidden.

LIMITATION OF LIABILITY

The information included in or available through this technical information may include inaccuracies or errors. In no event shall Husqvarna and/or its suppliers be liable for any damages whatsoever, arising out of or in connection with the use of this technical information. Please always refer to the Husqvarna owners and repair manuals for proper instructions or contact the Husqvarna Dealer Services Department. ©2018 Husqvarna Motorcycles North America, Inc. – All rights reserved

HUSQVARNA TECHNICAL BULLETIN TB1806

JUNE 21, 2018

8. Remove the screws, weights and springs from the camshaft. Take a photo of the parts removed and attach them to the warranty claim that will be submitted for the repair.
9. Thoroughly degrease and clean the screw threads to ensure proper adhesion with the new precoated screws (7).

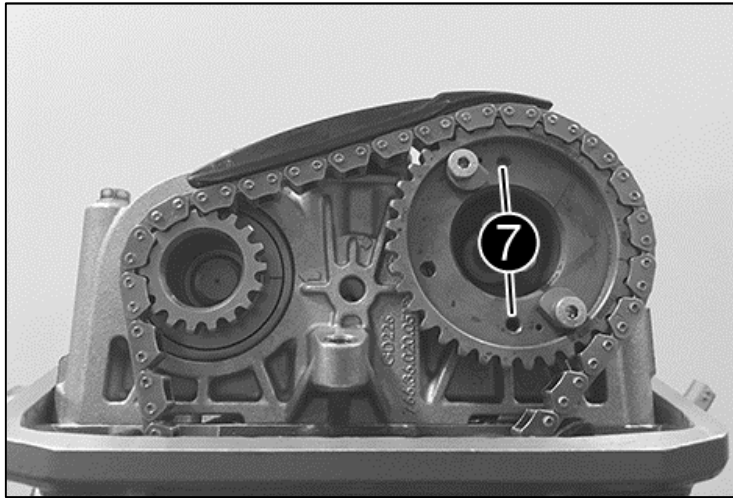

10. Position the spring (5) and the (new) weight (6).

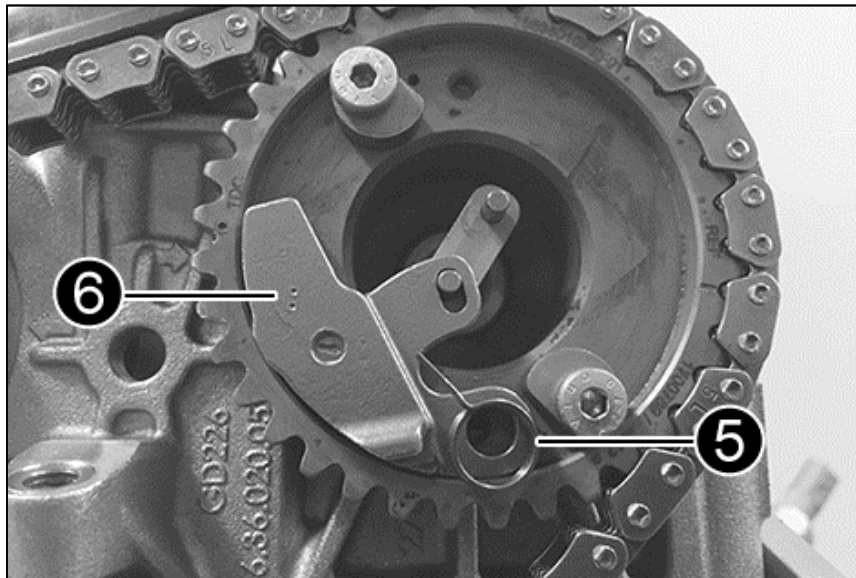

COPYRIGHT NOTICE

The user acknowledges that all components of this technical information are Husqvarna's and/or third parties' copyright protected property. Alteration, assignment, distribution and reproduction are forbidden.

LIMITATION OF LIABILITY

The information included in or available through this technical information may include inaccuracies or errors. In no event shall Husqvarna and/or its suppliers be liable for any damages whatsoever, arising out of or in connection with the use of this technical information. Please always refer to the Husqvarna owners and repair manuals for proper instructions or contact the Husqvarna Dealer Services Department. ©2018 Husqvarna Motorcycles North America, Inc. – All rights reserved

HUSQVARNA TECHNICAL BULLETIN TB1806

JUNE 21, 2018

11. Position the (new) screw and turn in 5-6 rotations.
12. Install the spring (5) on the weight and ensure correct installation position.
13. Repeat steps 10, 11 and 12 with the other weight, spring and screw.

Note: The spring must not become trapped (See the blue arrows).

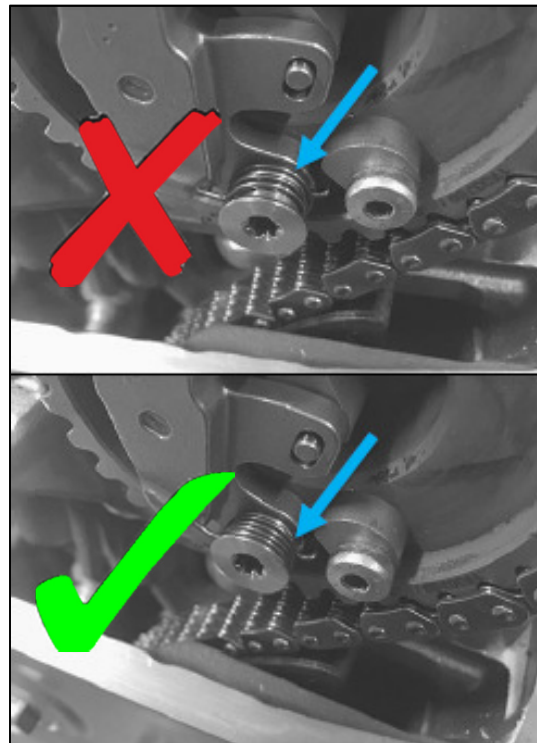
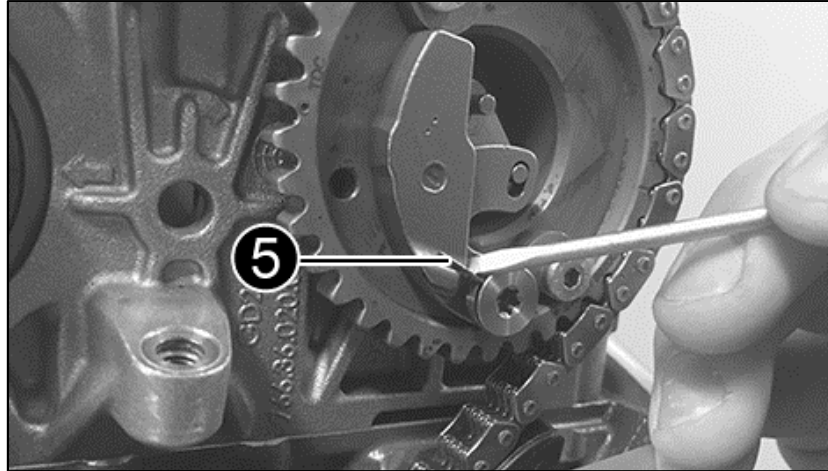

COPYRIGHT NOTICE

The user acknowledges that all components of this technical information are Husqvarna's and/or third parties' copyright protected property. Alteration, assignment, distribution and reproduction are forbidden.

LIMITATION OF LIABILITY

The information included in or available through this technical information may include inaccuracies or errors. In no event shall Husqvarna and/or its suppliers be liable for any damages whatsoever, arising out of or in connection with the use of this technical information. Please always refer to the Husqvarna owners and repair manuals for proper instructions or contact the Husqvarna Dealer Services Department. ©2018 Husqvarna Motorcycles North America, Inc. – All rights reserved

HUSQVARNA TECHNICAL BULLETIN TB1806

JUNE 21, 2018

13. Tighten the auto-decompression screws (4) (Torx 25) to 4 Nm.

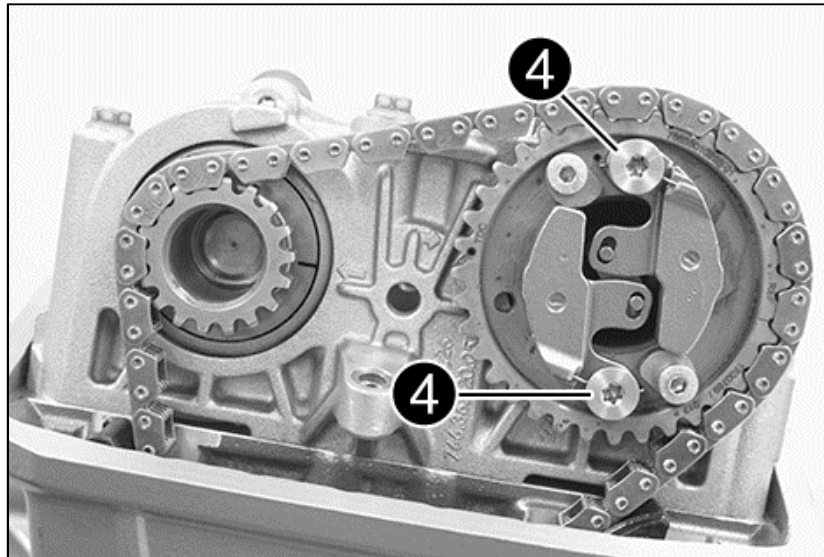

14. Check the following points:

- Spring is correctly fitted and positioned
- Weight is correctly positioned
- Check freedom of movement by hand

15. Clean the sealing areas.

16. Check the valve cover seal for any damage and replace if necessary.

Note: Check and verify correct position of ventilation flange gasket (8).

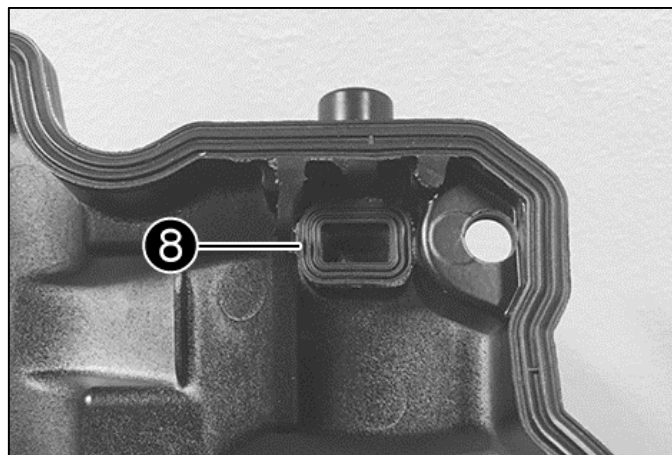

COPYRIGHT NOTICE

The user acknowledges that all components of this technical information are Husqvarna's and/or third parties' copyright protected property. Alteration, assignment, distribution and reproduction are forbidden.

LIMITATION OF LIABILITY

The information included in or available through this technical information may include inaccuracies or errors. In no event shall Husqvarna and/or its suppliers be liable for any damages whatsoever, arising out of or in connection with the use of this technical information. Please always refer to the Husqvarna owners and repair manuals for proper instructions or contact the Husqvarna Dealer Services Department. ©2018 Husqvarna Motorcycles North America, Inc. – All rights reserved

HUSQVARNA TECHNICAL BULLETIN TB1806

JUNE 21, 2018

17. Mount the screw (1) with the O-ring and tighten (8 Nm).

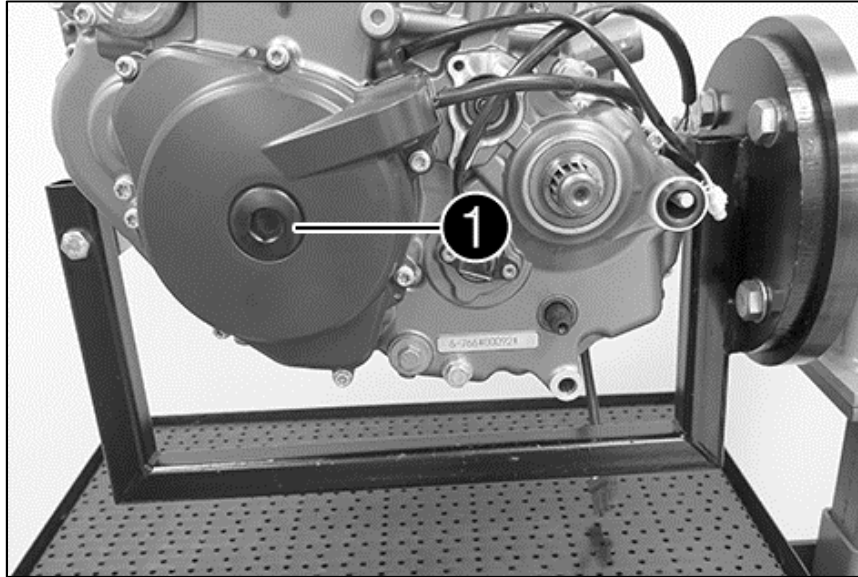

18. The remaining components are installed in reverse order according to the repair manual.

19. Start the engine and check to be sure there are no oil leaks and the auto-decompression allows easy starting after replacement.

TORQUE SPECIFICATIONS:

Component	Screw	Tightening Torque	Remark
Auto-decompression screw	M4x0.5	4 Nm	Precoated with Loctite
Screw, valve mechanism cover	M6	10 Nm	
Screw in ignition cover	M24x1.5	8 Nm	

PARTS ORDERING:

1 QTY. 76636015044 (Decompression weight repair kit)

COPYRIGHT NOTICE

The user acknowledges that all components of this technical information are Husqvarna's and/or third parties' copyright protected property. Alteration, assignment, distribution and reproduction are forbidden.

LIMITATION OF LIABILITY

The information included in or available through this technical information may include inaccuracies or errors. In no event shall Husqvarna and/or its suppliers be liable for any damages whatsoever, arising out of or in connection with the use of this technical information. Please always refer to the Husqvarna owners and repair manuals for proper instructions or contact the Husqvarna Dealer Services Department. ©2018 Husqvarna Motorcycles North America, Inc. – All rights reserved

HUSQVARNA TECHNICAL BULLETIN TB1806

JUNE 21, 2018

WARRANTY INPUT INFORMATION:

This Technical Bulletin only affects certain VIN numbers! Please check the VIN by performing a Motorcycle History search in Husqvarna Dealer.net to determine if it's affected. If the motorcycle is affected you will see a link to the bulletin and its repair status in the history results. Husqvarna Motorcycles North America, Inc. will not warranty units whose VIN numbers are not listed as this bulletin does not apply to them. It is the responsibility of the dealer to determine if the unit requires this update by checking the vehicle history and understanding the instructions provided by this bulletin.

Please note that when entering a warranty claim on an affected model, you must perform a history search, expand the **Technical Information** window, click the blue arrow on the right side of the corresponding bulletin message.

You can now choose the TI Number from the list. The TI number for this procedure is according to the repairs performed and listed in the warranty claim input information; click **Continue with selected action code**.

The Warranty Claim is automatically entered for you, including parts & labor. You must enter additional information in the required fields marked with an asterisk "*" before submitting the claim to Husqvarna Motorcycles. The flat rate time for this repair is based on the action performed and provided in minutes.

WARRANTY CLAIM INPUT INFORMATION	
Warranty type:	TI Warranty
Subassembly group:	36 – Timing Drive
Failure code:	420 – Wearing
Part causing failure:	76636010244 – Camshaft, complete
Campaign code:	36_776610_00 Replacement of auto-decompression system components
Spare parts:	1 QTY. 76636015044 – Decompression weight repair kit
Labor time:	60 minutes
Stock parts affected:	No

COPYRIGHT NOTICE

The user acknowledges that all components of this technical information are Husqvarna's and/or third parties' copyright protected property. Alteration, assignment, distribution and reproduction are forbidden.

LIMITATION OF LIABILITY

The information included in or available through this technical information may include inaccuracies or errors. In no event shall Husqvarna and/or its suppliers be liable for any damages whatsoever, arising out of or in connection with the use of this technical information. Please always refer to the Husqvarna owners and repair manuals for proper instructions or contact the Husqvarna Dealer Services Department. ©2018 Husqvarna Motorcycles North America, Inc. – All rights reserved