



DUAL STEERING GEAR AIR BLEED PROCEDURE

1. With the weight of the vehicle off the ground, start the engine and let it run at idle speed. The draglink should be connected to the pitman arm on the master (main) gear, but not connected to the slave (auxiliary) gear.
2. Turn the steering wheel all the way to the left until the axle stop contacts the axle and hold pressure on the steering wheel until the pitman arm on the slave gear moves its full travel. It must move in the opposite direction of the pitman arm on the master gear. Maintain pressure on the steering wheel for 15 seconds after the slave gear stops moving.

NOTICE

Turning pressure must be maintained on the steering wheel to keep the valve open which sends fluid pressure from the master gear to the slave gear. As soon as turning pressure is released from the steering wheel, the control valve returns to the neutral position and fluid is returned only to the reservoir.

3. Now turn the steering wheel all the way to the right until the axle stop contacts the axle and hold pressure on the steering wheel until the pitman arm on the slave gear moves its full travel in the opposite direction. Maintain pressure on the steering wheel for 15 seconds after the slave gear stops moving.
4. Repeat the procedure 3 more times or until there is no air in the system and the slave gear moves as soon as the steering wheel is turned.
5. Turn the steering wheel until the pitman arm on the slave gear aligns with the draglink and install the draglink. Tighten per the manufacturer's specifications. Do not move the pitman arm on the slave gear by hand as air may be drawn into the system.
6. Cycle the steering from stop to stop. If a bind or hesitation is noticed, look for bleeder screws on the steering gear if the gear is mounted with the bulge in the housing for the sector shaft sitting above the piston cylinder. Open the bleeder no more than 4 turns only when steering and the piston is moving toward the bleeder. Ensure the bleeder screw is closed when the piston moves away from the bleeder.

NOTICE

DO NOT REMOVE THE BLEEDER SCREW! THERE IS A CHECK BALL BENEATH THE SCREW. IF THE CHECK BALL IS LOST THE BLEEDER WILL LEAK. The **yellow arrows** point to the bleeders on the drawings.

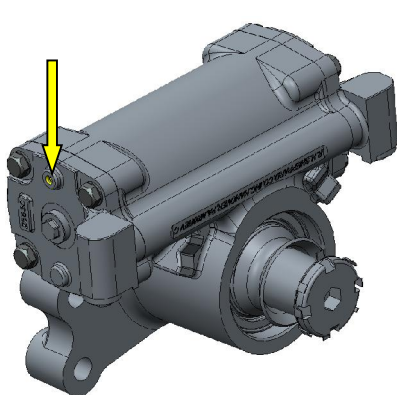

M80SAW1

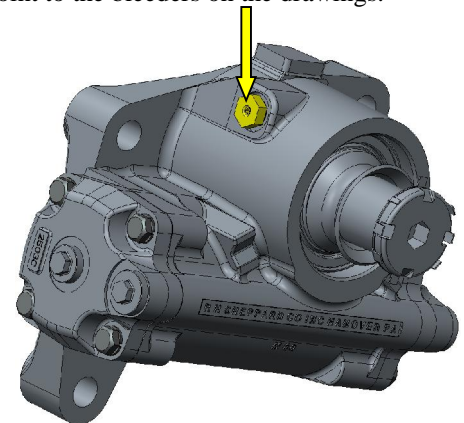
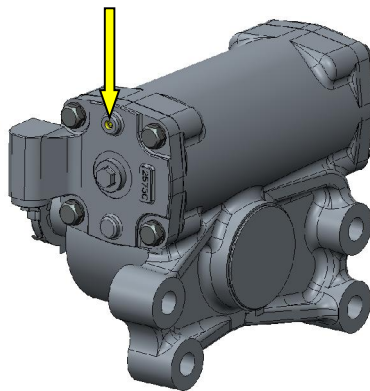

M80SAY1

If you have questions at any time, contact our Field Service Hotline at 1-800-274-7437.