



---

Jason Guidi

---

Director - Regulatory & Compliance

---

August 15, 2018  
Subject: Recall R89898  
TO: All U.S. and Canadian Volvo Retailers

**VEHICLES IN RETAILER INVENTORY**

**It is a violation of federal law for a retailer to deliver any new Volvo that is eligible for a recall. Retailers are advised to check all vehicles in inventory for recall eligibility and repair immediately. Violation of this requirement by a retailer could result in a civil penalty of up to \$21,000 per vehicle.**

**Correct all vehicles in your new vehicle inventory before delivery.**

Volvo Car USA LLC and Volvo Car Canada LTD (Volvo) on behalf of Volvo Car Group has decided to launch Recall R89898 on a **limited** number of model year 2019 XC40 vehicles.

Volvo has identified that the rear seatback lock striker(s) may not have been installed when the vehicle was manufactured.

**PLEASE NOTE**

The corrective action is to inspect the vehicle and verify that both rear seatback lock strikers are installed. If the rear seatback lock strikers are installed on the vehicle, no further action is necessary.

If one or both rear seatback strikers are missing, install them per the instructions below.

A total of 27 U.S. and 10 Canadian vehicles are eligible for this recall.

Vehicle eligibility must be confirmed:

- Vehicle Inquiry – Vehicle Warranty where the message "Recall R89898 Rear Seatback Lock Striker" will appear for eligible vehicles.
- All cars not yet delivered to end customers must be corrected prior to delivery.
- There have been no reports of incidents related to this issue.



If you have any questions concerning this recall send them to [recall@volvocars.com](mailto:recall@volvocars.com).

**OWNER NOTIFICATION**

Volvo Customer Care will contact the vehicle owners and will assist with arranging appointments with the selling retailer.

**PORT VEHICLES**

No vehicles will be shipped from the ports with this recall not completed.

**PARTS / PARTS RETURN**

Please refer to Parts Bulletin 85-R89898.

**CLAIM SUBMISSION**

Please refer to the claim submission information in the attached Quality Bulletin.

**RETAILER RESPONSIBILITIES**

Retailers must perform this recall campaign on eligible vehicles regardless of miles/kilometers or vehicle age. All work performed under this recall is free of charge to the owner.

As the safety of our customers is our utmost priority, we are taking full responsibility to ensure the highest quality and safety standards for our cars.

If you have questions about this recall or any other field service action, please contact me or any member of the Product Safety and Compliance office.

Your cooperation in completing this important recall is greatly appreciated.

Drive Safely,

A handwritten signature in black ink that reads "Jason J. Guidi".

Jason Guidi  
Director - Regulatory & Compliance  
201-768-7300  
[jason.guidi@volvocars.com](mailto:jason.guidi@volvocars.com)



## **Recall R89898: Rear Seatback Lock Strikers**

MODEL YEAR 2019

MODEL: XC40

DATE: 08/15/18

MARKET – U.S. AND CANADA

ISSUING DEPARTMENT: WARRANTY

### **BULLETIN REFERENCE PB 85-R89898**

#### **A. RECALL R89898 DESCRIPTION**

#### **B. VEHICLES INVOLVED**

#### **C. PARTS INFORMATION/PARTS RETURN**

#### **D. OWNER NOTIFICATION**

#### **E. VEHICLES IN RETAILER INVENTORY**

#### **F. RETAILER RESPONSIBILITY**

#### **G. CAMPAIGN REIMBURSEMENT PROCEDURES**

#### **H. TECHNICIAN COMPETENCY REQUIREMENT**

#### **I. RETAILER ALLOWANCE**

### **A. RECALL R89898 DESCRIPTION**

Volvo Car USA LLC and Volvo Car Canada LTD (Volvo) on behalf of Volvo Car Group has decided to launch Recall R89898 on a **limited** number of model year 2019 XC40 vehicles.

Volvo has identified that the rear seatback lock striker(s) may not have been installed when the vehicle was manufactured.

#### **PLEASE NOTE**

The corrective action is to inspect the vehicle and verify that both rear seatback lock strikers are installed. If the rear seatback lock strikers are installed on the vehicle, no further action is necessary.

If one or both rear seatback strikers are missing, install them per the instructions below.

A total of 27 U.S. and 10 Canadian vehicles are eligible for this recall.

### **B. VEHICLES INVOLVED**

**NOTE: RETAILER MUST CONFIRM VEHICLE ELIGIBILITY PRIOR TO BEGINNING THE REPAIR FOR THIS RECALL.**

Vehicle eligibility must be confirmed:

- Vehicle Inquiry – Vehicle Warranty where the message "Recall R89898 Rear Seatback Lock Strikers" will appear for eligible vehicles or check eligibility in TIE.

All vehicles should be checked for any incomplete recalls or service campaigns or service upgrades. All open Recall, Service Campaign or Service Action repairs should be completed. If you have any questions concerning this recall send them to recall@volvocars.com.

### **C. PARTS / PARTS RETURN**

Please refer to Parts Bulletin 85-R89898.

### **PORT VEHICLES**

No vehicles will be delivered from the ports without having this recall performed.

All vehicles must be checked for any incomplete recalls or service campaigns or service upgrades prior to delivery.

### **D. OWNER NOTIFICATION**

Volvo Customer Care will contact the vehicle owners and will assist with arranging appointments with the selling retailer.

### **E. VEHICLES in RETAILER INVENTORY**

It is a violation of federal law for a retailer to deliver any new Volvo that is eligible for a recall.

Retailers are advised to check all vehicles in inventory for recall eligibility and repair immediately.

Violation of this requirement by a retailer could result in a civil penalty of up to \$21,000 per vehicle. Correct all vehicles in your new vehicle inventory before delivery.

### **F. RETAILER RESPONSIBILITY**

All vehicles qualifying for this recall must be repaired prior to a customer taking possession of the vehicle.

### **G. CAMPAIGN REIMBURSEMENT PROCEDURES**

Recall R89898 claims should be submitted using the LONG FORM application only.

### **H. TECHNICIAN COMPETENCY REQUIREMENT**

The technician competency requirement for this campaign repair is: Level 1 - Quality Tech.

### **I. RETAILER ALLOWANCE (LONG FORM APPLICATION)**

**Claim Type:** R89898

**Cause Code:** 02

**CSC Code:** XW

**Main OP:** 99400

**Failed Part:** 31447982

### **INSPECTION**

<b>Operation Number</b>	<b>Repair Description</b>	<b>Qty</b>	<b>Labor Time</b>
99400	Inspect Both Rear Lock Strikers	1	0.1

### **INSTALLATION IF NEEDED**

<b>Operation Number</b>	<b>Repair Description</b>	<b>Qty</b>	<b>Labor Time</b>
97613	Install Rear Lock Striker(s)	1	0.7



## Volvo Car Customer Service

QB Instruction VCC-513520-1

<b>Title</b>	Backrest folding lock	<b>Page</b>	1 ( 10 )
<b>Action</b>	Installation	<b>Operation number:</b>	99400-2 97613-2

Issue	Date	Reason
1	2018-08	First issue

### Affected vehicles

Model year	Model
2019	XC40

### Materials

Materials	Qty.	Part No.	Notes
Flange nut	4.0	999127	
Lock brace	2.0	31447982	

**Orientation view**

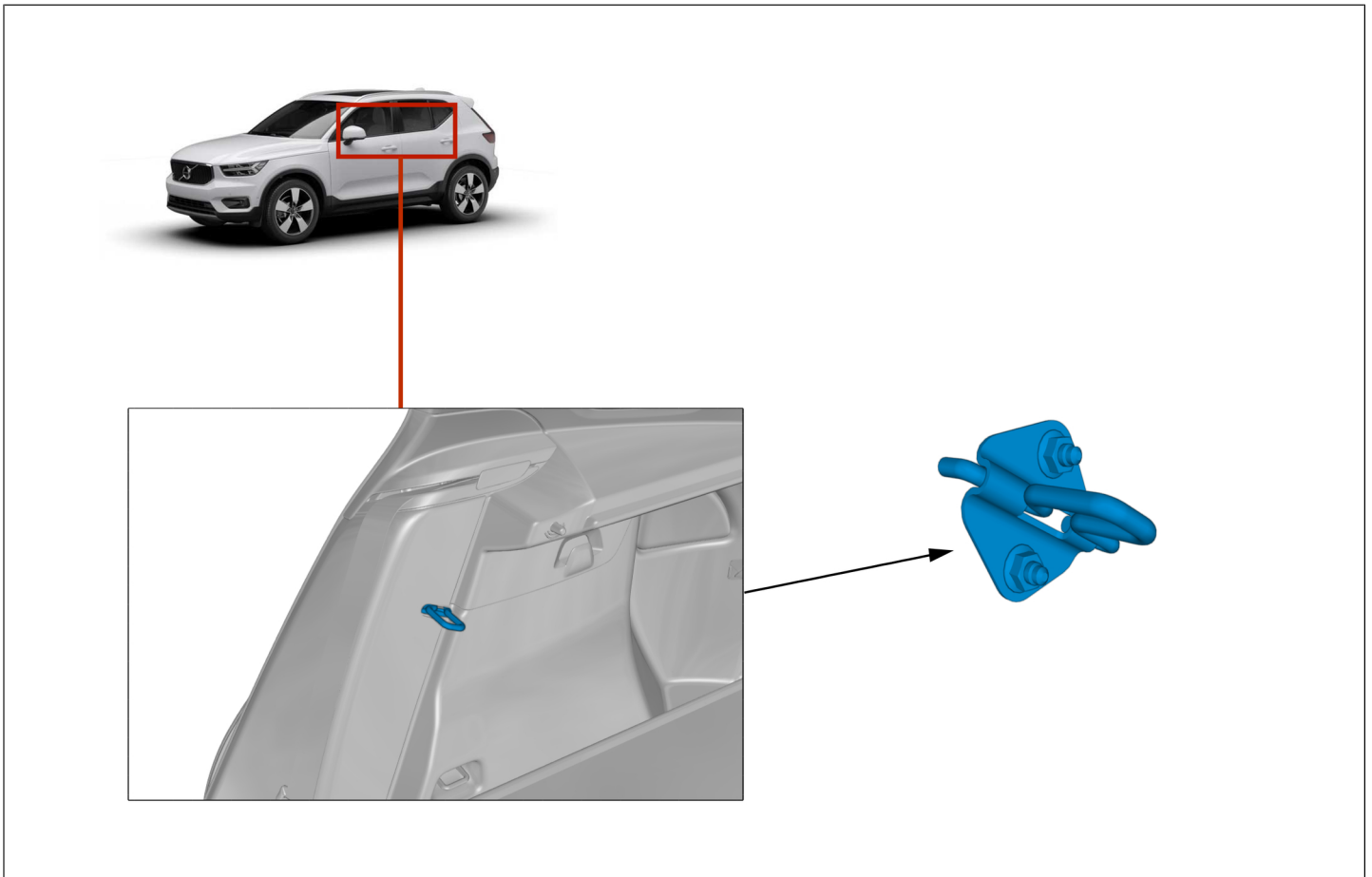

**Color symbols**

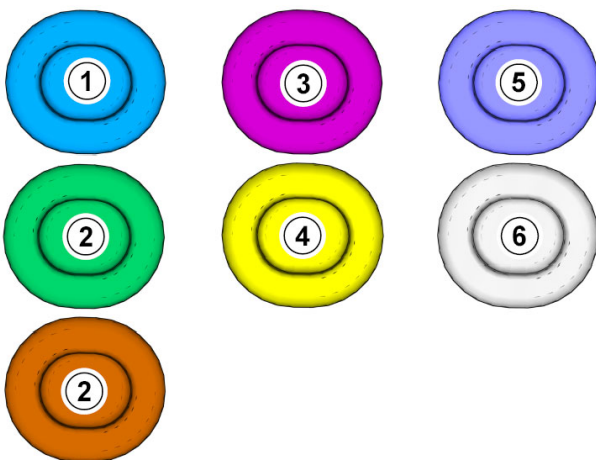

**Note! This colour chart displays (in colour print and electronic version) the importance of the different colours used in the images of the method steps.**

- 1 . Used for focused component, the component with which you will do something.
- 2 . Used as extra colors when you need to show or differentiate additional parts.
- 3 . Used for attachments that are to be removed/installed. May be screws, clips, connectors, etc.
- 4 . Used when the component is not fully removed from the vehicle but only hung to the side.
- 5 . Used for standard tools and special tools.
- 6 . Used as background color for vehicle components.

**Check**

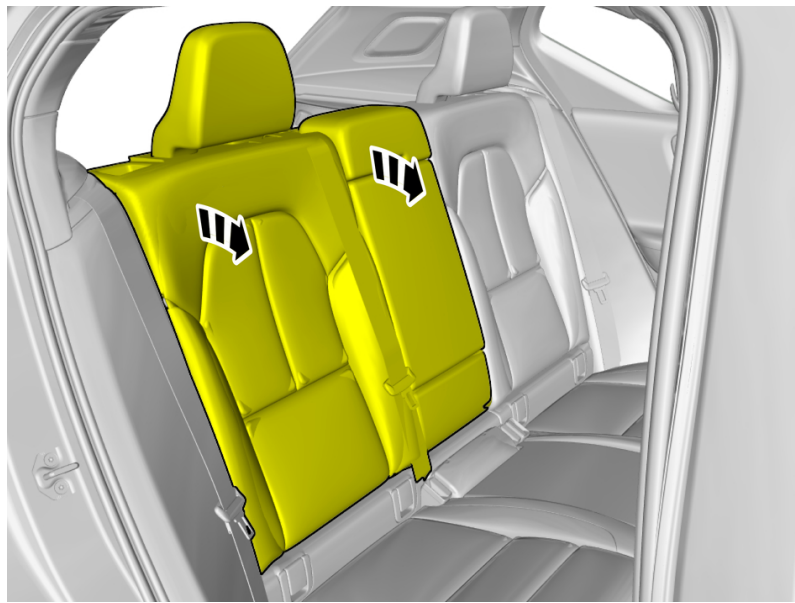

Fold marked part to one side.  
Repeat on the other side.

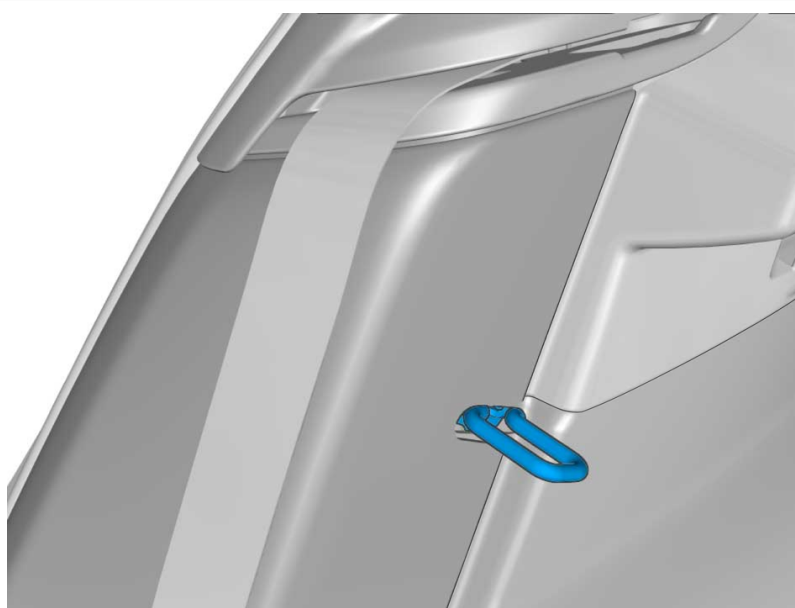

The graphic shows the correct design.  
On both sides.

Removal



Fold marked part to one side.

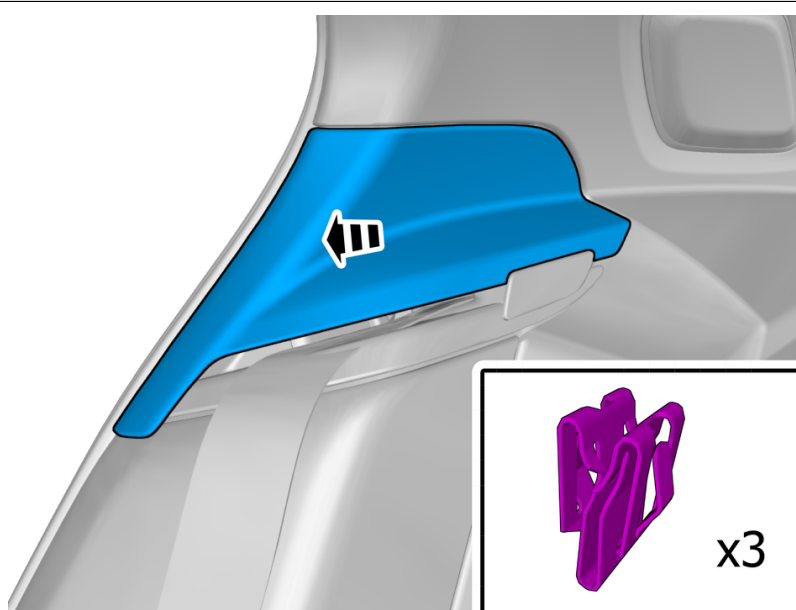

Remove the marked part.  
Use hands only.



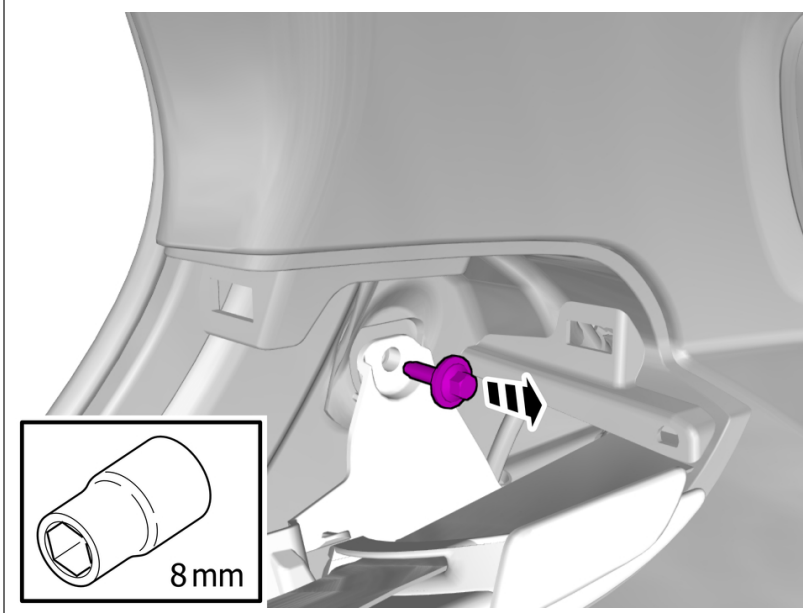

Remove the screw.

**Torque:**

Seat belt guide, to Bracket , 4.5 Nm

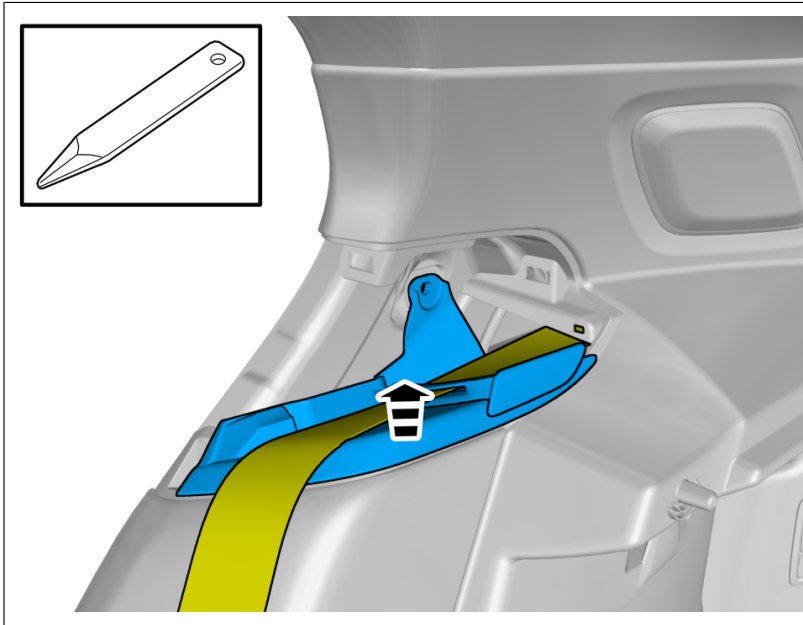

Remove the marked part.

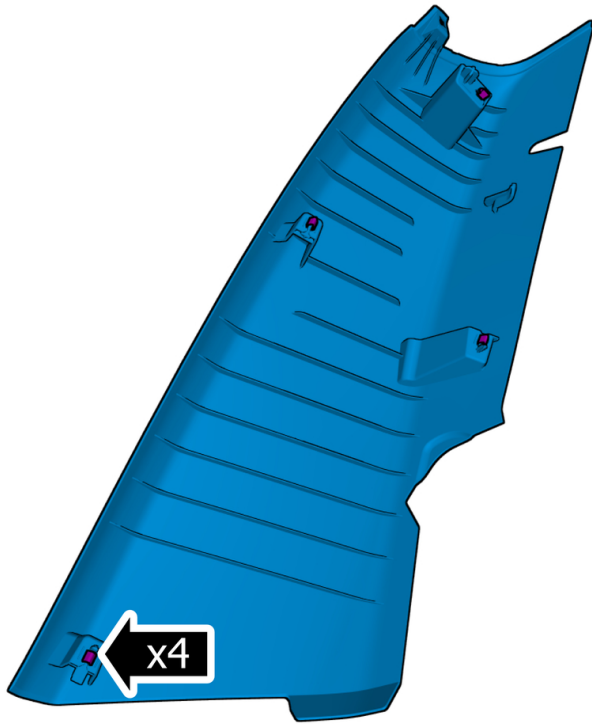

**Note!** The graphic shows the back of the component before removal.

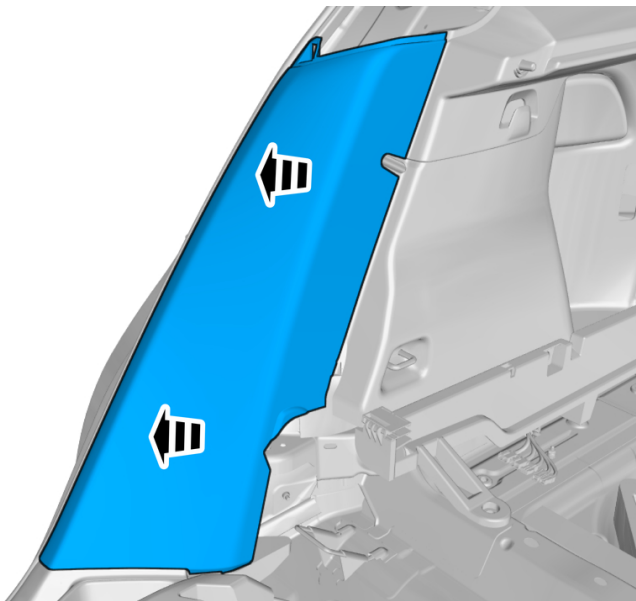

Remove the marked part.  
Use hands only.

Open the tailgate.



Loosen the marked detail.  
Repeat on the other side.

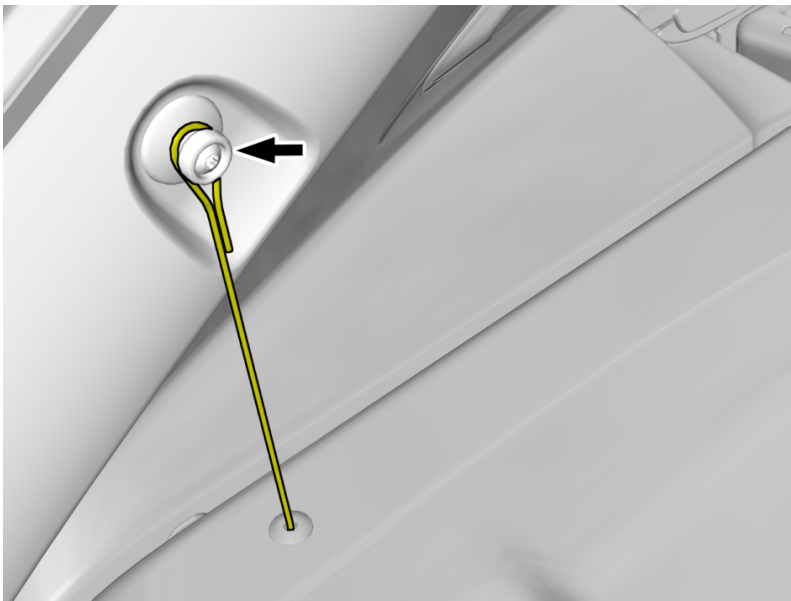

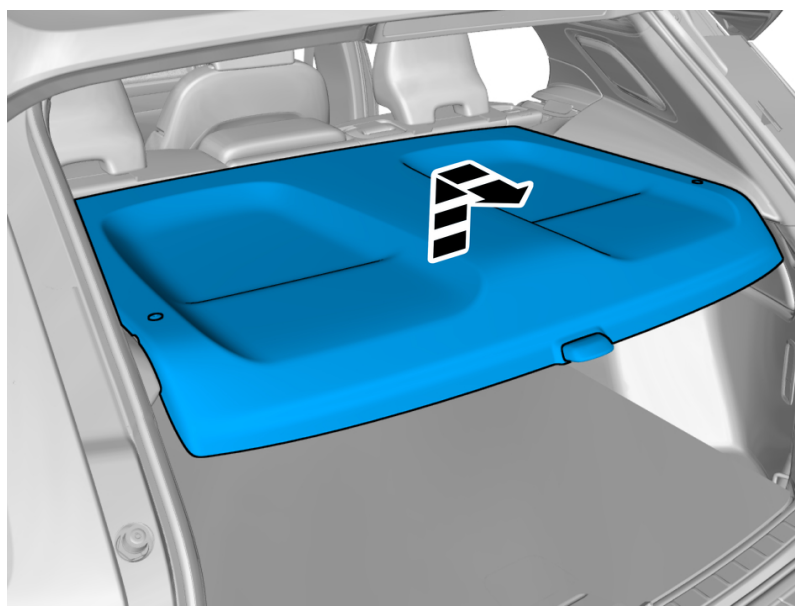

Remove the marked part.

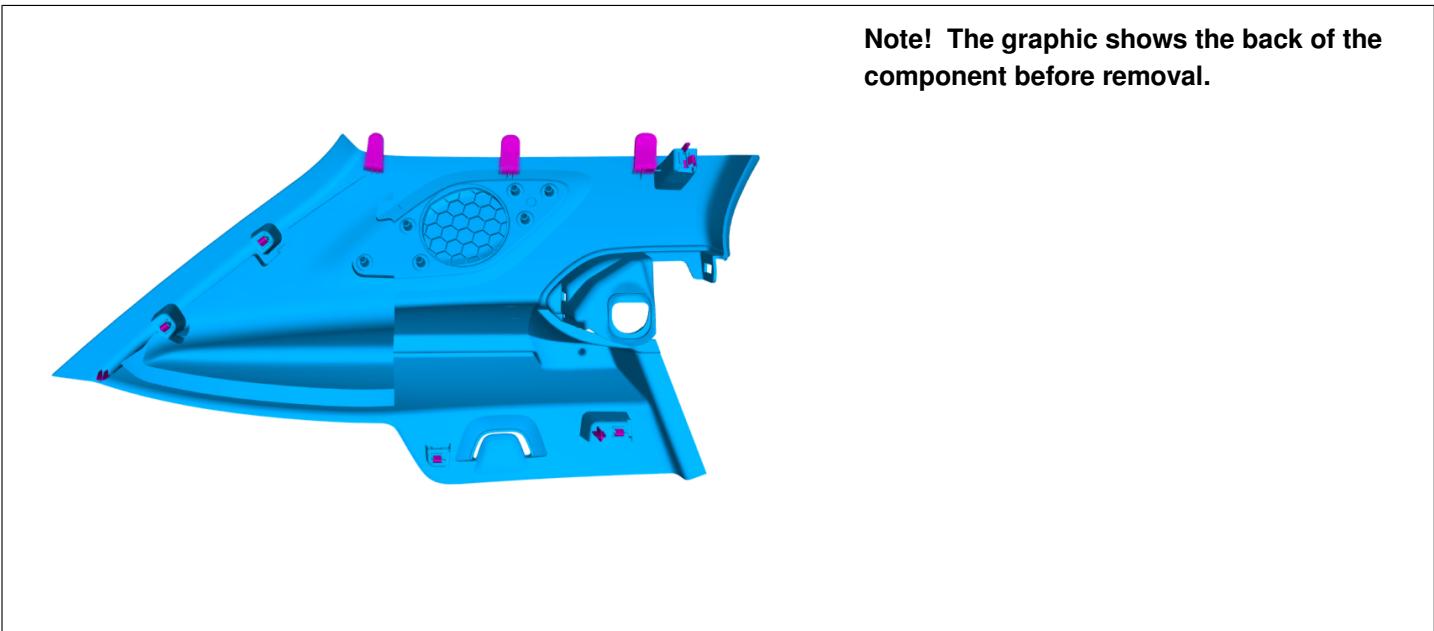

**Note!** The graphic shows the back of the component before removal.

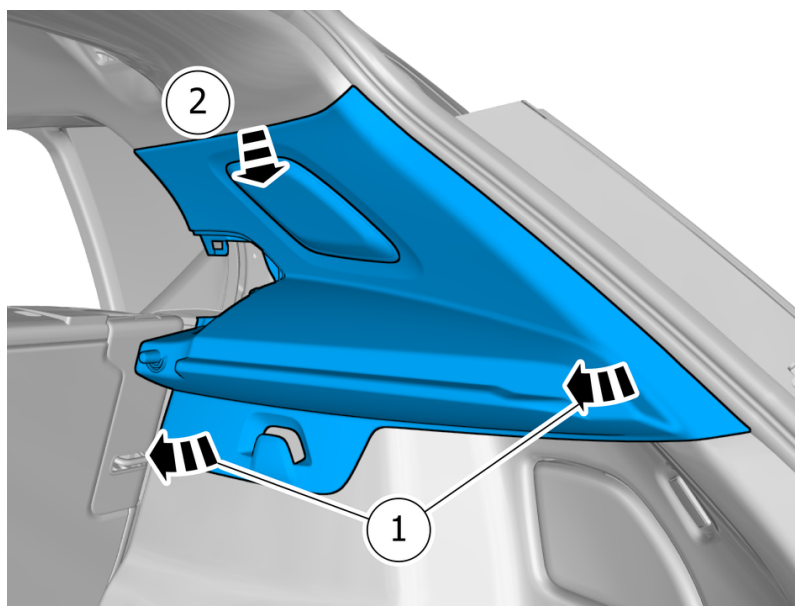

Remove the marked part.  
Use hands only.

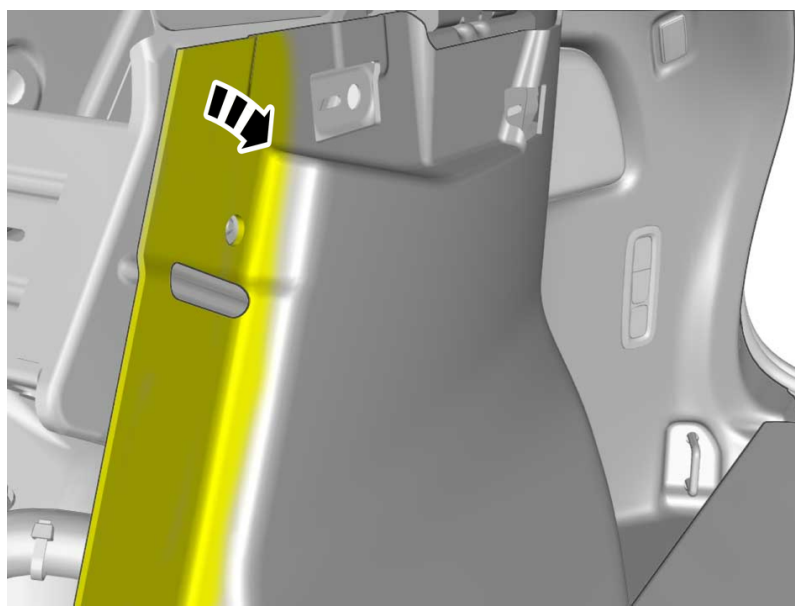

Fold marked part to one side.

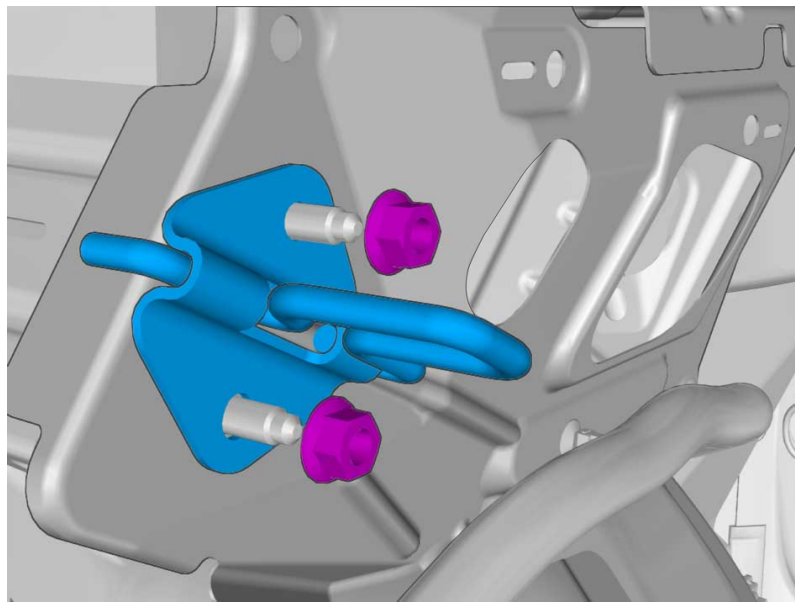
**Installation**

Install the marked component.  
Install the nuts

**Torque:**

M10 , 50 Nm

Repeat all method steps for the other side.

To install, reverse the removal procedure.

# PARTS BULLETIN

Subject: Recall R89898: Rear Seatback Lock Strikers	Group: 85	No: R89898
MY 2019 XC40	Market: US & CANADA	
		Date: 8/15/18

Reference Bulletin QB R89898

Volvo Car USA LLC and Volvo Car Canada LTD (Volvo) on behalf of Volvo Car Group has decided to launch Recall R89898 on a **limited** number of model year 2019 XC40 vehicles.

Volvo has identified that the rear seatback lock striker(s) may not have been installed when the vehicle was manufactured.

## **PLEASE NOTE**

The corrective action is to inspect the vehicle and verify that both rear seatback lock strikers are installed. If the seatback lock strikers are installed on the vehicle, no further action is necessary.

If one or both rear seatback strikers are missing, install them per the instructions below.

A total of 27 U.S. and 10 Canadian vehicles are eligible for this recall.

The following part numbers apply:

Part Number	Description	Qty
31447982	Lock brace (striker)	1 (each side)
999127	Flange nut	2 (each side)

## **IMPORTANT**

This recall involves a very limited number of vehicles.

Please order only after you have verified that you have a vehicle that requires these parts.



# SAFETY RECALL NOTICE

VOLVO CAR USA LLC  
PO Box 3757, Highland Park, MI 48203-9984

PRESORT  
FIRST-CLASS  
U.S. POSTAGE  
PAID  
VOLVO CAR



**YV4AC2HL6K777777**R89898D666666 523242-01 1

Volvo Owner  
12345 USin St.  
Any City, US 12345-6789



## IMPORTANT SAFETY RECALL INFORMATION



Issued in Accordance  
With Federal Law



October 12, 2018

**NHTSA RECALL 18V535**

### IMPORTANT SAFETY RECALL

**THIS NOTICE APPLIES TO YOUR VEHICLE, VIN: YV4AC2HL6K777777**

Dear Volvo Owner,

This notice is sent to you in accordance with the requirements of the National Traffic and Motor Vehicle Safety Act.

Volvo Car USA LLC (Volvo) on behalf of Volvo Car Group, has decided that a defect which relates to motor vehicle safety exists in certain model year 2019 XC40 vehicles.

#### The reason for Recall R89898:

Volvo has identified that on certain vehicles the rear seatback lock strikers may not have been installed during the manufacturing process. In the event of a crash, an unlocked seatback could increase the risk of injury to the seat occupants.

Your authorized Volvo retailer will inspect and if necessary install the rear seatback lock strikers.

#### What you need to do:

Please contact your authorized Volvo retailer for an appointment to complete this recall at **no cost to you**. The inspection procedure can take up to 10 minutes, and installation of the lock strikers if necessary can take up to 1.5 hours to complete. **However, the time your Volvo retailer requires to service your vehicle may be slightly longer depending on the vehicle.**

If you had previously paid for this repair to be performed, prior to receiving this letter, you may be eligible to receive reimbursement for the cost of obtaining a pre-notification remedy of the problem associated with this recall. For more information, please refer to the Volvo Customer Care Center contact information in this letter.

If you no longer own the vehicle described in this letter, please help us to update our records by sending us the updated owner information. Please refer to our contact information below.



***Please contact:***

If you have any questions, please contact your Volvo retailer. If your retailer is unable to answer your questions, please contact Volvo Customer Care Center:

1 Volvo Drive,  
P.O. Box 914,  
Rockleigh, NJ 07647

Or by phone at 1-800-458-1552, 24 hours a day, 7 days a week. You may also contact us by going to <http://volvo.custhelp.com/>.

We have advised the National Highway Traffic Safety Administration (NHTSA) that we are conducting this recall. If you are unable to have this procedure performed without charge, and within a reasonable period of time, you may contact the NHTSA Administrator at:

National Highway Traffic Safety Administration  
1200 New Jersey Avenue, SE.  
Washington, DC 20590

Or you can call the toll-free Vehicle Safety Hotline at 1-888-327-4236 (TTY: 1-800-424-9153). You may also go to their website, <http://www.safercar.gov>.

Federal law requires that any vehicle lessor receiving this recall notice must forward a copy of this notice to the lessee within ten days.

Your safety and continued satisfaction with your Volvo and the Volvo organization are very important to us. We apologize for any inconvenience this may cause, and we appreciate your cooperation in arranging to have this important service completed as quickly as possible.

Sincerely,

A handwritten signature in blue ink that reads "Bill Casey". The signature is written in a cursive style.

Bill Casey  
Director Customer Care