



Service Bulletin

File in Section: -

Bulletin No.: 17-NA-153

Date: December, 2018

INFORMATION

Subject: Operating Tips for Hands Free Liftgate

This Bulletin replaces PIT5472A. Please discard PIT5472A.

Brand:	Model:	Model Year:		VIN:		Engine:	Transmission:
		from	to	from	to		
Buick	Enclave	2018	2019			All	All
	Envision	2017					
Cadillac	CT6	2016					
	Escalade Models	2015					
	XT5	2017					
Chevrolet	Blazer	2019					
	Suburban	2015					
	Tahoe Models						
	Traverse	2018					
	Equinox						
GMC	Yukon Models	2015					
	Terrain	2018					

Involved Region or Country	North America and N.A. Export Regions
Additional Options	Equipped with Hands-Free Power Liftgate (RPO TC2)
Condition	In some cases, customers may experience problems with the activation of the liftgate hands-free operation. Note: This feature may be temporarily disabled under some conditions (example: after several hands free opening and closing events in a row). If the liftgate does not respond to the kick, open and close the liftgate by another method (button on overhead console, RKE fob button, etc) or start the vehicle and the feature will be re-enabled.
Correction	Below are a few operating tips to help better understand how to best operate the hands free liftgate feature.

Parts Information

No parts are needed for this condition.

Tips to Help Understand How to Best Operate the Hands Free Liftgate Feature

- The RKE Fob must be within the detection area, which is 3 ft (1 m) of the rear bumper.



4782690

Important: Models: Cadillac Escalade; Chevrolet Suburban, Tahoe and GMC Yukon



4782691

Important: Models: Cadillac CT6



4782692

Important: Models: Cadillac XT5 and GMC Acadia



4782693

Important: Models: Buick Enclave, Envision; Chevrolet Traverse, Equinox, Blazer and GMC Terrain

- Best operation will occur when the foot kick is conducted at the direct center of the kick zone. See the illustrations above for models kick zone.



4782695

- To operate, kick your foot straight up in one swift motion under the center of the rear bumper, then pull it back. There are two antennas located in the rear bumper fascia that must be triggered for the system to detect a kick. During the kick, your foot and shin must come within 6.5 inches (16.5 cm) of the rear fascia for both antennas to be triggered and detect the kick.
- Speed of kick should be 1 second or less.

Projected Logo

If equipped with this feature, a vehicle logo will be projected for one minute onto the ground near the rear bumper when an RKE transmitter is detected within approximately 2 m (6 ft).

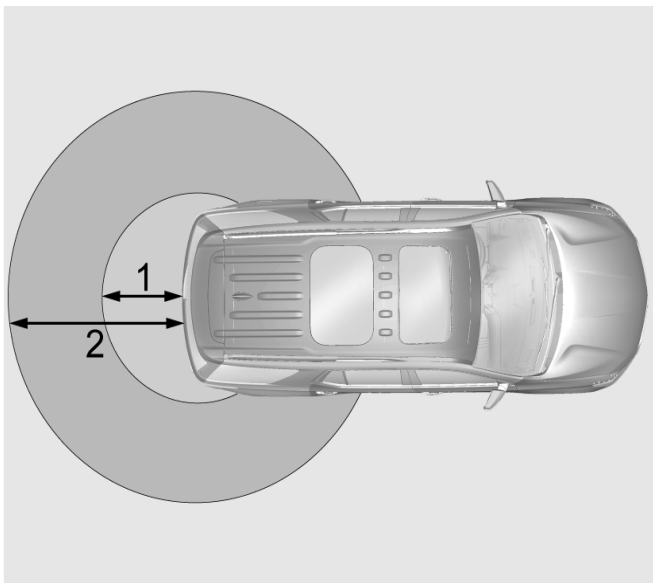

4773572

- 1 m (3 ft) Hands-Free Operation Detection Zone
- 2 m (6 ft) Projected Logo Detection Zone

The projected logo shows where the kicking motion is to take place.

The projected logo will only be available for this RKE transmitter after it has been out of range for at least 20 seconds.

If an RKE transmitter is again detected within approximately 2 m (6 ft) of the liftgate, or another hands-free operation has been detected, the one-minute timer will be reset.

The projected logo will not work under the following conditions:

- The vehicle battery is low.
- The transmission is not in P (Park).
- Hands Free Liftgate Operation is set to OFF in vehicle personalization. See Vehicle Personalization.
- Power liftgate is turned off.
- The vehicle remains parked for 72 hours or more, with no RKE transmitter use or Keyless Access operation. To re-enable, press any button on the RKE transmitter or open and close a vehicle door.

The projected logo will not work for a single RKE transmitter when a transmitter:

- Has been left within approximately 5 m (15 ft) of the liftgate for several minutes.
- Has been left inside the vehicle and all vehicle doors are closed.
- Has approached the area outside of the liftgate five times within 10 minutes.

Hands Free Liftgate and Projected Logo Availability

Action	Hands-Free Liftgate	Projected Logo
RKE Transmitter within detection zone	Operative	On for 1 minute
RKE Transmitter left inside detection zone for minimum 10 minutes	Operative	On for 1 minute Off until RKE button press or a door is opened and closed
RKE Transmitter brought in and out of detection zone 5 times within 10 minutes	Operative	On for 1 minute Off for 1 hour or until RKE button press or door is opened and closed
Vehicle remains parked for more than 72 hours	Operative	Off
Vehicle battery is low	Non-operative	Off

Hands Free Liftgate and Projected Logo Availability (cont'd)

Action	Hands-Free Liftgate	Projected Logo
Transmission is not in P (Park)	Non-operative	Off
Power Liftgate is turned off	Non-operative	Off
Hands-Free Liftgate is disabled	Non-operative	Off

Tips to Avoid to Ensure Best Operation

- Do NOT sweep your foot from side to side.
- Do NOT keep your foot under the bumper.
- Do NOT touch the liftgate until it stops moving.

Caution: The liftgate may open or close if: cleaning or working near the rear bumper, splashing water, stepping into the liftgate opening, etc. To avoid this, keep the RKE fob away from the rear bumper detection area or turn the liftgate mode switch to Off.

Note: If a customer of a 2015/2016 Chevrolet Tahoe/Suburban has a concern of the hands free liftgate feature being too sensitive or activates too easily, see the latest version of PIT5531 for updated calibrations.

Version	2
Modified	December 13, 2018 – Added the 2019 Model Year and Blazer model and corrected CT6 first model year.

