

1 12 08-18



## Service Information Bulletin

SUBJECT	DATE
Symptom Diagnostics - Oil Present at the Turbocharger Compressor Housing	December 2018

### Additions, Revisions, or Updates

Publication Number / Title	Platform	Section Title	Change
DDC-SVC-MAN-0084	DD Platform	Symptom Diagnostics - Oil Present at the Turbocharger Compressor Housing	This is the same procedure as the GHG17 with one photo removed and should replace the current procedure in the 0084 manual.



13400 Outer Drive, West, Detroit, Michigan 48239-4001  
 Telephone: 313-592-5000  
[www.demanddetroit.com](http://www.demanddetroit.com)

## 2 Symptom Diagnostics - Oil Present at the Turbocharger Compressor Housing

Note: Some oil residue at the turbocharger compressor housing is acceptable (See figure 1 below). This residue may look like a soot coating on the compressor housing and will be dry to touch. This residue occurs over a long period of time usually in combination with high idle time.



Excessive oil (See figure 2 below) in the turbocharger compressor housing will be wet to touch and can be present from a number of different failure modes;

- High Air Intake restriction
- Boost leaks
- High crankcase pressure
- Obstructed turbo oil drain
- Failed turbo

If the failure mode is one other than a failed turbo, once repaired the turbocharger will no longer pass oil.

If it is uncertain whether the compressor housing is acceptable or excessive, complete the following diagnostics. Do NOT replace the turbocharger without completing the following diagnostics.

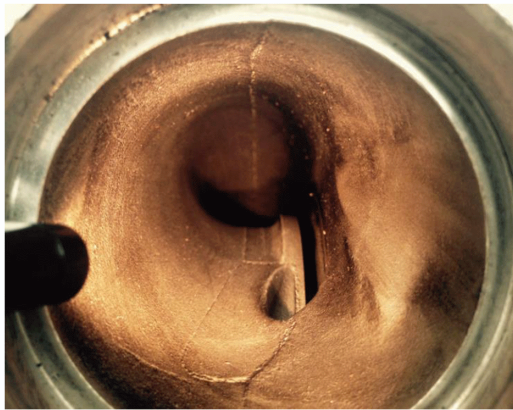
**Table 1.**

 <p style="text-align: center;"><b>1</b></p> <p style="text-align: right;">d090127a</p>	 <p style="text-align: center;"><b>2</b></p> <p style="text-align: right;">d090127b</p>
1. Acceptable oil in the turbocharger compressor housing	2. Excessive oil in the turbocharger compressor housing

Check as follows:

1. Apply the parking brake, chock the wheels, and perform any other applicable safety steps.
2. Inspect the Turbocharger.
  - For DD15 and DD16 : Refer to section "Inspection of the DD15 and DD16 Turbocharger". Is the turbocharger visually damaged?
  - For DD13 : Refer to section "Inspection of the DD13 Turbocharger" . Is the turbocharger visually damaged?
    - a. Yes; clean out air systems and replace the turbocharger.
    - b. No; Go to step 3.
3. Connect Diagnostic Link®.

4. Inspect for any active fault codes. Are any fault codes active?
  - a. Yes; perform troubleshooting for active fault code(s).
  - b. No; Go to step 5.
5. Inspect the hood cowl for any debris that may cause a high air intake restriction (ice buildup, leaves, dirt, etc). Was an obstruction found?
  - a. Yes; clean out all debris/obstructions found in hood cowl. Clean out air systems and Go to step 11.
  - b. No; Go to step 6.
6. Visually inspect the air filter. Is the air filter wet/plugged/obstructed?
  - a. Yes; replace the air filter. Clean out air systems and Go to step 11.
  - b. No; reinstall the air filter and Go to step 7.
7. Check for air system leaks from the turbo compressor to the intake manifold. Were air system leaks found?
  - a. Yes; Repair leak(s) as necessary. Clean out air systems and Go to step 11.
  - b. No; Go to step 8.
8. Perform a crankcase pressure test. Refer to section "Crankcase Pressure Test" . Is crankcase pressure in range?
  - a. Yes; Go to step 9.
  - b. No; Repair cause of excessive crankcase pressure, clean out all air systems, and Go to step 11.

**NOTE:** The turbo drain pipe gasket can cause an obstruction if installed incorrectly.

9. Remove and inspect the turbo oil drain pipe (1) and cylinder block for damage/restrictions. Was damage/restrictions found?

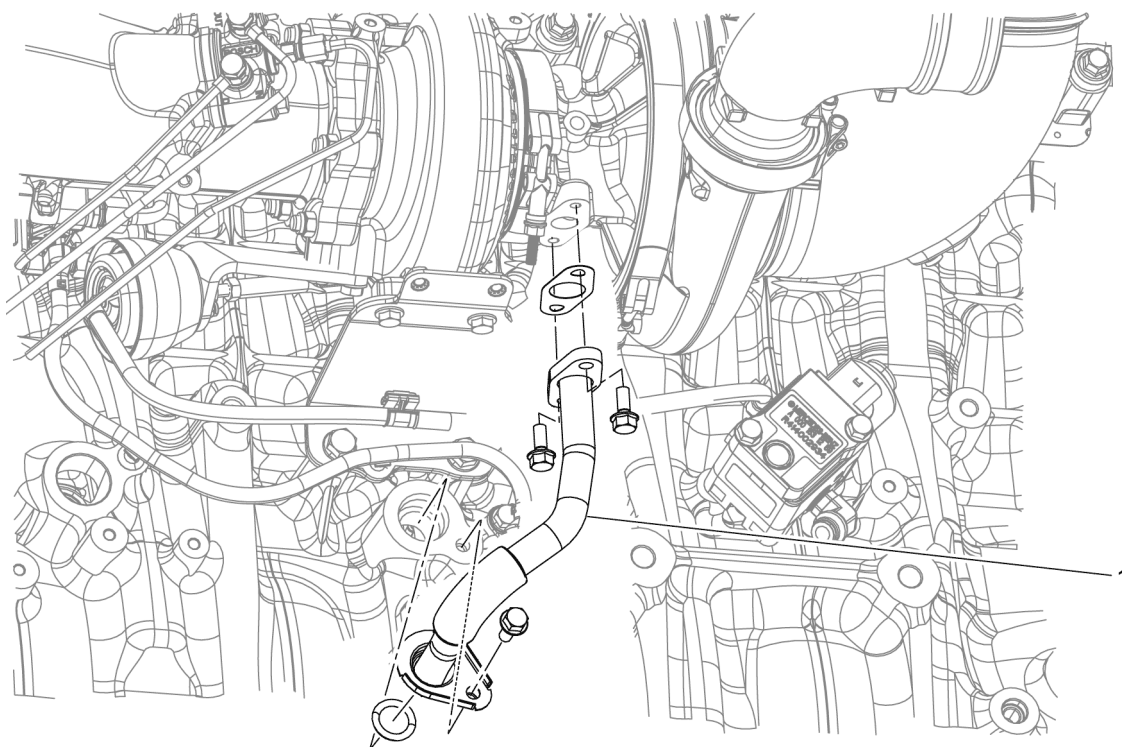

d090102a

- a. Yes; replace turbo oil drain pipe (See figure above (1)). Clean out all air systems and Go to step 11.
- b. No; Go to step 10.

**NOTE:** The Turbocharger is a non-serviceable part. Do not remove the compressor housing for cleaning.

10. Clean the inside of the turbocharger compressor elbow (1) .

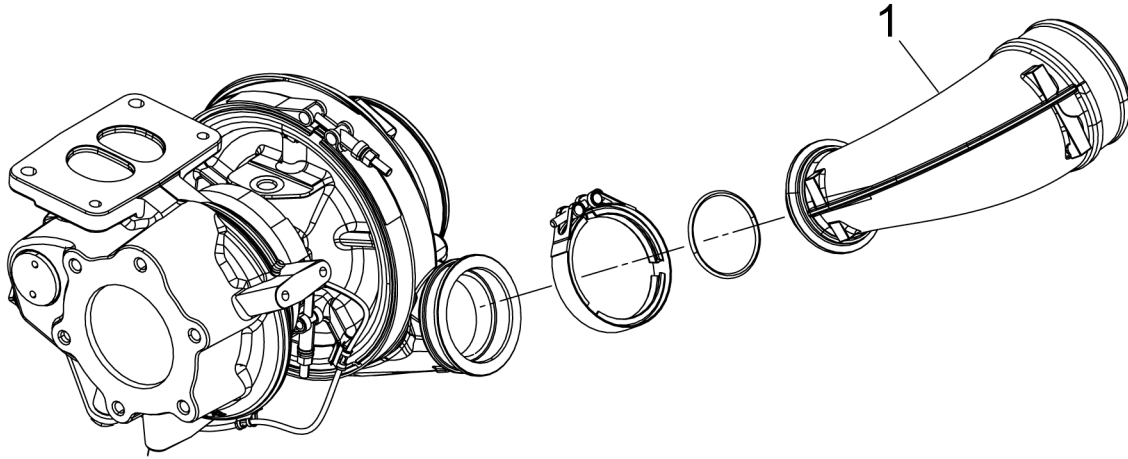

d090126

11. Warm up the engine until oil temperature reaches 60°C (140°F).



**WARNING: PERSONAL INJURY**

Diesel engine exhaust and some of its constituents are known to the State of California to cause cancer, birth defects, and other reproductive harm.

- Always start and operate an engine in a well ventilated area.
- If operating an engine in an enclosed area, vent the exhaust to the outside.
- Do not modify or tamper with the exhaust system or emission control system.



**WARNING: PERSONAL INJURY**

To avoid injury before starting and running the engine, ensure the vehicle is parked on a level surface, parking brake is set, and the wheels are blocked.



**WARNING: PERSONAL INJURY**

To avoid injury, never remove any engine component while the engine is running.





**WARNING: PERSONAL INJURY**

To avoid injury from hot surfaces, wear protective gloves, or allow engine to cool before removing any component.

12. Run the engine at 900 rpm for 20 minutes. Is oil present in the previously cleaned turbocharger compressor elbow ?

Table 2.

 <p style="text-align: center;"><b>1</b></p> <p style="text-align: right;">d090128a</p>	 <p style="text-align: center;"><b>2</b></p> <p style="text-align: right;">d090128b</p>
1. Clean - no oil passing	2. Oil passing after cleaning

- a. Yes; replace turbocharger. Clean out all air systems .
- b. No; release unit.