

SERVICE ACTION

Reference number:	SA-06-1185	Issued: 05 November, 2018
Subject:	DBS Superleggera Rear Brake Check	
Model(s):	DBS Superleggera	
VIN range:	Refer to the separately published list of affected Vehicle Identification Numbers (VINs)	
Applicable to:	All Dealers	
Distribute to:	After Sales Manager Service Manager Sales Manager	Warranty Staff Technician(s) Parts Staff

Reason for this Service Action

Aston Martin has identified a quantity of DBS Superleggera vehicles that have incorrect rear brake pads or rear brake calipers fitted. To identify if a vehicle has incorrect rear brake pads or rear brake calipers fitted, refer to the parts that follow:

- Part A – Inspect the rear brake calipers
- Part B – Inspect the rear brake pads
- Part C – Inspect the rear brake hoses

Part A – Inspect the rear brake calipers

1. Remove the rear wheels (refer to Workshop Manual procedure 04.04.ED).
2. Visually inspect the rear brake caliper to make sure the correct brake caliper is installed.

Figure 1 shows the incorrect rear brake caliper that does not include an alignment hole.

Figure 2 shows the correct rear brake caliper that includes an alignment hole.



Figure 1



Figure 2

3. Make sure that the brake caliper is installed correctly. The bleed nipple must be located at the top of the rear brake caliper (refer to Figure 3).

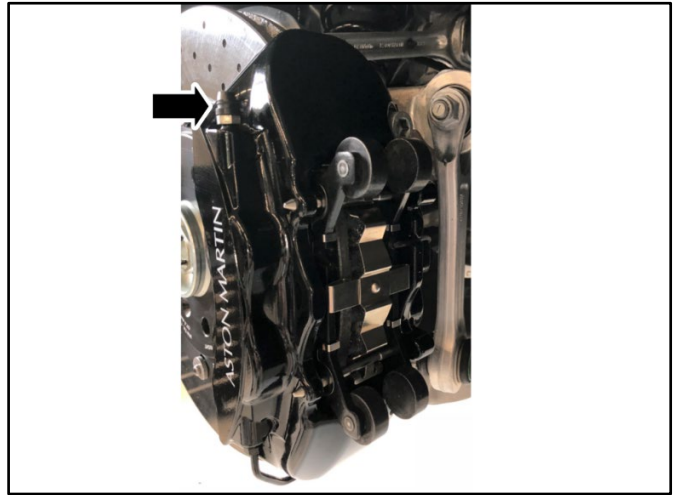

Figure 3

4. If the correct rear brake calipers are installed, go to Part B – Inspect the rear brake pads.
5. If an incorrect caliper is installed the caliper must be replaced (Refer to Workshop Manual procedure (06.04.AB or 06.04.AC).
6. If an the correct caliper is used, but installed incorrectly, the caliper must be removed and installed correctly (refer to Workshop Manual procedure (06.04.AB or 06.04.AC).

Part B – Inspect the rear brake pads

1. Visually inspect the rear brake calipers to make sure the correct brake pads are installed.
Figure 4 shows the incorrect rear brake pads.
Figure 5 shows the correct rear brake pads which are identified by the larger weights.

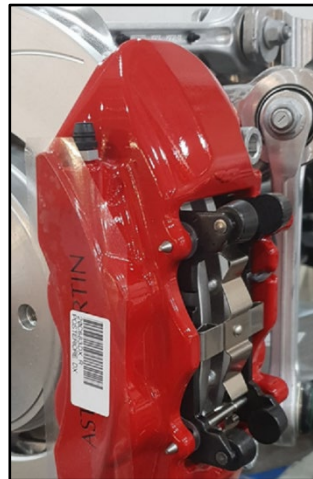

Figure 4



Figure 5

2. If the incorrect rear brake pads are installed, the rear brake pads must be replaced (Refer to Workshop Manual procedure 06.04.AD).

Part C – Inspect the rear brake hoses

1. Visually inspect the rear brake hoses to make sure that the hoses are not twisted.

Figure 6 shows a twisted rear brake hose viewed from above.

Figure 7 shows a correctly installed rear brake hose viewed from above.



Figure 6



Figure 7

2. If the rear brake hoses are twisted, do the Rear Brake Pipe **Workshop Procedure**.
3. If the rear brake hose is not twisted, no further action is required.

Rear Brake Pipe Workshop Procedure

1. Undo the union for the brake line (refer to Figure 8).

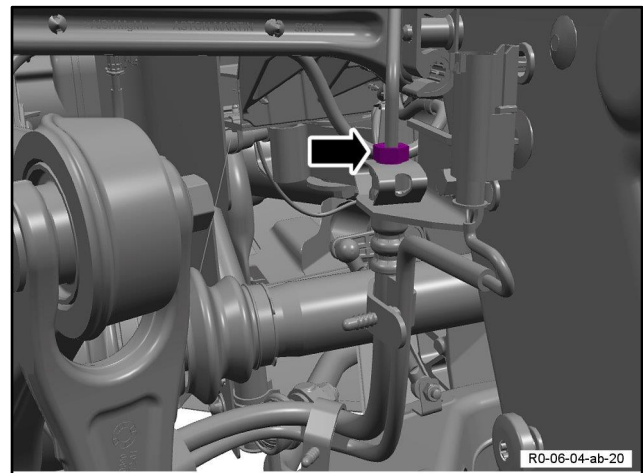

Figure 8

CAUTION: DO NOT BEND THE BRAKE LINE. THIS WILL HELP PREVENT DAMAGE TO THE BRAKE LINE.

2. Release the brake line (refer to Figure 9).

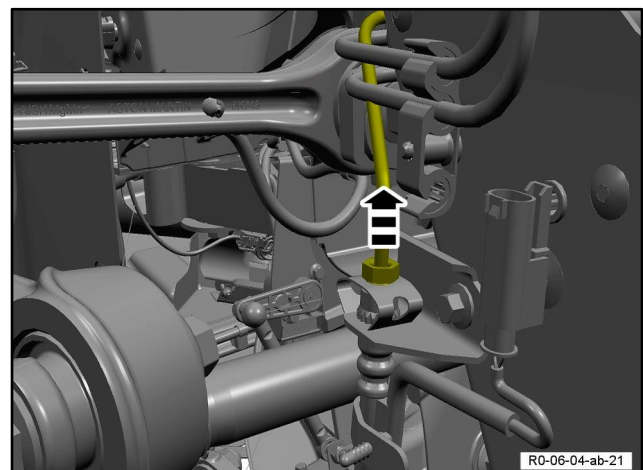

Figure 9

3. Remove the clip that attaches the brake hose to the bracket (refer to Figure 10).

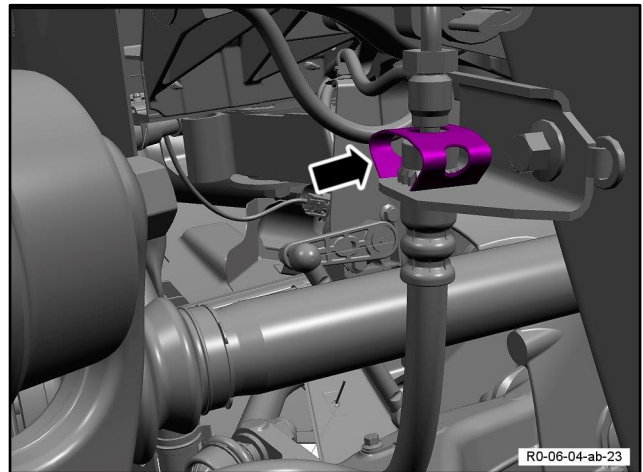

Figure 10

4. Turn the hose so that the splines align and release it from bracket (refer to Figure 11).

Note: *Install the applicable caps to seal the open ports.*

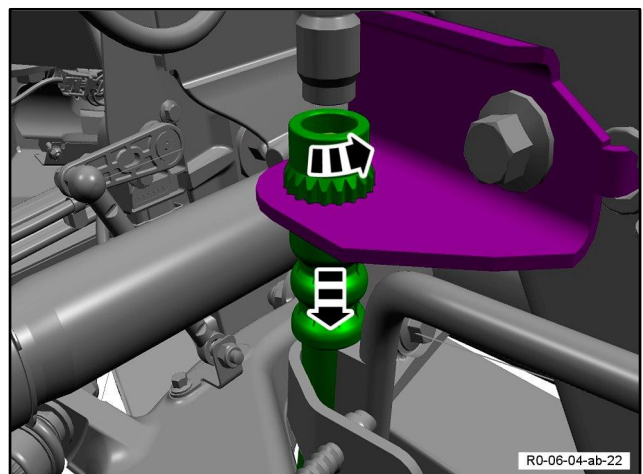

Figure 11

5. Correctly install the rear brake hose.
6. Do steps 1 thru to 4 in the opposite order.

Note: *Only do step 7 after you have inspected and adjusted both rear brake hoses.*

7. Bleed the brake system (refer to Workshop Manual procedure 06.07.DD).

Part Data

Description	Part Number	Quantity
Brake Fluid	700781-PK	As required
Kit, Brake Pads	KY73-2C562-AA	1
Kit, Springs and Pins	KY73-2C588-BA	1
Caliper, Rear Brake, LH (Grey, Less Pads)	KY73-2E465-AA	As required
Caliper, Rear Brake, LH (Black, Less Pads)	KY73-2E465-CA	As required
Caliper, Rear Brake, LH (Red, Less Pads)	KY73-2E465-DA	As required
Caliper, Rear Brake, LH (Yellow, Less Pads)	KY73-2E465-FA	As required
Caliper, Rear Brake, LH (Blue, Less Pads)	KY73-2E465-GA	As required
Caliper, Rear Brake, LH (Madagascar Orange, Less Pads)	KY73-2E465-HA	As required
Caliper, Rear Brake, LH (Anodised Black, Less Pads)	KY73-2E465-JA	As required
Caliper, Rear Brake, LH (Gulf Orange Less Pads)	KY73-2E465-KA	As required
Caliper, Rear Brake, LH (Bronze, Less Pads)	KY73-2E465-MA	As required
Caliper, Rear Brake, LH (Lime, Less Pads)	KY73-2E465-NA	As required
Caliper, Rear Brake, LH (Vivid Blue, Less Pads)	KY73-2E465-PA	As required
Caliper, Rear Brake, LH (Satin Silver, Less Pads)	KY73-2E465-RA	As required
Caliper, Rear Brake, LH (Vivid Red, Less Pads)	KY73-2E465-SA	As required
Caliper, Rear Brake, RH (Grey, Less Pads)	KY73-2E464-AA	As required
Caliper, Rear Brake, RH (Black, Less Pads)	KY73-2E464-CA	As required
Caliper, Rear Brake, RH (Red, Less Pads)	KY73-2E464-DA	As required
Caliper, Rear Brake, RH (Yellow, Less Pads)	KY73-2E464-FA	As required
Caliper, Rear Brake, RH (Blue, Less Pads)	KY73-2E464-GA	As required
Caliper, Rear Brake, RH (Madagascar Orange, Less Pads)	KY73-2E464-HA	As required
Caliper, Rear Brake, RH (Anodised Black, Less Pads)	KY73-2E464-JA	As required
Caliper, Rear Brake, RH (Gulf Orange Less Pads)	KY73-2E464-KA	As required
Caliper, Rear Brake, RH (Bronze, Less Pads)	KY73-2E464-MA	As required
Caliper, Rear Brake, RH (Lime, Less Pads)	KY73-2E464-NA	As required
Caliper, Rear Brake, RH (Vivid Blue, Less Pads)	KY73-2E464-PA	As required
Caliper, Rear Brake, RH (Satin Silver, Less Pads)	KY73-2E464-RA	As required
Caliper, Rear Brake, RH (Vivid Red, Less Pads)	KY73-2E464-SA	As required
Bolt, M12-95 (ALWAYS REPLACE, DO NOT RE-USE)	8D33-2C564-AA	4

Warranty Data**Procedure and Labour Time**

Description	Labour Time	Tier
Rear Brake Caliper, Left Side (Inspect Only)	0.35 hours	A
Rear Brake Caliper, Left Side (Remove and Refit Existing Part)	1.5 hours	A
Rear Brake Caliper, Right Side (Inspect Only)	0.35 hours	B
Rear Brake Caliper, Right Side (Remove and Refit Existing Part)	1.5 hours	B
Rear Brake Caliper, Left Side & Right Side (Inspect Only)	0.35 hours	C
Rear Brake Caliper, Left Side & Right Side (Remove and Refit Existing Part)	3 hours	C
Rear Brake Caliper, Right Side (Inspect Only)	0.35 hours	D
Rear Brake Caliper, Right Side (Install New Part)	1.5 hours	D
Rear Brake Caliper, Let Side (Inspect Only)	0.35 hours	E
Rear Brake Caliper, Left Side (Install New Part)	1.5 hours	E
Rear Brake Caliper, Left Side & Right Side (Inspect Only)	0.35 hours	F
Rear Brake Caliper, Left Side & Right Side (Install New Parts)	3.0 hours	F
Rear Brake Pads, Left Side (Inspect Only)	0.35 hours	G
Rear Brake Pads, Left Side (Install New Part)	0.7 hours	G
Rear Brake Pads, Right Side (Inspect Only)	0.35 hours	H
Rear Brake Pads, Right Side (Install New Part)	0.7 hours	H
Rear Brake Pads, Left Side & Right Side (Inspect Only)	0.35 hours	J
Rear Brake Pads, Left Side & Right Side (Install New Parts)	1.4 hours	J
Rear Brake Hose, Left Side (Inspect Only)	0.35 hours	K
Rear Brake Hose, Left Side (Remove and Refit)	1 hours	K
Rear Brake Hose, Right Side (Inspect Only)	0.35 hours	L
Rear Brake Hose, Right Side (Remove and Refit)	1 hours	L
Rear Brake Hose, Left Side & Right Side (Inspect Only)	0.35 hours	M
Rear Brake Hose, Left Side & Right Side (Remove and Refit)	2 hours	M

Warranty Claim Information

Note: *Please note that only 1 Tier can be claimed. Submission and Acceptance of a claim will close all other Tiers applicable to the chassis number.*

If a rear brake caliper has to be replaced in Tiers D, E or F, select 'Inspect and Repair' and tick the 'Consequential Parts' box of the claim form.

If rear brake pads have to be replaced in Tiers E, F or G and the procedure to untwist brake hoses is also necessary, you can claim for the labour time to untwist the hoses in the 'Lab Hrs Additional' field on the claim form.

If you have any questions related to this Service Action, please contact: Aston Martin Technical Services
on: +44 (0) 1926 644720, email: askamtech@astonmartin.com,
or contact your After Sales Manager.

The English version of this Service Action is written in
Simplified Technical English to ASD-STE100™.