

SERVICE ACTION

Reference number:	SA-03-1136	Issued: 23 November, 2018
Subject:	Sound Regulator Air Leak	
Model(s):	Vantage (19MY)	
VIN Range:	Refer to the separately published list of affected Vehicle Identification Numbers (VINs)	
Applicable to:	All Dealers	
Distribute to:	After Sales Manager Executive Manager Service Manager Sales Manager	Warranty Staff Technician(s) Parts Staff

Reason for this Service Action

On some Vantage 19MY vehicles, it is possible that an air leak can occur from the sound regulator. This can cause Diagnostic Trouble Codes (DTC's) and reduced engine performance. To remove and repair the sound regulator do the Workshop Procedure that follows:

Workshop Procedure

1. Disconnect the vehicle battery (refer to Workshop Manual procedure 14.01.CA).
2. Remove the four bolts that attach the fuse boxes to the vehicle (refer to Figure 1).

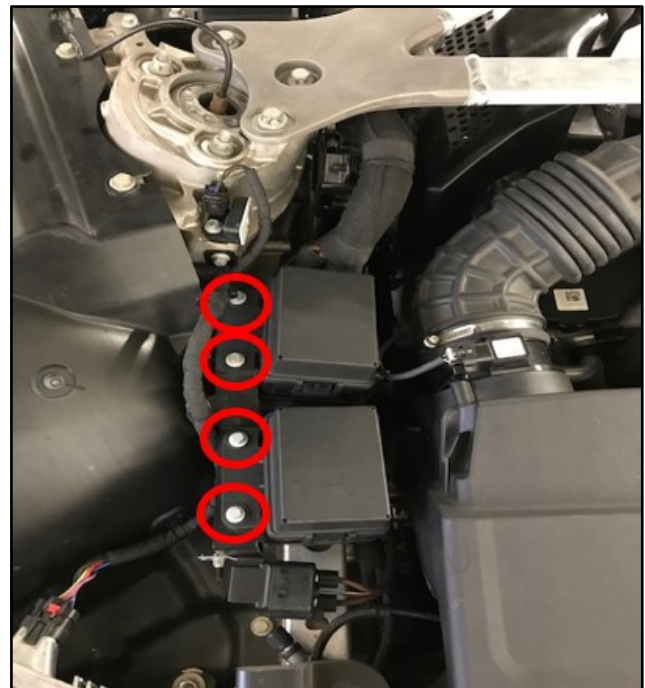

Figure 1

3. Move the fuse boxes to get access to the hose for the sound regulator (refer to Figure 2).



Figure 2

4. Remove the bolt that attaches the adaptor and hose to the sound regulator (refer to Figure 3).

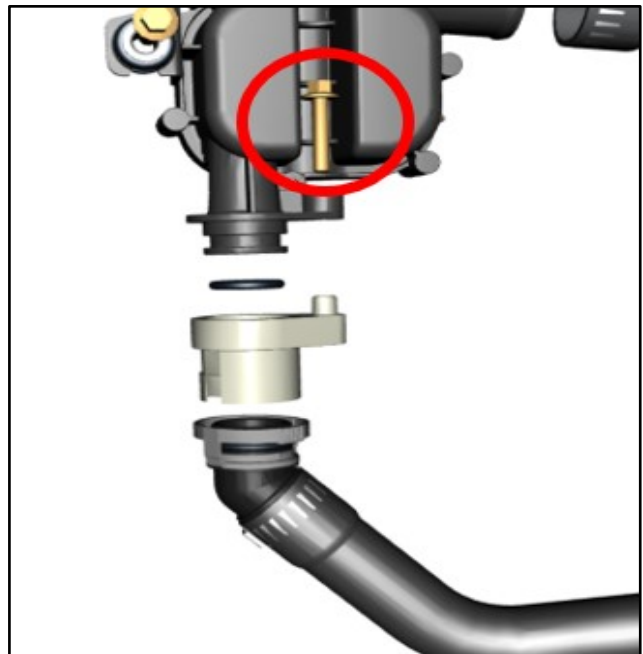

Figure 3

5. Release the hose from the sound regulator (refer to Figure 4).



Figure 4

6. Disconnect the adaptor from the hose (refer to Figure 5).

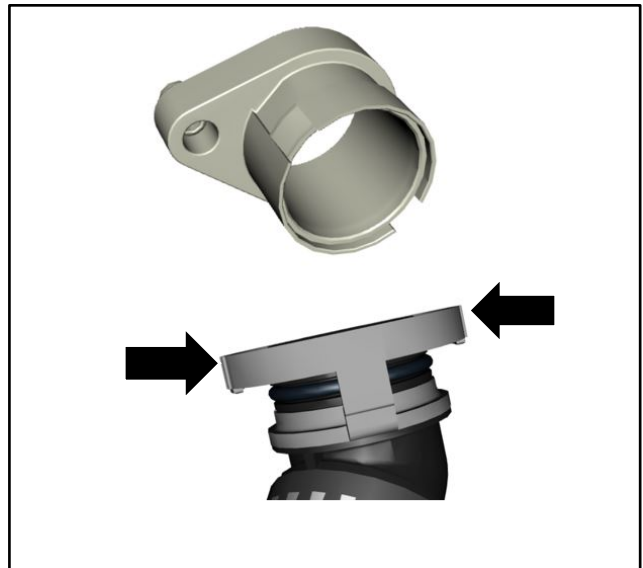

Figure 5

7. Apply LOCTITE 480 to the adaptor in the positions shown (refer to Figure 6).

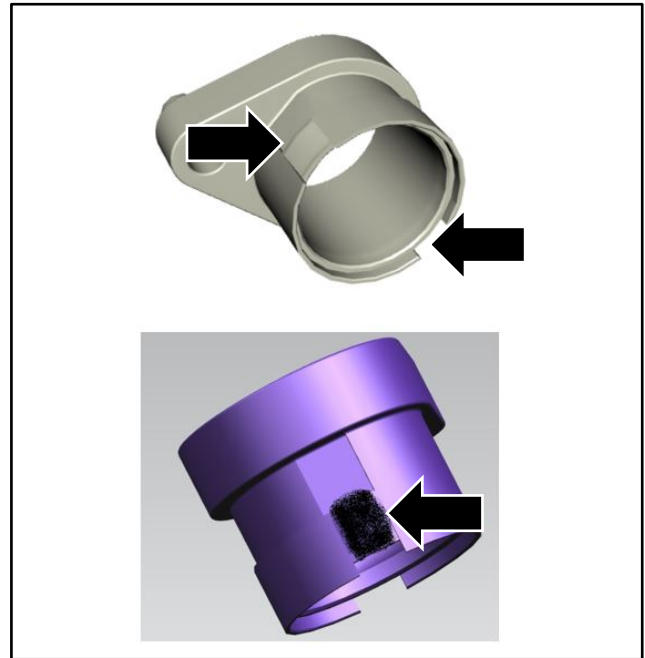

Figure 6

8. Apply LOCTITE 480 to the hose clamp in the positions shown (refer to Figure 7).

Note: Make sure the adhesive does not contact the O-ring. If glue contacts the O-ring the O-ring must be replaced.

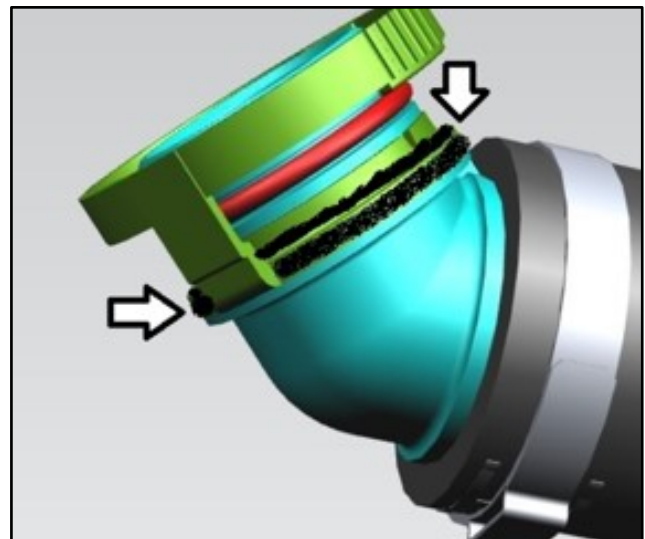

Figure 7

9. Install the adaptor to the hose (refer to Figure 8).

Note: Make sure the clip is installed correctly on both sides and the adaptor is correctly aligned. Let the adhesive cure for 30 minutes before it is installed.

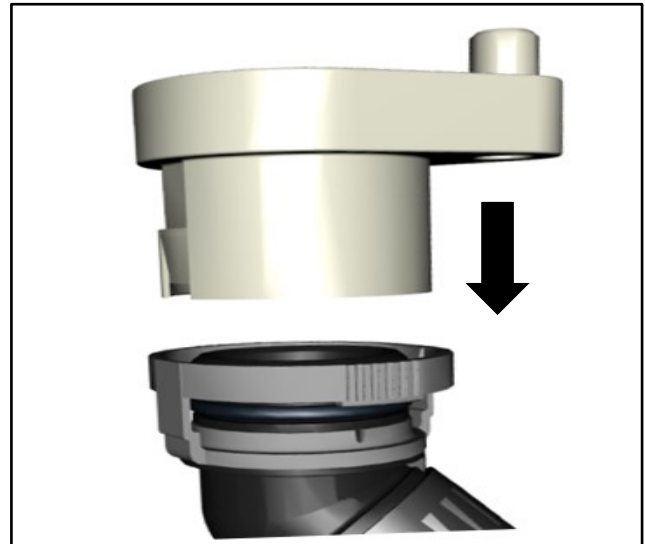

Figure 8

10. Apply black Hylomar jointing compound to the O-ring on the sound regulator (refer to Figure 9).

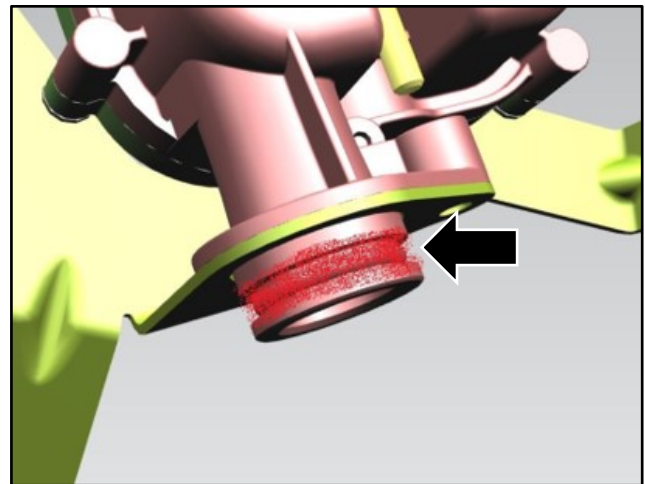

Figure 9

11. Install the adaptor and hose assembly (refer to Figure 10).

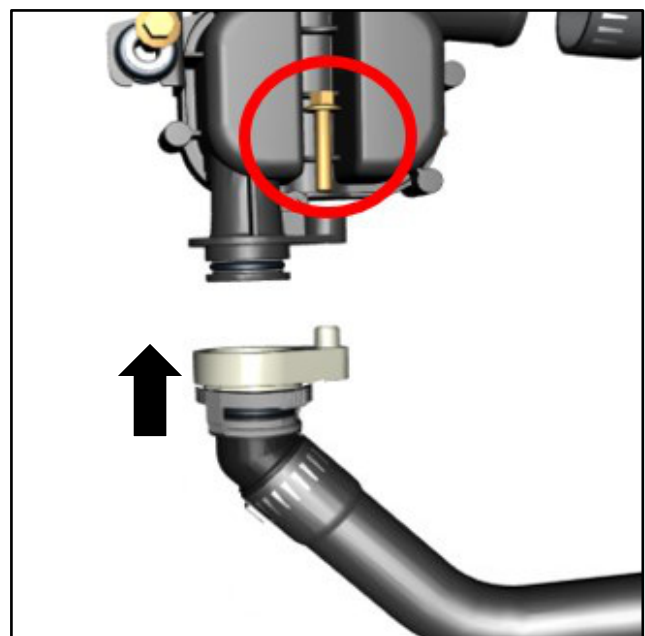

Figure 10

12. Install the bolt and torque to 10 Nm.

Note: *Let the black Hylomar cure for 30 minutes before you do a smoke test.*

13. Move the fuse boxes back into the correct positions (refer to Figure 11).

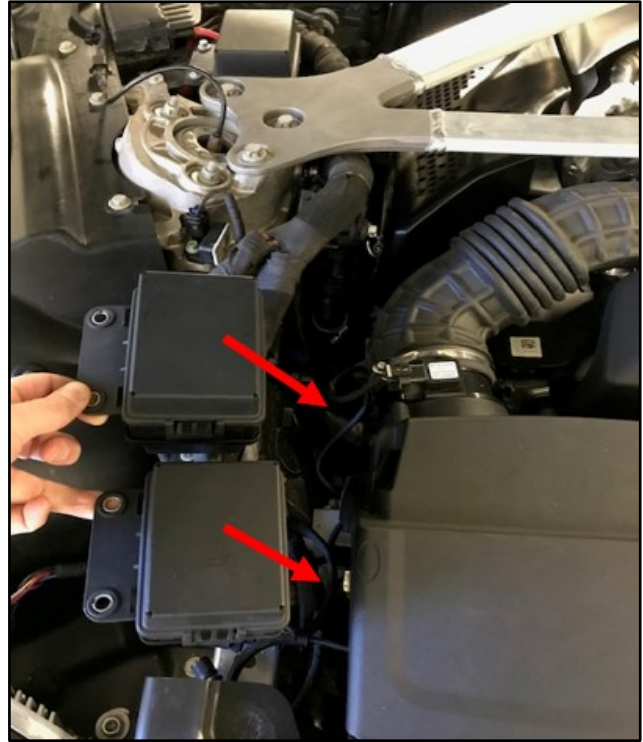

Figure 11

14. Torque the four bolts to 5Nm (refer to Figure 12).



Figure 12

15. Connect the vehicle battery (refer to Workshop Manual procedure 14.01.CA).
16. Start the vehicle and let the engine get to operation temperature.
17. Do a test drive of the vehicle.
18. Make sure that the hose has sealed correctly to the sound regulator.
19. Make sure the malfunction indication lamp (MIL) light is off.

Part Data

Description	Part Number	Quantity
Loctite 480	699269	As required
Black Hylomar	700927	As required

Warranty Data**Procedure and Labour Time**

Description	Labour Time
Remove and repair the sound regulator	0.80

Please Note:

When you have completed this Service Action, make sure that you make an entry in Section A of the Vehicle Owner's Guide to show that the procedure is completed.

If you have any questions related to this Service Action, please contact: Aston Martin Technical Services on: +44 (0) 1926 644720, email: askamtech@astonmartin.com, or contact your After Sales Manager.

The English version of this Service Action is written in Simplified Technical English to ASD-STE100™.