

QUARANTINE NOTICE

Reference number:	QN-01-1145	Issued: 23 November, 2018
Subject:	Door Clash to Bonnet	
Model(s):	Vantage 19MY	
VIN range:	Refer to the separately published list of Vehicle Identification Numbers (VINs)	
Applicable to:	All Dealers	
Distribute to:	After Sales Manager Executive Manager Service Manager Sales Manager	Warranty Staff Technician(s) Parts Staff

Note: *This repair is the same as Service Action SA-01-1145. Use this Quarantine Notice for vehicles that are not registered and have not been given to a Customer.*

Some vehicles in the affected VIN list for this Quarantine Notice may now be registered and given to a Customer. Make sure that you do a check of the Online Dealer Warranty (ODW) database to make sure that all necessary work is done to every vehicle.

Reason for this Quarantine Notice

On some Vantage 19MY vehicles it is possible that door can touch other parts of the vehicle when the door is opened. This can cause damage to the paintwork. Do the Workshop Procedure that follows to prevent this problem.

Workshop Procedure

CAUTION: BE CAREFUL WHEN YOU OPEN AND ADJUST THE DOOR. THE PAINTWORK CAN BE DAMAGED IF PARTS TOUCH.

Note: *The following clearances are applicable:*

- *The clearance (in the car's X-axis) between the door and the bonnet should be approximately 3.5mm.*
- *The door must be inboard of the front wing panel approximately 1mm.*

1. Open the side doors and check that they do not touch the parts in front of them.
 - If a door touches the bonnet, do steps 2 thru 3.
 - If a door touches the front wing panel, do steps 4 thru 5.
 - If both doors open without problem the procedure is completed.



Figure 1

Note: Do steps 2 thru 3 if a door touches the bonnet.

2. Open the bonnet and adjust the height (on both sides) with the bonnet stops and the bolts (refer to Figure 2).

CAUTION: THE BONNET CAN BE DAMAGED IF THE BONNET STOP IS OVER ADJUSTED.

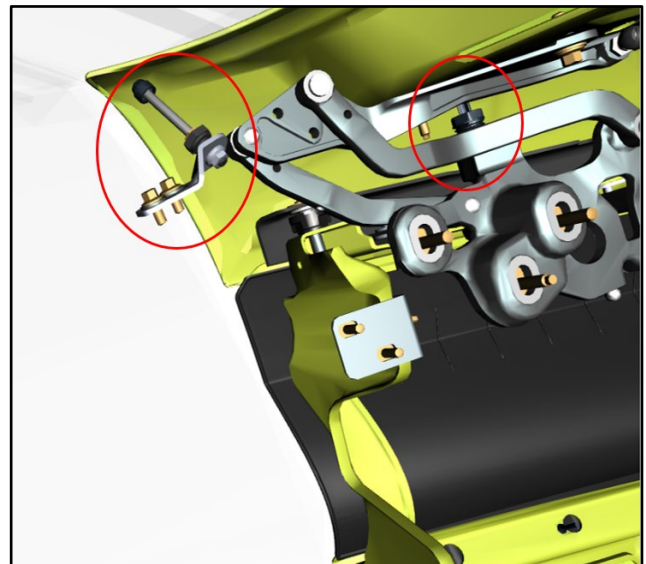

Figure 2

3. Close the bonnet and make sure it aligns with the car body 'style line' (refer to the area shown in Figure 3).
 - If a door aligns with the style line, go back to step 1.
 - If a door does not align with the style line, go back to step 2.

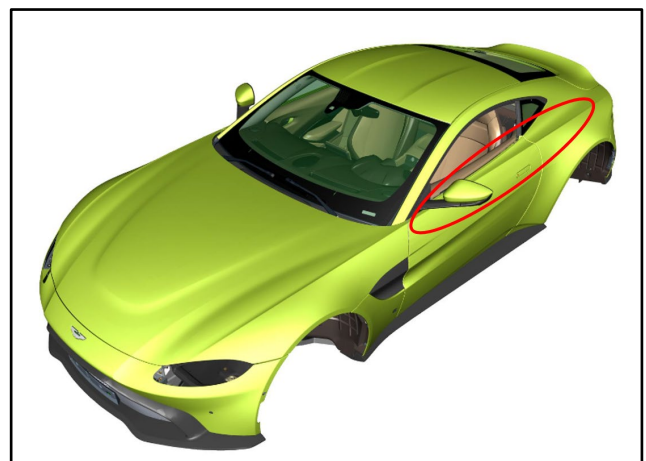

Figure 3

Note: Do steps 4 thru 5 if a door touches the front wing panel.

4. Adjust the top and bottom hinge positions to move the door in the Y-axis. (Refer to Figure 4 for the top hinge and Figure 5 for the bottom hinge.)



Figure 4



Figure 5

5. Check that the door does not touch other parts of the vehicle when it is opened.
 - If the door touches the front wing panel, go back to step 4.
 - If the door touches the side gill panel, go back to step 4 or adjust the position of the side gill panel in steps 6 thru 10.
 - In all other cases go back to step 1.

Note: Steps 6 thru 10 are an alternative method to increase the clearance between a door and the side gill panel.

- 6. Remove the rear mounting panel for the headlamp from the body.
 (For the left side panel, refer to Figure 6 and Workshop Manual Procedure 01.02.LB, steps 2 thru 6.)
 (For the right side panel, refer to Workshop Manual Procedure 01.02.KB, steps 2 thru 14.)

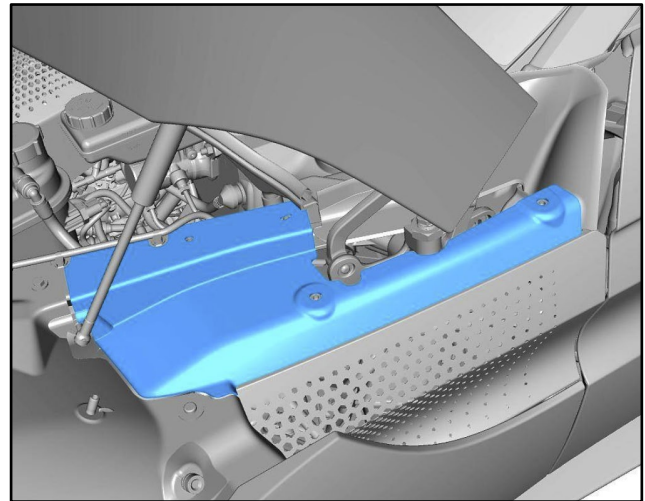

Figure 6

- 7. Loosen the two nuts that attach the side gill panel to the front wing (refer to Figure 7).

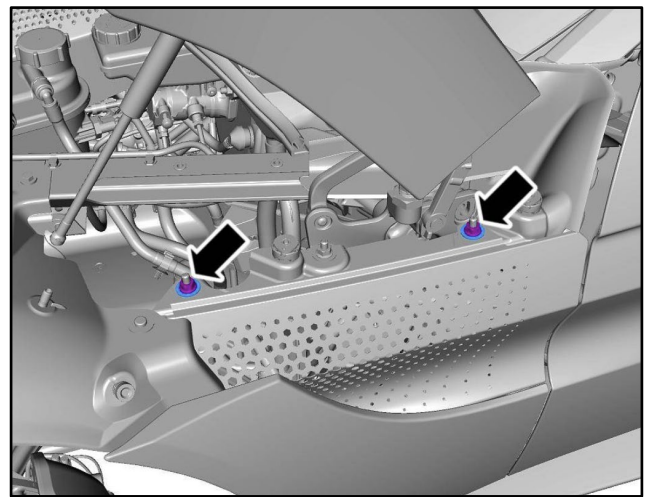

Figure 7

- 8. Adjust the position of the side gill panel and open the side door to check that the parts do not touch.
- 9. Tighten the two nuts when the side gill panel is in the correct position.
- 10. Go back to step 1.

Part Data

N/A

Warranty Data

Procedure and Labour Times

Tier A

Description	Labour Time
Check the clearances for 2 doors	0.05 hours

Tier B

Description	Labour Time
Adjust the bonnet height	0.15 hours

Tier C

Description	Labour Time
Adjust the hinges of 1 door	0.15 hours

Tier D

Description	Labour Time
Adjust the hinges of the LH and RH doors	0.30 hours

Tier E

Description	Labour Time
Adjust 1 side gill	0.15 hours

Tier F

Description	Labour Time
Adjust the LH and RH side gills	0.30 hours

Tier G

Description	Labour Time
Adjust the bonnet and the hinges of 1 door	0.30 hours

Tier H

Description	Labour Time
Adjust the bonnet and the hinges of 2 doors	0.45 hours

Tier I

Description	Labour Time
Adjust the bonnet and 1 side gill	0.30 hours

Tier J

Description	Labour Time
Adjust the bonnet and the LH and RH side gills	0.45 hours

Tier K

Description	Labour Time
Adjust 1 door and 1 side gill	0.30 hours

Tier L

Description	Labour Time
Adjust 2 doors and 1 side gill	0.45 hours

Tier M

Description	Labour Time
Adjust 1 door and 2 side gills	0.45 hours

Tier N

Description	Labour Time
Adjust 2 doors and 2 side gills	0.60 hours

Tier O

Description	Labour Time
Adjust the bonnet, 1 door and 1 side gill	0.45 hours

Tier P

Description	Labour Time
Adjust the bonnet, 2 doors and 1 side gill	0.60 hours

Tier Q

Description	Labour Time
Adjust the bonnet, 1 door and 2 side gills	0.60 hours

Tier R

Description	Labour Time
Adjust the bonnet, 2 doors and 2 side gills	0.75 hours

If you have any questions related to this Quarantine Notice, please contact: Aston Martin Technical Services on: +44 (0) 1926 644720, email: askamtech@astonmartin.com, or contact your After Sales Manager.

The English version of this Quarantine Notice is written in Simplified Technical English to ASD-STE100™.