

QUARANTINE NOTICE

Reference number:	QN-01-1132	Issued: 23 November, 2018
Subject:	Door Glass Seal Push Out	
Model(s):	Vantage 19MY	
VIN Range:	Refer to the separately published list of affected Vehicle Identification Numbers (VINs)	
Applicable to:	All Dealers	
Distribute to:	After Sales Manager Executive Manager Service Manager Sales Manager	Warranty Staff Technician(s) Parts Staff

Note: *This repair is the same as Service Action SA-01-1132. Use this Quarantine Notice for vehicles that are not registered and have not been given to a Customer.*

Some vehicles in the affected VIN list for this Quarantine Notice may now be registered and given to a Customer. Make sure that you do a check of the Online Dealer Warranty (ODW) database to make sure that all necessary work is done to every vehicle.

Reason for this Quarantine Notice

Aston Martin has identified a problem with the operation of the door glass in early Vantage 19MY vehicles. It is possible that the door glass can catch the door glass seal. This can then push the door glass seal off the door.

Do the workshop procedure that follows to correct this problem.

Workshop Procedure

This workshop procedure has the parts that follow:

- **Part A – Test the door glass operation**
- **Part B – Correctly align the door glass**

Part A – Test the door glass operation

1. Turn the vehicle ignition on.
2. Open the left side door of the vehicle.
3. Lower the door glass in the left side door.

Note: *Steps 4 & 5 that follow must be done at the same time.*

4. Use the 'one touch' function on the door window switch to move the door glass up. (Pull the door window switch up and then release it).
5. While the door glass moves up, close the door hard. (The door glass will momentarily stop as it moves up).
6. Open the door again and fully lower the door glass. It is possible that the door glass will now drop below the door glass seals and out of view.
7. Close the door hard.

8. Open the door and use the door window switch to move the door glass up.
9. If the door glass catches below the inner or outer door glass seal do Part B of this Service Bulletin.
10. If the door glass moves up correctly no further action is necessary.
11. Repeat steps 2 thru 10 for the door glass of the right side door.
12. Turn the vehicle ignition off.

Part B – Correctly align the door glass

Note: *Only do part B if the door glass of one or both doors catches below the door glass seals. The steps that follow show the left side door – the procedure is the same for the right side door.*

1. Make sure that the door glass in the applicable door is fully lowered.
2. Remove the door trim panel but do not disconnect the battery. (Refer to Workshop manual procedure: 01.05.GB - Trim Panel for the Right Side Front Door and / or 01.05.GQ - Trim Panel for the Left Side Front Door.) Do not do step 2 “Do the Battery disconnection procedure” in the Workshop manual procedure.
3. Remove the inner and outer door glass seals.
4. Identify the top two fixings that are used to adjust the door glass. (Refer to Figure 1 and Figure 2.)

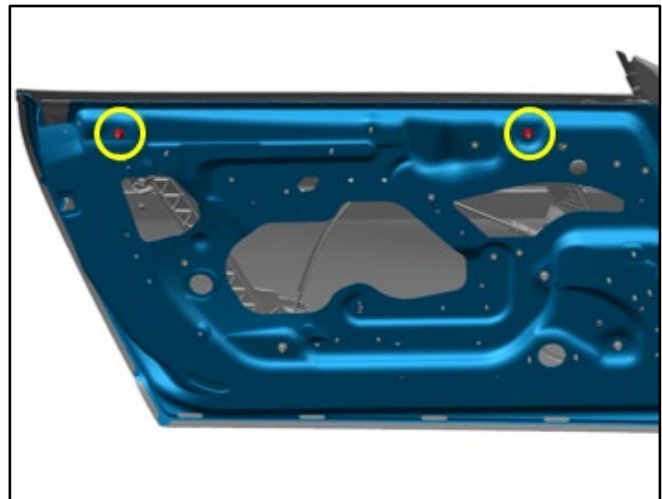

Figure 1

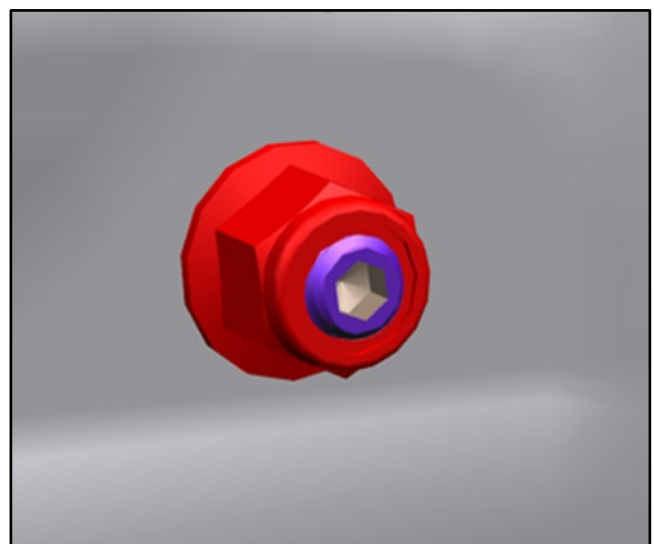

Figure 2

5. Adjust the door glass so that it is positioned in the center of the door "letterbox." (Refer to Figure 3.)

Note: An adjustment of +/- 5mm is possible with these fixings.

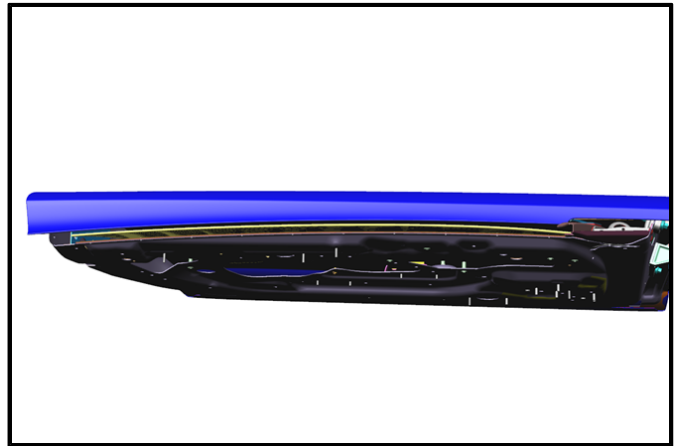

Figure 3

6. Install the inner and outer door glass seals.
7. Do steps 4 thru 8 from Part A of this Service Bulletin again.
8. If the door glass catches behind the door glass seal do steps 3 thru 7 from Part B of this Service Bulletin again.
9. When the door glass moves up correctly, torque the two fixings to 9Nm.
10. Make sure that the door glass is fully up.
11. Carefully close the door against the primary door weatherstrip.
12. Do a check to make sure that the door glass seals correctly to the primary door weatherstrip. (Refer to Figure 4 and Figure 5.)

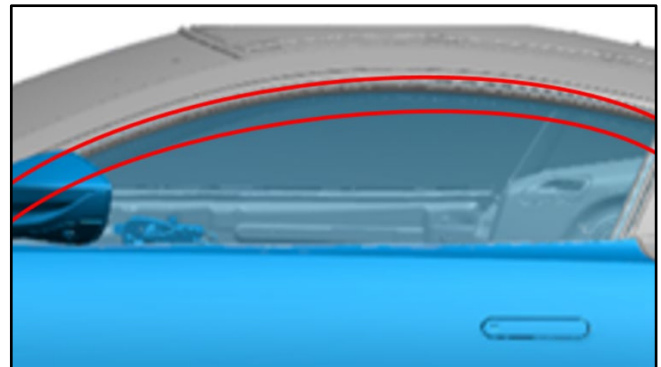

Figure 4

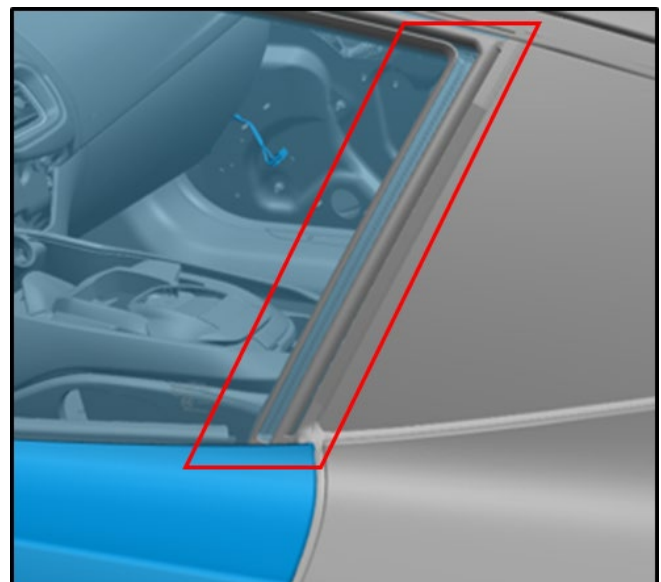

Figure 5

- 13. If the door glass seals correctly to the primary door weatherstrip go to step 18.
- 14. If the door glass does not seal correctly to the primary door weatherstrip go to step 15.
- 15. Identify the three lower regulator fixings on the inner door panel. (Refer to Figure 6 and Figure 7.)

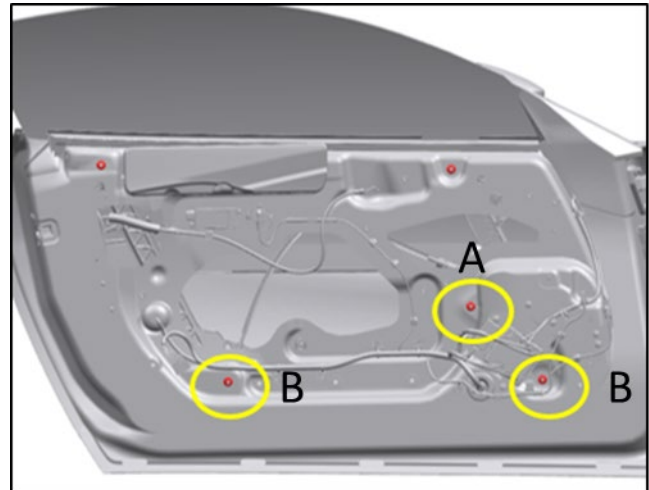

Figure 6

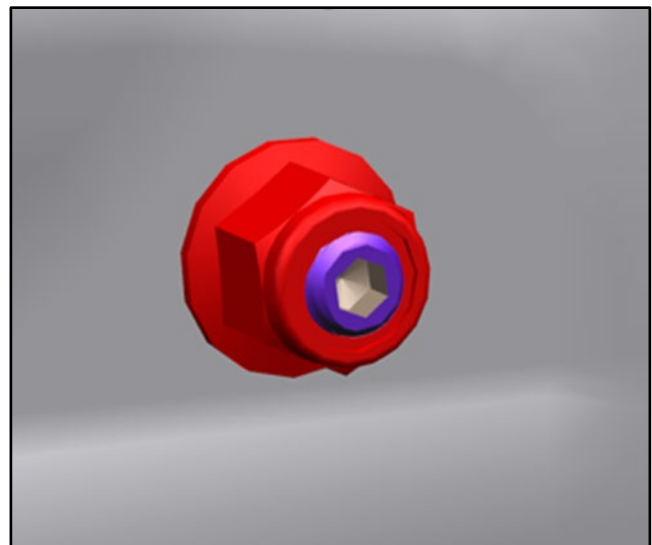

Figure 7

CAUTION: IN THE STEP THAT FOLLOWS MAKE SURE THAT FIXING “A” IS ADJUSTED BY HALF OF ANY ADJUSTMENT TO THE TWO FIXINGS “B”. (REFER TO FIGURE 6.) IF YOU DO NOT DO THIS THE REGULATOR RAIL CAN GET TWISTED.

16. Use the two lower regulator fixings to adjust the door glass in or out until it seals correctly to the primary door weatherstrip. (Refer to B in Figure 8.)

Note: An adjustment of +/- 10mm is possible with these regulator fixings.

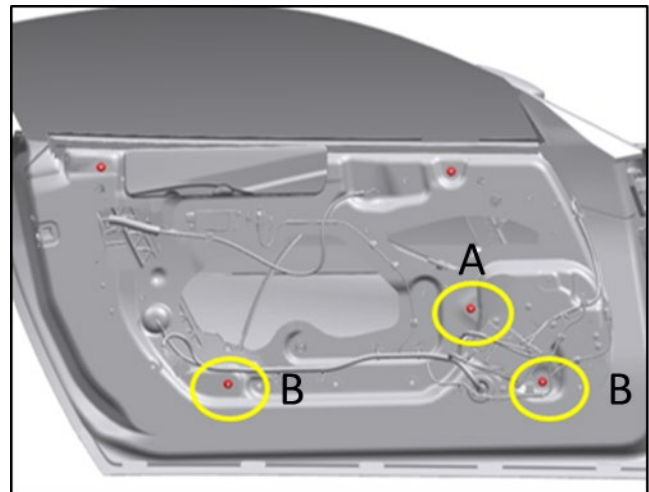

Figure 8

17. Torque the three lower regulator fixings on the inner door panel to 9Nm.
18. Carefully close the door.
19. Do a check that there is sufficient clearance between the door glass and the cantrail finisher (refer to Figure 9).

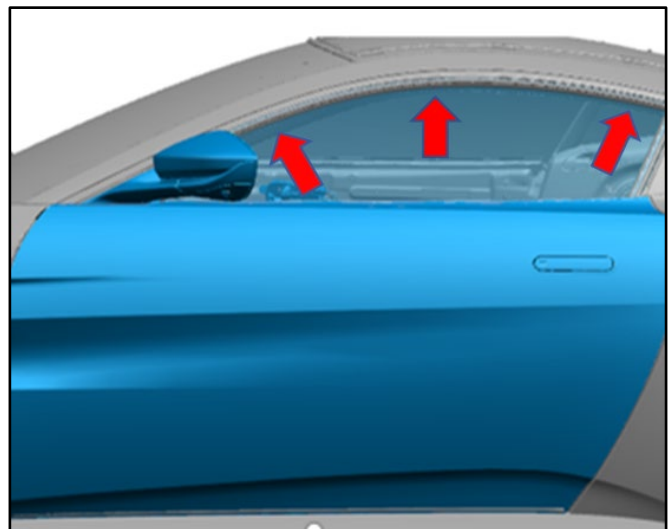

Figure 9

20. Do a check that the distance between the door glass and the rear quarter glass is correct (refer to Figure 10).

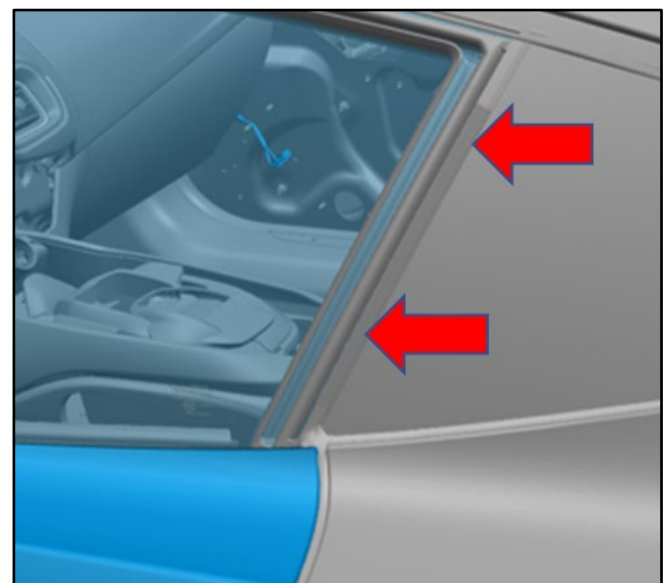

Figure 10

21. Identify the 9 dots on the front and rear of the of the door glass (refer to Figure 11 and Figure 12).

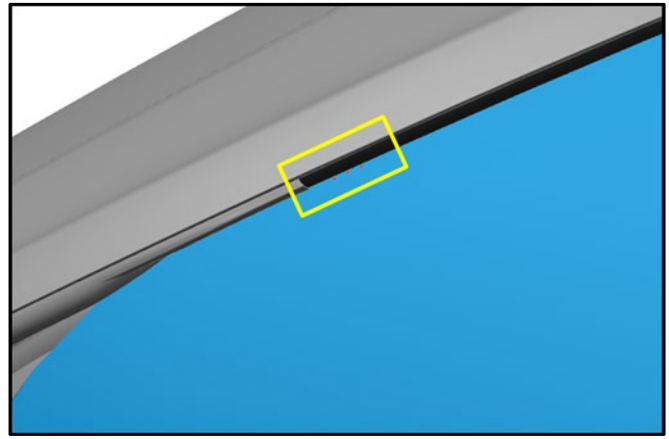

Figure 11

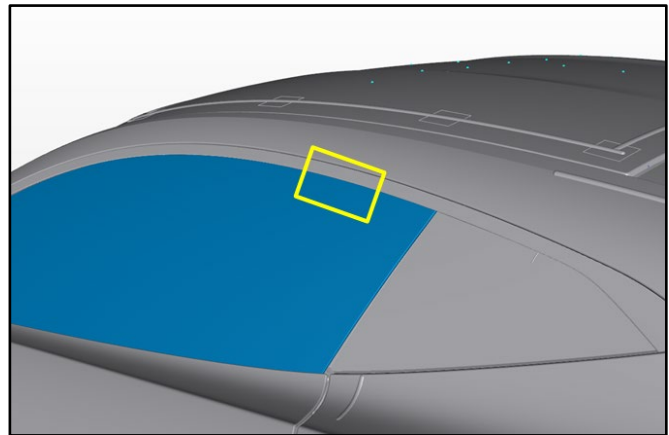

Figure 12

22. Do a check of the height of the door glass. When viewed from outside of the vehicle this should be between the middle and lower row of dots.
23. If adjustment to the height or forward to rear position of the door glass is not required, go to step 32.
24. If adjustment to the height or forward to rear position of the door glass is required, do steps 25 thru 30.
25. Lower the door glass to get access to the two bolts that hold the door glass to the door glass regulator. (Refer to Figure 13.)

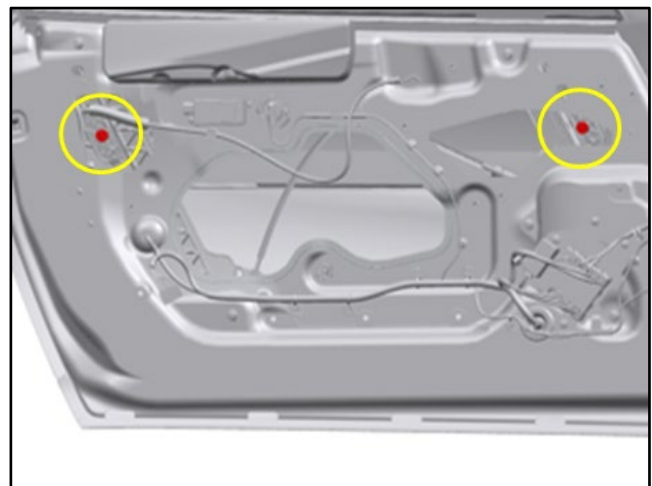

Figure 13

26. Loosen the two bolts that hold the door glass to the door glass regulator.

WARNING: PUT ON PROTECTIVE GLOVES AND EYE PROTECTION WHEN YOU HOLD THE DOOR GLASS. THE DOOR GLASS CAN BREAK AND CAUSE SERIOUS INJURY.

- 27. Adjust the door glass as necessary.
- 28. Tighten the two bolts with your hand.
- 29. Make sure the door glass is fully raised.
- 30. Repeat steps 18 thru 29 until the door glass is correctly aligned.
- 31. Torque the two bolts that hold the door glass to the door glass regulator to 5.5Nm.
- 32. Install the door trim panel. (Refer to Workshop Manual Procedure: 01.05.GQ - Trim Panel for the Left Side Front Door and / or 01.05.GB - Trim Panel for the Right Side Front Door).

Part Data

Not applicable.

Warranty Data

Procedure and Labour Time

Tier A

Description	Inspection only	Inspection and repair
Test the left-side door glass operation and, if necessary, align the door glass	0.2 hours	1.65

Tier B

Description	Inspection only	Inspection and repair
Test the right-side door glass operation and, if necessary, align the door glass	0.2 hours	1.65

Tier C

Description	Inspection only	Inspection and repair
Test the door glass operation on both left and right sides. If necessary, align the door glass	0.2 hours	3.30

If you have any questions related to this Quarantine Notice, please contact: Aston Martin Technical Services on: +44 (0) 1926 644720, email: askamtech@astonmartin.com, Or contact your After Sales Manager.

The English version of this Quarantine Notice is written in Simplified Technical English to ASD-STE100™.