

UNDERSTANDING TRAILER AIR SUSPENSIONS



H HENDRICKSON
The World Rides On Us®

Trailer Commercial Vehicle Systems



A true innovator in the industry, Hendrickson is always on the brink of new and exciting products to adapt to an ever-changing market. With goals of reliability, quality and durability, Hendrickson has proven to be the favored choice in the trailer air suspension market.

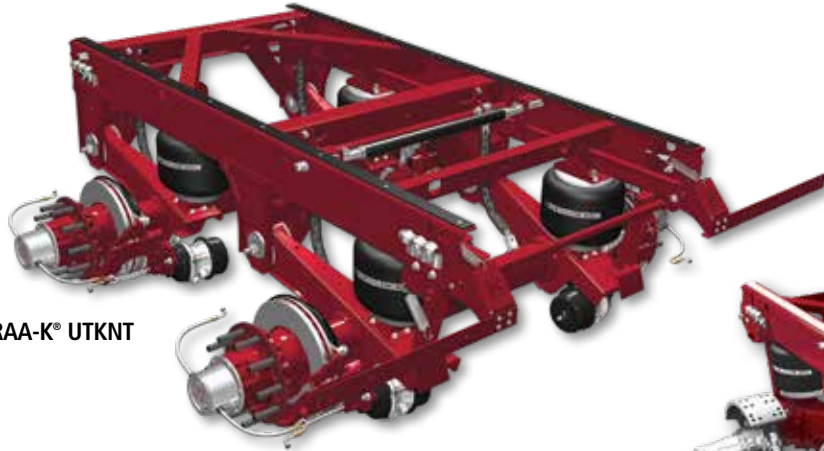

ULTRAA-K® UTKNT



VANTRAA® HKANT

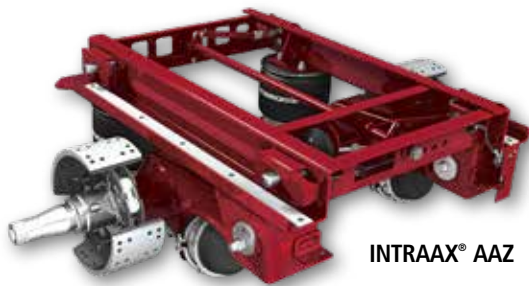

INTRAAAX® AAZ



HT™ SERIES HT230T



INTRAAAX® AAL



INTRAAAX® AANT



INTRAAAX® AAT RCA



CONNEX™-ST

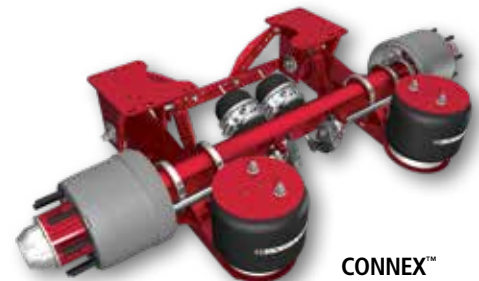

CONNEX™

866-RIDEAIR (743-3247)
www.hendrickson-intl.com

Table of Contents

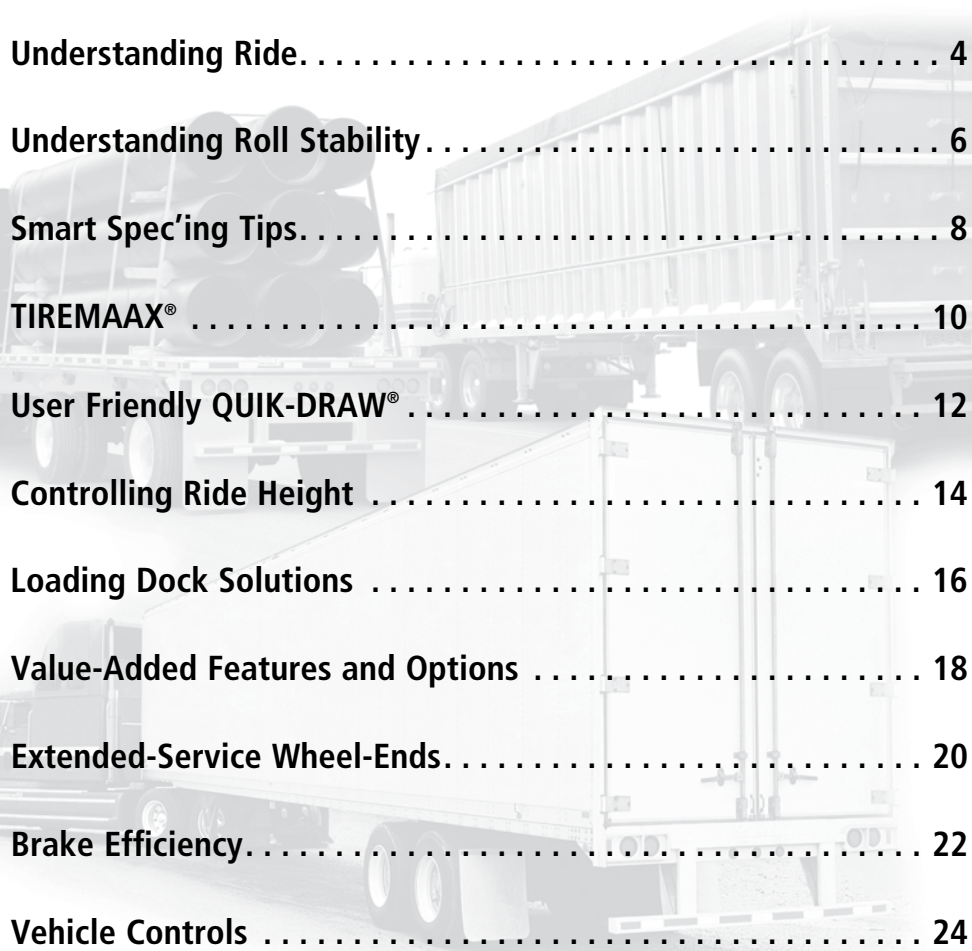

Overview Air Suspensions.....	2
Understanding Ride.....	4
Understanding Roll Stability.....	6
Smart Spec'ing Tips.....	8
TIREMAAX®.....	10
User Friendly QUIK-DRAW®.....	12
Controlling Ride Height.....	14
Loading Dock Solutions.....	16
Value-Added Features and Options.....	18
Extended-Service Wheel-Ends.....	20
Brake Efficiency.....	22
Vehicle Controls.....	24
Aftermarket.....	26
Trailer Suspensions.....	28
Standard Terminology.....	34
Applications.....	36

OVERVIEW

Air Suspensions

The popularity of air suspensions has grown in nearly all segments of the trailer industry. In 1996, air suspension acceptance accounted for 36 percent of the industry. Today air suspension usage averages about 75 percent. Truckers operating vocational trailers realized the advantages of air suspensions early. As a result, the migration to air suspensions leveled off in applications that show high percentages of acceptance such as in flatbeds and drop decks. Air suspensions continue to gain popularity for tankers and have become the suspension of choice for aluminum and combo flatbeds. Many benefits drive the steady movement to air suspensions. Fleet managers experience reduced maintenance costs and a higher resale value on their equipment by specifying air suspensions. This higher resale stems from reduced shock and vibration transmitted to the trailer from the wheels and road. In simple terms, there is less "wear and tear" on the equipment. Fleets can also experience enhanced tire life and improved fuel economy.



Shippers look for better cargo protection. Drivers like the flexibility of air suspensions, which allows them to haul a wide variety of freight while maintaining a smooth ride. Unlike a steel spring, the air spring's stiffness adjusts to the amount of weight carried by the trailer.



Drivers continue to insist on a better ride. In today's business climate, recruiting and retaining good drivers holds more importance than ever and driver satisfaction remains a key to success.

As technology advances, air suspensions become lighter and more price competitive. In addition, air suspensions increase the resale or trade-in value of a trailer. As the benefits of technological advances add up, more and more fleets and owner operators continue to make air suspensions standard.

Steadily gaining in market share, air suspensions spawned an emerging advance in the form of system integration. In 1995, Hendrickson introduced INTRAAX®, the industry's first integrated trailer air suspension, axle and brake system.



INTRAAX® AAT

AIR SUSPENSIONS



Compared to most other suspension products that require assembly of ordinary components, INTRAAX® integrated suspension systems are truly optimized designs, with each element tuned to work as part of a harmonious system. Benefits include higher standards of ride control, braking performance and overall product durability. In addition to unmatched performance and minimal maintenance, INTRAAX offers remarkable weight savings that translates into increased payloads for fleets. In 1998, Hendrickson introduced VANTRAAX®, a tandem air slider system designed for dry vans and reefer trailers. The popularity of integrated systems has grown over the last 18 years and has proven popular with both OEMs and fleets.

Haulers' jobs are much easier thanks to the extended warranty coverage provided by Hendrickson. Fleets benefit from the dramatic weight savings and durability inherent in the design of our integrated systems.



INTRAAX® AANT

Hendrickson's trailer suspensions are the finest integrated air suspension systems available today. INTRAAX and VANTRAAX deliver an extremely smooth ride whether the trailer is loaded or unloaded. This softer ride helps to reduce driver fatigue and minimizes road vibration to help diminish damage to cargo and wear and tear on the trailer chassis. Operators maximize load equalization across axles regardless of axle spacing and cargo type. Hendrickson trailer suspensions come standard with a variety of time and money saving equipment. Features such as QUIK-DRAW® for easy pin pulling on slider boxes, Cam Tube System™ and QUIK-ALIGN® for easy axle alignment are all standard on Hendrickson suspension systems. Hendrickson suspensions also have an array of value-added options to help fleets customize equipment to meet specific needs.

Value-Added Features and Options



QUIK-DRAW®



SURELOK®

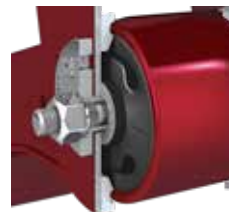

QUIK-ALIGN®



UBL™ UNDER BEAM LIFT™



ZMD®

Understanding Air Suspensions addresses in detail the advantages of riding on Hendrickson air suspensions. We believe fleet managers and owner operators will quickly see how choosing a Hendrickson system provides an edge in today's competitive market.

UNDERSTANDING Ride

Some significant benefits associated with air suspensions include maintaining consistent ride quality, enhancing driver comfort and providing cargo protection over a broad range of payloads.



How is ride quality measured?

The industry measures ride quality by the degree of isolation the suspension provides the vehicle from road inputs

without compromising vehicle control. How well a suspension isolates or protects a trailer is reflected in the extent of road forces and vibration reaching the vehicle and its cargo when in service. Minimizing these forces and vibrations results in less cargo damage and lower trailer maintenance costs.

What factors control ride quality?

Major influences on trailer cargo protection include the suspension's natural frequency and travel. In general, suspensions with lower natural frequencies reduce the

forces transmitted to the trailer and improve ride quality. The travel of the suspension is closely tied to the natural frequency. As the natural frequency drops, the amount of suspension jounce or up-travel must be increased in order to maintain acceptable ride quality.

Natural frequency comprises the spring rate of the suspension and the amount of weight the suspension is supporting. The spring rate of the suspension is a measure of the suspension's vertical stiffness or how much the suspension deflects under a load. For a given payload, the natural frequency of a suspension will be increased if the spring rate or stiffness of the suspension is increased, and it will be decreased if the suspension spring rate is decreased.

Why do air suspensions work better?

Air suspensions are capable of achieving very low natural frequencies and providing very high levels of trailer and cargo protection. Suspension geometry and air spring design work together to produce natural frequencies below 1.5 Hz. Recalling that lower natural frequencies create lower cargo forces, typical mechanical suspensions have natural frequencies that range from 2 to 5 Hz, depending on payload.

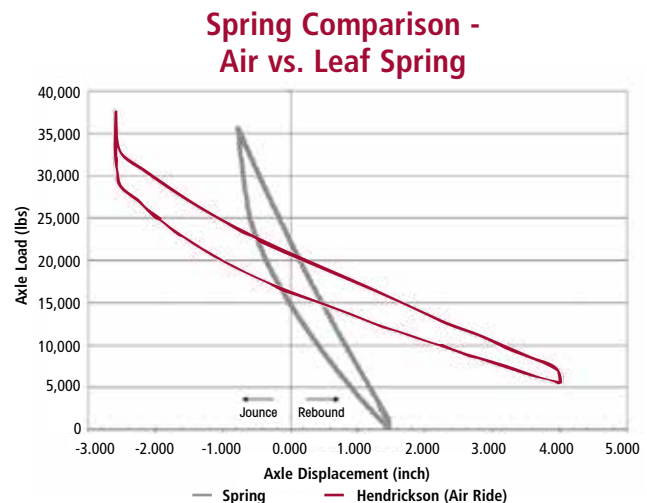
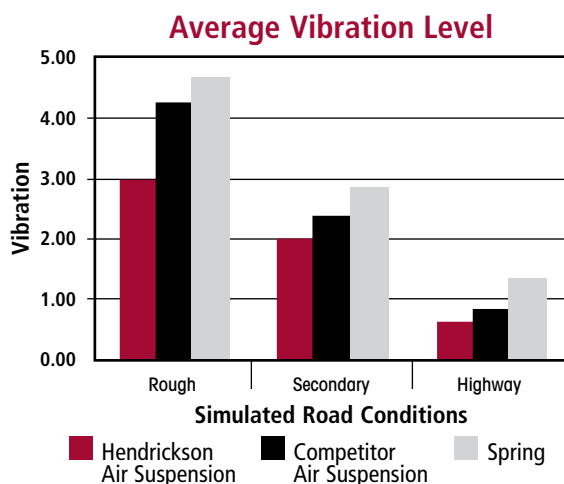

For all road conditions, Hendrickson air suspensions deliver superior ride quality and cargo protection.

AIR SUSPENSIONS



An air suspension changes its spring rate to match the load it supports; a spring ride does not. Thus, air suspensions deliver benefits that a spring suspension cannot offer:

First, when the spring rate changes with the load, the natural frequency of the suspension remains at a constant, low level resulting in consistent cargo protection regardless of payload.

Second, the suspension static height, therefore the trailer static height, stays constant, which prevents the loss of suspension jounce (up travel) when loading the trailer. This is important when trying to maintain required isolation levels for suspensions with low natural frequencies.

Not all air suspensions are equal

Just because a trailer has an air suspension doesn't mean it delivers a good ride. The ride quality and vehicle control a suspension provides is a result of the design of the suspension as an integrated system. The suspension system must work together with the trailer in its application to give optimum system performance.

A Hendrickson air suspension is designed to achieve optimum suspension system performance. Hendrickson does this by designing a complete series of integrated suspension systems to meet virtually any trailer application.

THE HENDRICKSON ADVANTAGE

Integrated suspension systems

Some air suspension designs are simply a compromise of off-the-shelf components combined into workable suspension geometry. At Hendrickson, the core of our suspension system performance is in the details of the development of an integrated suspension system. Each suspension system is designed to provide the optimum combination of ride quality and vehicle control.

Suspension geometry, travel, load capacity, suspension spring rate and damping levels are all interdependent characteristics that the suspension engineer manages when developing an integrated suspension design. No single element alone can determine ride quality. Rather, all of these factors must be carefully considered when designing a suspension with superb ride characteristics.

Hendrickson controls the design details of the air spring and shock absorber and their positions on the suspension. Air springs are specified for load capacity and to provide a spring rate and length matched to the suspension travel requirements. Hendrickson shock absorbers meet specific targets for damping levels based on suspension geometry, application and actual fleet experience. Designing the details into our suspension systems results in a superlative combination of ride quality and vehicle control under varying conditions using premium, serviceable components and systems.

Hendrickson Trailer Commercial Vehicle Systems designs and manufactures truly integrated suspension systems that are optimized for all trailer needs.

UNDERSTANDING Roll Stability

A vehicle's ability to resist rollover determines its roll stability. A vehicle loses its ability to resist rollover when the tires on one side lift off the ground. Many elements of a vehicle's design play a factor in determining its roll stability.

Roll stability for a trailer can largely be determined by the height of the center of mass of the trailer and the axle track. These factors can have the greatest impact on the roll stability of the trailer. For example, changing the trailer's axle track from 71.5 to 77.5 inches can improve its roll stability by eight percent. Reducing the height of the trailer's center

of mass from 70 to 65 inches can also improve roll stability by eight percent.

Chassis flexibility, the suspension, tire and axle deflections are all factors that need to be considered when determining a trailer's roll stability. Hendrickson trailer suspensions provide the cargo protection of an air suspension along with roll stability performance equal to a steel leaf-spring suspension.

THE HENDRICKSON ADVANTAGE

Hendrickson air suspensions provide a soft ride for driver comfort as well as cargo and equipment protection. At the same time, a Hendrickson air suspension provides roll stability equivalent to a leaf-spring suspension. This is evident in the chart below, which shows that while air and leaf-spring suspensions exhibit different degrees of roll, both suspensions reach tire lift-off at approximately the same cornering speed.

Since both suspensions reach roll stability limit at approximately the same cornering speed, both suspensions are considered to provide the same roll stability performance.

However, suspension vertical stiffness can be quite different between air and leaf-spring suspensions.

The vertical stiffness of a leaf-spring suspension can be four to five times stiffer than a Hendrickson air suspension. While a soft ride seems to be in conflict with roll stability, in reality it is not. The answer lies in the fundamental difference between the suspension types. Since air suspensions provide a considerably softer ride

than leaf-spring suspensions, they must rely on other means to achieve roll stiffness. This other means, commonly referred to as "auxiliary roll stiffness," comes from the axle on Hendrickson trailer air suspensions.

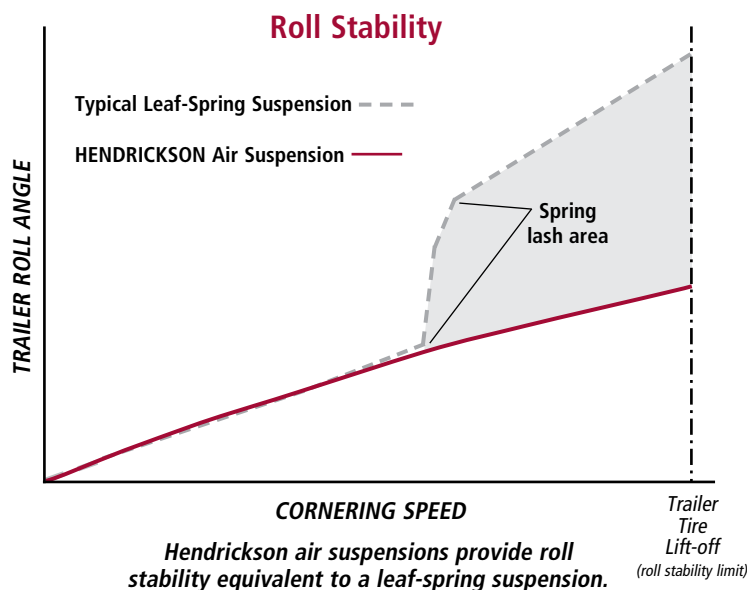

AIR SUSPENSIONS

Hendrickson air suspensions resist trailer roll by utilizing the axle in a manner similar to a torsion bar. The axle tube provides the necessary trailer roll resistance that is equal to or greater than what can be provided by a leaf-spring suspension. At the same time, the air suspension eliminates the spring lash angle of a mechanical suspension resulting in a lower roll angle for air suspensions. This allows Hendrickson air suspensions to have roll stability characteristics similar to spring, while providing a ride that is significantly superior to a leaf-spring suspension.

What this brings to fleets and owner operators is the ideal combination of ride softness and roll stability — in other words, the ultimate in cargo protection and comfort.

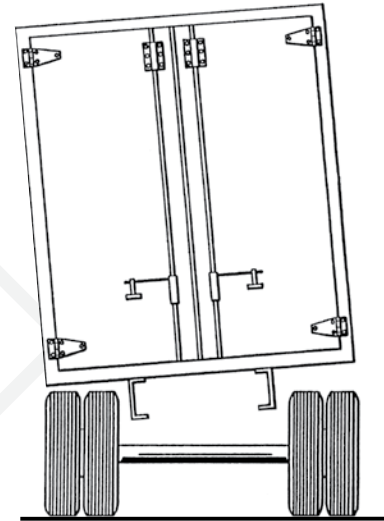

Low-speed cornering event

- Trailer roll resisted by suspension

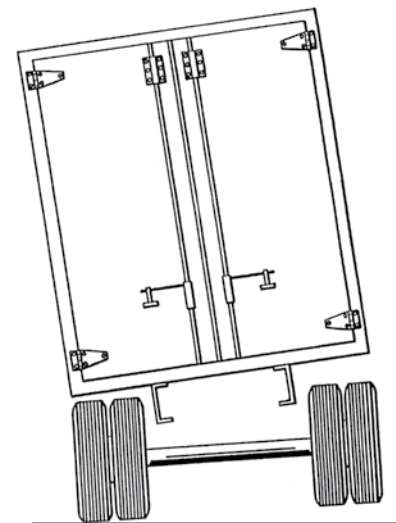

High-speed cornering event

- Tire lift-off
- Approaching roll stability limit



SMART Spec'ing Tips

The decisions fleets and owner operators make about the equipment they run can have a dramatic impact on operations and profitability. Recognizing the importance of wise spec'ing choices, Hendrickson lists eight tips outlining how choosing a Hendrickson trailer air suspension can make a difference.

TIP #1

Look for a suspension brand with a good reputation. A proven track record is a good indication of your ownership experience and how you will be treated after the sale. It can also help down the road when the trailer is sold.

As a market leader, Hendrickson Trailer Commercial Vehicle Systems builds its reputation on air suspension system excellence. Hendrickson's brand equity and reputation for superior engineering, service and support is strong in the market, and will retain a premium on trailer resale.

TIP #2

Look for fully integrated systems (suspension, axle and brakes). With a truly integrated system, each element is designed and tuned to work together for optimum performance. Not only does this ensure the system will perform well, but it keeps weight down and offers the convenience of a single source for warranty and technical support.

Hendrickson offers the finest integrated air suspension systems available. In 1995, Hendrickson introduced INTRAAX®, the first integrated trailer air suspension, axle and brake system. Two years later, Hendrickson introduced VANTRAAX®, a tandem air slider system designed for dry vans and reefer trailers. Hendrickson continued to integrate more components into a single suspension system with the introduction of proprietary wheel-end packages. Launching a new era of virtually maintenance free suspension systems, Hendrickson's leading warranties protect everything from the integrated suspension, axles, air springs and shock absorbers to the brakes and wheel-ends.

TIP #3

Select a product with a good performance record in the field. A good warranty and solid support are important, but experiencing little or no downtime is better. Hendrickson suspension components are designed and tested for strength and durability over the lifespan of your equipment.

When service is required, Hendrickson offers excellent technical support and the most extensive warranties in the industry.

TIP #4

Look for systems providing minimal maintenance requirements. This includes a minimum number of fasteners, bushings and other wear items. Check for fastener re-torque requirements — again, the fewer the better.

Hendrickson suspensions are designed with very few wear items to minimize maintenance. In many applications, our TRI-FUNCTIONAL® Bushings last the life of the trailer. Unlike most other suspension brands, our current designs have no re-torque requirements. With Hendrickson suspensions, routine maintenance is generally as simple as a visual inspection.



TFII

TFIII

TRI-FUNCTIONAL® Bushings

AIR SUSPENSIONS



TIP #5

As for those items that are most likely to need replacing over time, such as air springs and shock absorbers, check to see how quickly and easily they can be replaced. Check for easy access to those parts in the aftermarket.

Maintenance on Hendrickson suspensions is very easy, thanks to thoughtful designs. Hendrickson parts are very accessible in the industry. This is due to the vast number of distributors that stock Hendrickson Genuine Parts and the large number of suspension units we have operating around the world.



TIP #7

Always consider the application requirements when spec'ing a suspension system. Capacity and duty cycles will help determine what suspension system rating will be needed. Over or under-spec'ing can cause problems: over-spec'ing a suspension adds unnecessary cost and weight, while under-spec'ing a system can lead to premature wear and suspension damage as well as ride quality and control problems. Know how the vehicle will be used. Lots of empty backhauls could make a lift kit, such as Hendrickson's UBL™ UNDER BEAM LIFT™ a viable option to reduce tire wear.

Hendrickson's INTRAAX® and VANTRAAX® suspension families can support a variety of application requirements, from standard hauling to extreme heavy-duty, from tankers to flatbeds, from dumps to vans.

TIP #6

Be sure to consider suspension system weight. This is especially important if trailers tend to gross out in weight rather than max out in cube space. Even if you are not spec'ing for heavy loads, a lightweight suspension can help improve fuel efficiency and improve flexibility in accepting backhaul loads.

Hendrickson delivers some of the lightest air suspensions in the industry. A lower suspension system weight will help maximize payload and add to fuel efficiency.

TIP #8

Look for features and options that make a system easier and more efficient to use. Slider pin-pull assist mechanisms, pivot connections that facilitate axle realignment and dock walk prevention devices are popular. They can save fleets headaches by improving operating efficiency.

Hendrickson integrated suspension systems feature value-added items such as QUIK-DRAW®, QUIK-ALIGN® and SURELOK®. These features help improve vehicle efficiency and add to driver satisfaction.



VANTRAAX® HKANT



INTRAAX® AANLS

UNDERSTANDING

UNDERSTANDING TIREMAAX®

The majority of truckers agree that tires represent the most important maintenance item on a trailer. The simple activities of maintaining proper tire pressure and checking for irregular wear can extend tire life substantially, reduce maintenance and save thousands of dollars annually.

Tires remain the number one reason for trailer breakdowns weighing in at 48 percent of 63,789 road calls, according to a recently published survey. The Technology and Maintenance Council (TMC) reports a study of tire pressures on 35,128 vehicles, which revealed that 56 percent of vehicles are more than 5 psi off target pressure and more than 7 percent are under-inflated by 20 psi or more.

In terms of fuel economy, an industry rule of thumb attributes a 1 percent reduction in miles per gallon for every 10 psi under the specified inflation pressure. Truckers know the pitfalls of improper tire inflation: reduction in tread and casing life, as well as increases in rolling resistance, which burns more fuel and creates a poor ride.



Even properly maintained tires are subject to air loss through punctures, road hazards and changes in ambient temperature. Irregular tread wear can develop when the pressure of joined dual tires differs by as little as 5 psi.

Without enough air, tires flex too much causing excessive heat, rolling resistance and corresponding drop in fuel economy. Tires wear unevenly and become more prone to damage from road hazards and curbing.

Tire disintegration, exemplified by zipper rips and the dreaded "alligators" (black shards of rubber seen along highways), presents more extreme examples of problems caused by under inflation.

Fleet managers and owner operators continue to struggle with finding ways to maintain proper tire inflation, when simply putting a little air in the right place at the right time can save a lot of effort and expense on trailer operations.

THE HENDRICKSON ADVANTAGE

Hendrickson brings a breath of fresh air to tire pressure pitfalls with its TIREMAAX® tire inflation systems. Two versions of the popular system are available. TIREMAAX CP features a simple mechanical design, while TIREMAAX PRO is an advanced automatic tire pressure control system that actively controls tire pressures by inflating or relieving air from tires when necessary. TIREMAAX uses the trailer air supply to maintain tire pressures to a preset level. This can help minimize costly, excessive tire wear and improve productivity and fuel mileage. The system detects changes in pressure and responds by directing air to an under-inflated tire. An indicator light alerts the driver to system status.



AIR SUSPENSIONS



With the TIREMAAX® CP system, customers enjoy the simplicity of a continuous pressure system. With robust components and no electronics, transducers or pressure switches, TIREMAAX CP is easy to maintain.

The revolutionary TIREMAAX PRO shares all the features and benefits of the CP system; whereas TIREMAAX CP can only inflate a tire that drops below the recommended psi, TIREMAAX PRO addresses the issue of over-inflation. By responding to changes in ambient temperature, TIREMAAX PRO has the capability to relieve air from a tire that is over-inflated. PRO also constantly pressurizes and equalizes trailer tires, reducing scrubbing between duals and improving tire life.

With both TIREMAAX systems, air travels from the supply tank through air lines inside the axle to the wheel-ends, which eliminates the need to pressurize the axle tube and neutralizes a source for wheel-end contamination. A rotary union that is integrated into the hubcap allows air to flow from a non-rotating axle spindle to the rotating hubcap fitting. Durable tire hoses connect the hubcap to the valve stems.

All TIREMAAX systems are available with a signal light, designed for installation in view of the driver. It alerts the operator to system status and maintenance activity. Check valves prevent tire pressure loss back through the system.

Manual fill and pressure checks may be accomplished at the hose ends. TIREMAAX connects all tires to the trailer air supply and may be combined with any of an extensive array of wheel-end configurations and spindles available on INTRAAX®, VANTRAAX® and ULTRAA-K® integrated suspension systems and TRLAXLE® non-integrated axles. Hendrickson TIREMAAX systems provide a cost-effective approach to eliminate tire pressure problems.

**For additional information:
TIREMAAX PRO
Tire Inflation System —
L1199**

**TIREMAAX
Tire Inflation System —
L1017**

**TIREMAAX Tire
Inflation System
Installation, Service
and Troubleshooting
Procedures — T51002**



*Download current literature
at www.hendrickson-intl.com*

**TIREMAAX® PRO
Controller**



**TIREMAAX® CP
Controller**



TIREMAAX® PRO



USER FRIENDLY QUIK-DRAW®

Drivers often struggle to reposition a slider under a trailer. The net result is often unhappy, unproductive and sometimes injured drivers. The most common reason for this situation is difficulty in retracting the lock pins that hold the slider in a given position on the trailer. Even if the mechanical linkage used to retract the lock pins functions properly, the pins can become jammed or bound against the positioning holes in the trailer's body rails. The forces causing this binding can be due to a number of reasons such as the trailer sitting on uneven ground or the parking brakes being set while the lock pins are pushed tightly against the front or rear of the body rail holes.

To aggravate these situations still further, sometimes the body rail holes wear grooves into the unhardened lock pins creating a mechanical interlock between the lock pins and the body rails.

When this binding occurs, the driver may not be able to exert enough force against the pull handle of the lock pin retraction mechanism to disengage the pins. The driver then goes back to the cab, releases the parking brakes and

moves the rig slightly in an attempt to center the pins in the body rail holes. This action may have to be repeated until a position is found that allows the pins to be pulled. Particularly frustrating with a conventional mechanism, a single jammed pin can prevent the handle from being pulled even if the other three pins are free to move.

Sometimes, in an effort to bypass this time-consuming and inconvenient process, the driver will exert extra effort against the pull handle in an attempt to force the jammed pins free, risking back and shoulder injuries. These injuries can result in lost time and worker compensation claims.

Occasionally after repositioning a slider, a driver forgets to re-engage the slider's lock pins. When this happens, the slider may violently thrust against the slider restraint bar at the first braking. This can result in a damaged slider, trailer or payload and possibly even the loss of the slider from beneath the trailer. These types of incidents present serious safety concerns as well as impediments to driver productivity and satisfaction.

THE HENDRICKSON ADVANTAGE



Hendrickson addresses these concerns by tapping trailer air power to make true fingertip slider pin release a reality with QUIK-DRAW®. With versions for VANTRAAX® van and reefer slider systems and INTRAAX®-SP platform sliders, QUIK-DRAW triggers with a simple pull of a knob.

QUIK-DRAW relieves drivers from the tugging, jerking and hammering associated with releasing locked or jammed slider pins. With pins released in seconds, slider repositioning

becomes faster and more efficient — getting rigs back on the road sooner.

Standard on all VANTRAAX air slider systems, the patented van-style QUIK-DRAW features actuators consisting of a fabric-reinforced rubber tube. Fittings at each end attach to the inboard ends of our slider's hardened lock pins. One actuator per axle controls the two lock pins and the conventional mechanical linkage components are completely eliminated. When the knob of the valve is pulled, these unique actuators are pressurized by the trailer's compressed air supply.

AIR SUSPENSIONS

Once pressurized, the actuators increase in diameter and shorten in length, exerting a powerful pulling force — several times greater than most conventional mechanisms — to retract the pins. If the pins are free to move, they all retract, and the slider can be repositioned. However, even if one or more pins are bound, the actuators continue to apply pressure. When the driver returns to the cab to reposition the slider, movement of the trailer above the slider will “jiggle” the jammed pins free, and the actuators will retract those pins. The slider can be repositioned without difficulty.



As an additional safety feature, QUIK-DRAW® automatically resets pins with the release of the trailer parking brakes. Hendrickson equips the valve of the VANTRAAX® version with an air-pilot reset plumbed to the parking brake circuit. If the driver forgets to reset the lock pins before driving away, simply releasing the parking brake dumps air from the QUIK-DRAW actuators, shifts the valve knob to the “pins engaged” position and allows the coil springs to reset the pins in the body rails. Even if the lock pins do not align perfectly with the body rail holes, the pressure of the QUIK-DRAW coil springs pushing the pins outward will be maintained until engagement occurs. Thus, the pins will be forced out through the next available set of body rail holes as the slider moves past.

The durability and reliability of the QUIK-DRAW system enhances its simplicity. Most moving parts of a



QUIK-DRAW allows drivers to disengage the slider's lock pins using only fingertip effort.

conventional mechanism have been eliminated in the van version. Hendrickson makes the actuators from the same sturdy material as an air spring and tucks them inside the slider frame to protect from road debris. The actuator valve meets stringent durability and environmental conditions — operating in temperatures to minus 40 degrees. The valve is mounted in a recessed manner on a bracket with a shield to protect the valve from road debris, snow and ice.



An air-activated QUIK-DRAW comes standard on INTRAAX®-SP platform slider systems featuring a proven air chamber actuator with automatic reset. The chamber fits neatly inside the slider cross member for added protection.

What this means to the fleet owner and owner operator:

- 1. Improved driver productivity** - QUIK-DRAW permits a driver to efficiently reposition a slider with a single operation — even if the lock pins jam — eliminating the need for multiple trips between the cab and trailer.
- 2. Enhanced driver satisfaction** - Drivers can easily disengage lock pins. Simply pull a valve and pins will retract - no tugging, jerking or hammering.
- 3. Automatic reset** - In the event that a driver forgets to re-engage the lock pins, QUIK-DRAW automatically resets them when the trailer brakes are released.
- 4. Reduced weight** - The QUIK-DRAW van style is the lightest in the industry compared to other lock pin release mechanisms.

For additional information: QUIK-DRAW Flyer — L628

Download current literature at www.hendrickson-intl.com

CONTROLLING Ride Height

Fleets and owner operators specify trailer air suspensions for many reasons, including smooth ride regardless of payload, minimal cargo damage, load equalization and flexibility to haul a wide variety of freight. To realize these benefits, the trailer suspension must be set at its proper ride height.



Ride height is defined as the measurement from the suspension-mounting surface (the bottom of trailer frame or slider box) to the center of the axle (figure 1). Air suspensions are designed to operate at specific ride heights. Maintaining a suspension's proper ride height is a critical element of air suspension trailer

performance. The heart and soul of any air suspension system is the height control valve (HCV). The HCV maintains the trailer at its designed ride height by automatically adding and exhausting air to the trailer's suspension to compensate for changes in the trailer's load.

Operating an air suspension at an incorrect ride height can create improper load equalization, reduce ride quality, damage cargo / vehicle and result in premature suspension and component wear. Air suspensions set too high will cause shocks and air springs to be over extended.

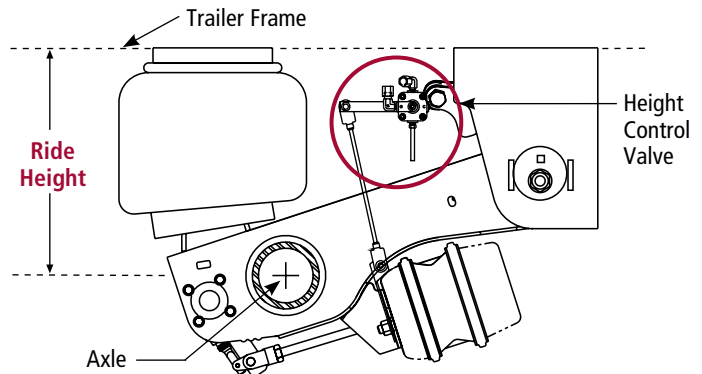

Figure 1

A suspension with a ride height set too low experiences a harsh ride due to the constant thumping against the air spring bumpers.

When height control valves and ride height settings are improperly adjusted or otherwise tampered with, premature component wear may occur. To operate properly, suspensions must ride at their specifically designed ride height. While poor ride, premature component wear or appearance might be signs of improper height settings, avoid changing ride height until a careful measurement is taken. This is the only way to be assured of proper ride height settings. The correct ride height will allow for the proper amount of suspension travel, keeping the trailer performing at peak operating efficiency.

Precise air flow regulation delivered

To deliver the ride quality and other benefits truckers expect, trailer air suspension systems require precise air flow management — a key element perfected by Hendrickson's standard height control valve (HCV) and integral HCV with automatic dump valve.

Spec'd from the OEM on new vehicles or through the aftermarket, Hendrickson's HCVs offer superb designs to keep your trailers at correct ride height.

Using an advanced Shear-Seal® design to ensure accurate air flow, Hendrickson HCVs deliver superior performance and durability. A precise, highly repeatable dead band and high air flow with a proportional response optimize ride height control to deliver superior ride quality, while prolonging air spring and shock absorber life.

AIR SUSPENSIONS



Specially designed and tested for optimum performance with Hendrickson air suspensions, our HCVs help you maintain outstanding load stability over the road. In addition, Hendrickson HCVs minimal dead band and high flow rate provide compatibility with on-board trailer weight scales.

All Hendrickson HCVs:

- **Operating pressure**
 - 130 psi (9 bar) maximum
- **Operating temperature**
 - -40°F to +150°F (-40°C to +65°C)
- **Maximum flow rate**
 - 350 L/Min (12.4 cfm)
- **Delivery ports**
 - 1/4-inch NPT fittings
 - Dual delivery ports
- **Maximum handle movement**
 - +/- 75° for fill or exhaust
- **Options**
 - Air fittings
 - Mounting brackets
- **Dead Band**
 - +/- 2°

HCV with Integral Dump

Hendrickson's HCV with integral dump features a high-flow design for rapid exhaust to save drivers time and effort as they load, unload and get back on the road.

The dump valve automatically discharges the air springs with the setting of the trailer parking brake and begins to air up with release of the brake. Integrating the dump function in the HCV eliminates components and simplifies plumbing maintenance and installation.

Exhaust Function

- **Automatic**
 - Dumps when trailer parking brake engages
- **Dump flow rate**
 - 875 L/Min (31 cfm)
- **Dump port**
 - Normally closed
- **Dumps full suspension 40 percent faster than HCV with add-on dump valve**
 - Integral = 12 seconds
 - Add-on = 20 seconds



For additional information:
Controls Parts Catalog — L1182

Download current literature at
www.hendrickson-intl.com

Loading Dock *SOLUTIONS*

During docked loading and unloading with tow motors or forklifts, three trailer reactions can occur: trailer deck height change, trailer drop and trailer walk. Trailers equipped with air suspensions in a trailing arm arrangement (figure1) can experience all three phenomena. In addition, all trailers will exhibit a drop of between 1 to 1.5 inches due to tire deflection.

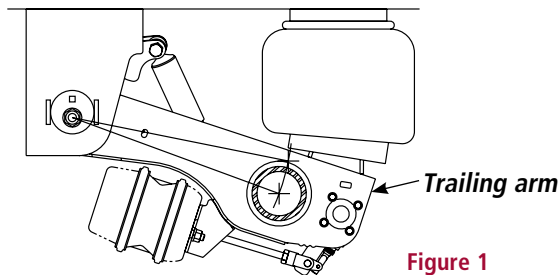

Figure 1

Trailer deck height change refers to the variation in deck height of an air suspension equipped vehicle relative to the dock after dumping the air from the system. In general, air suspension trailers equipped with a dump valve will lower 2.5 to 3.5 inches with air exhausted. The trailer comes to rest on internal air spring bumpers. Resting on the bumpers, the trailer becomes extremely stable with only significant motion resulting from tire deflection.



Trailer drop, downward trailer travel that results from a forklift entering during cargo transfer, occurs due to the inherently low spring rate that gives the suspension its soft ride. Trailer drop does not include trailer deck height changes for air suspensions. Trailer drop does not occur if the air springs have been dumped and the trailer is resting on the air spring bumpers. Trailers with mechanical spring suspensions may drop about 1.75 inches.



Trailer walk refers to horizontal trailer movement away from the dock caused by a forklift entering and exiting the trailer for cargo transfer. This horizontal movement can be caused by the suspension trailing arm's downward travel due to trailer drop. Even a mechanical suspension can exhibit walk when a heavily loaded forklift repeatedly enters the trailer with speed and stops abruptly near the front. Similarly, a loaded trailer sitting for an extended period of time can lose air pressure in its air springs, allowing the trailer deck to gradually drop. Again, this can result in forward movement that could shift the trailer away from the dock.

THE HENDRICKSON ADVANTAGE

Hendrickson offers several solutions to the trailer industry's loading dock concerns. Because specific applications and requirements vary from fleet to fleet, we provide a variety of solutions to match virtually every loading dock operation.

To maintain dock height, which naturally minimizes drop and walk, specify SURELOK®. Featuring sturdy mechanical support legs that automatically rotate and lock in place over suspension trailing arms when the trailer brakes engage, SURELOK minimizes trailer drop and walk. When using SURELOK, trailer drop is

AIR SUSPENSIONS



generally unnoticed. Support legs automatically return to their neutral position when the parking brakes are released.

Used in conjunction with an automatic dump valve, SURELOK® holds the deck height change to about an inch while virtually eliminating drop and walk in almost all loading conditions.



SURELOK holds the trailer at dock height during loading and unloading, limiting the vertical and horizontal movements that result in trailer drop and trailer walk.

When trailer walk is a concern, but deck height is not, dump valves may be the answer.

Controlled by the driver, manual dump valves lower the trailer between 2.5 and 3.5 inches at the door sill. Trailers may descend slowly or experience a slight one-time drop from discharge of residual air in the bags as a forklift initially enters the trailer. During cargo transfer, a manual valve limits trailer drop to tire deflection and minimizes walk.

DST® Technology — Another Valve Option

Available on VANTRAAX® systems, DST® Dock Stabilizing Technology™ addresses loading dock issues of trailer drop and walk. DST combines refined suspension geometry, optimized plumbing and our patented HCDDV Height Control Differential Dump Valve.

DST exhausts more than twice as fast as conventional automatic dump valves, and in most cases, brings the trailer to rest on the internal air spring bumpers before the trailer parking brakes fully engage. The trailer deck height thus falls between 2.5 and 3.5 inches, and DST limits trailer drop to tire deflection and minimizes walk without requiring additional driver intervention.



For the fleet owner, this means more efficient trailer loading and unloading.

For additional information:

Loading Dock Approach Procedure — B109

Trailer Loading Dock Terms and Solutions — L816

SURELOK Flyer — L622

DST Dock Stabilizing Technology Flyer — L781

Download current literature at www.hendrickson-intl.com

NO
PARKING
LOADING
ZONE

VALUE ADDED

Features and Options

Where do fleets and owner operators find a competitive advantage today?

Through reduced maintenance, lighter weight and increased durability.

For today's and tomorrow's haulers, Hendrickson fuses quality and innovation into all of its products. Great emphasis is placed on research and development to refine our suspension systems and develop cost-effective options that add enduring value to equipment.

THE HENDRICKSON ADVANTAGE

Hendrickson's INTRAAX® and VANTRAAX® systems exhibit a variety of features and options to help haulers keep one step ahead of the competition. The industry's first standard trailer Cam Tube System™, ZMD® ZERO MAINTENANCE DAMPING®

Technology, an optional factory-applied Soft Coat Finish, our LDA™ Large-Diameter Axle and the UBL™ UNDER BEAM LIFT™ all exemplify Hendrickson's theory of continuous innovation.

Cam Tube System™



Throughout the trucking industry, S-cam journal service life and ease of maintenance remain among the most criticized features of conventional trailer S-cam brake designs. With the addition

of extended-service brake and hub systems, the need arose to extend maintenance intervals and durability of the cam supports to match.

Industry studies reveal that S-cam bushing life is a function of contaminant levels in the areas where the cam journals contact the bushings. The basic design principle behind our Cam Tube System™ is to keep contaminants away from the camshaft. The Cam Tube System includes a modular steel cartridge that encloses the S-cam shaft on each wheel-end assembly. We encase the camshaft support bushings and seals at each end of this cartridge.

The spring-loaded seals greatly limit the potential of contaminant entry by providing two redundant barriers to entry. Ozone seal resistant material prevent degradation by sustaining the life of the rubber. This system holds seven times more grease than conventional designs. Any debris

passing the seals becomes effectively diluted, minimizing the potential of damage or wear.

When compared to traditional trailer brake designs that have separate seals surrounding each journal and bushing individually, Hendrickson's Cam Tube System reduces contaminant entry points by 50 percent.

(See Cam Tube System flyer — L1214 for additional information.)

ZMD® ZERO MAINTENANCE DAMPING®

ZMD® is available as a premium on select VANTRAAX® and INTRAAX® integrated air suspension systems and as a standard component on ULTRAA-K® integrated air slider suspension systems. ZMD technology eliminates shock absorbers all together and integrates the damping function traditionally performed by the shock within the air spring itself. ZMD air springs exchange pressurized air through channels that interconnect the bellows and piston of this patent-pending air spring.

Unlike a shock absorber whose damping capacity is finite and deteriorates with age, ZMD air springs are designed to provide continuous damping rates over the life of the air spring. Robust chain down stops provide maximum durability which helps reduce labor costs and maintenance over the life of the trailer.

(See ZMD flyer — L1209 for additional information.)

AIR SUSPENSIONS



LDA™ Large-Diameter Axle

Since the first handcart, haulers sought lighter weight equipment — more often than not by substituting lighter materials and sacrificing strength for a weight reduction. Hendrickson developed the LDA™, a 5-3/4-inch axle that reduces trailer suspension weight while actually improving component and system strength. By increasing the diameter of the traditional 5-inch axle by about three-quarters of an inch, it allows for the use of a thinner axle wall.

The standard axle diameter in Europe, the road proven LDA tube allows the use of a slightly thinner wall for a more efficient application of materials. In other words — there is significant weight savings and increased bending and torsional stiffness with comparable overall strength to a 5-inch axle tube.

LDA generates a weight savings of between 20 and 27 pounds for each axle, depending on axle capacity. In addition to matching the structural durability of the 5-inch tube, the larger diameter increases bending and torsional stiffness by more than 14 percent. The reduced tube deflection keeps the axle straighter under loads to help improve fuel efficiency and enhance tire life. Greater torsional rigidity also boosts roll stability.

As the largest trailer axle manufacturer in the North American market, Hendrickson's state-of-the-art production capabilities such as friction-welded spindles and induction hardening allow us to manufacture superior axles known for their unmatched straightness and consistent construction.

LDA features the same neutral-toe alignment and long lasting heat-treated components as our 5-inch axles and are available with HN and HP spindles, as well as an array of wheel-end options.



UBL™ UNDER BEAM LIFT™

Hendrickson's UBL™ UNDER BEAM LIFT™ lets fleets and owner-operators put the advantages of INTRAAX® to work in liftable applications. Liftable axles offer operational flexibility, extend tire life, improve trailer maneuverability, allow vehicles to carry more payload and can even save on road tolls. The UBL is a sturdy, lightweight and easy-to-install lift mechanism. When combined with INTRAAX, UBL provides the lightest integrated lift system available today, increasing your productivity and profitability.

(See UNDER BEAM LIFT flyer — L727 for additional information.)

Soft Coat Finish / Hot Dip Wax

Harsh road and weather conditions take their toll on equipment. With many fleets extending trade-in cycles for equipment, haulers look for ways to extend the life of their trailers. Hendrickson's factory-applied Soft Coat Finish and Hot Dip Wax are coatings that enhance resistance to corrosion and rust, keeping suspensions on the road longer.

When stone chips occur on conventionally painted suspensions, water can migrate under the paint leading to rust and corrosion. Remaining soft and pliable, Hendrickson's Soft Coat Finish and Hot Dip Wax option cushion impacts from road debris to yield a surface less susceptible to chipping.

Before final assembly, Soft Coat Finish is robotically applied and Hot Dip Wax is dipped on clean, non-primed surfaces covering all hard-to-reach areas. This process replaces the finished coat process. Soft coat paint and hot dip wax withstands accelerated corrosion tests, passing 2,000 hours in a salt-spray environment. This exceeds the capacity of most finishes used in the industry today.

Soft Coat is an available option on INTRAAX and VANTRAAX® integrated air suspension systems. Hot Dip Wax is only available on ULTRAA-K® integrated air slider suspension systems.

EXTENDED-SERVICE Wheel-End *Options*

As fleets and owner operators focus on reducing operating costs, maintenance intervals and warranty costs, extended-service wheel-ends offer excellent potential to fulfill goals pertaining to cost reductions.

Wheel-end Damage

Two main factors contribute to wheel-end damage:

High Operating Temperatures: The primary method to reduce wheel-end operating temperature is lubrication. Poor quality or lack of lubricant can damage wheel ends.

Contamination: Contaminants not only affect the integrity of the lubricants but can be critical to the life of the wheel seal as well. There are four primary conduits for contaminants to enter the wheel-end:

- *A damaged or worn seal can create a pathway for contaminants to enter and for lubricants to exit the wheel-end. Proper seal installation is vital to the life*

and performance of the seal. When replacing a seal, follow the seal manufacturer's instructions to ensure proper seal positioning.

- *Improper bearing adjustment may result in excessive end play or preload, either of which can shorten bearing life. Excessive end play could also shorten seal life.*
- *Water can enter the hubcap by way of the ventilation ports, thus compromising the integrity of the lubricant. Also, leakage around the mounting surface can occur if hubcap bolts are not installed to the proper torque specification.*
- *Contamination of the wheel-end interior prior to initial installation can also compromise service life. This type of contamination is commonly overlooked during the installation process due to the misconception that "because the hub is new, it is clean inside."*

THE HENDRICKSON ADVANTAGE

Hendrickson Trailer Commercial Vehicle Systems provides fully integrated suspensions including extended-service wheel-ends. Integrated, modular systems present an opportunity to enhance end-user value in the area of maintenance and operating expenses, as well as improve productivity and operating efficiency. These fully integrated systems also provide the customer with a single source supplier. The following items are contributors to our quality wheel-end products:

- **Companion Parts** — *Hendrickson applies stringent screening requirements and techniques to ensure that only high quality, dependable wheel-end components are offered.*
- **Quality Control** — *Clean and dry storage is provided for all wheel-end components.*
- **Skilled Labor Force** — *Hendrickson's skilled and qualified personnel combined with our quality control programs allow us to offer outstanding extended wheel-end warranty coverage.*
- **Production Control Systems** — *Detailed wheel-end installation procedures are controlled throughout the assembly process. No detail is overlooked to provide the finest quality assembly.*

AIR SUSPENSIONS



RTR® READY-TO-ROLL® wheel-end packages offer a variety of extended-service options and a wide array of individual components that allow fleets and owner operators to customize their running gear to meet specific needs and requirements.

HXL Hendrickson Extended-Life wheel-end packages are designed for low maintenance and long life and offer the convenience of a single supplier for support and peace of mind from the most trusted name in the trailer industry.

Properly installing wheel ends requires time, manpower, and most importantly, attention to detail. Our certified wheel-end technicians take the time to ensure that HXL components like spindle nuts, bearings, seals, hubs, lube, hub caps, drums and dust shields are installed the right way every time.

Hendrickson's Extended-Life wheel-end packages include our patented PRECISION spindle nut system. This innovative 2-piece spindle nut system provides fine-tuned adjustment increments to achieve more precise end play settings than traditional and more complicated 3-piece spindle nut systems.



**HXL7®
Wheel-end**

**PRECISION240®
nut system**

PRECISION nut systems have nearly five times the adjustment resolution of other similar systems and guarantee that bearings are set correctly the first time. Hendrickson installs PRECISION nuts using state-of-the-art equipment, allowing us to achieve precise adjustment in light preload, which maximizes seal and bearing life.

(See READY-TO-ROLL WHEEL ENDS flyer — L1200 for additional information.)

		HXL3®	HXL5®	HXL7®
Spindles		HN / HP	HN / HP	HP Only
Limited Warranty*	On-highway	3-Year	5-Year	7-Year
	Off-highway	1-Year	3-Year	3-Year
Hub Material	Ductile Iron	X	X	X
	ADI	X	X	X
	Aluminum	X	X	X
Lube Type		SAE 80/90 Gear Oil or 75-90 Synthetic	Semi-fluid Grease	Semi-fluid Grease
Hub Cap		Ventless Bolt-on	Ventless Bolt-on	Ventless, Corrosion-resistant Bolt-on
Features	Patented Ventilation System	X	X	X
	PRECISION Spindle Nut	X	X	X
	Allows for wide base tires with 2-inch offset rims	HP Only	HP Only	X
TIS Capable**		TIREMAAX® PRO & CP	TIREMAAX PRO & CP	TIREMAAX PRO & CP

* Contact your local Hendrickson representative for complete warranty terms, conditions and limitations.

** Spec'ing TIREMAAX does not affect wheel-end package warranty. TIREMAAX warranty matches the wheel-end package warranty.

Brake Efficiency

In the North American market, rapidly advancing vehicle technology enables tractors and trailers to become increasingly aerodynamic and more fuel-efficient. Simultaneously, the economic realities of the trucking industry lead fleets to demand reductions in periodic maintenance and elimination of major maintenance issues.

As fleets and owner operators strive to increase vehicle efficiency and reduce maintenance costs, they must remember that improvements in one area can reveal weaknesses or inefficiencies in another or hinder overall system performance.

In vehicle braking systems, the very factors that dramatically increase vehicle performance also cause brake workloads to increase substantially.

While they may have more than 75 years of design heritage, today's S-cam foundation brake system must "work harder" to meet the demands of modern trailers by more efficiently utilizing air system capacity and maximizing available air chamber actuation stroke. The future holds even greater changes for the vehicle braking system as new regulations and technologies shape the demands of vehicle designs.

THE HENDRICKSON ADVANTAGE

Since 1995, Hendrickson has delivered more than a million brakes to satisfied customers on our INTRAAX® and VANTRAAX® systems. We back all our brakes with extensive performance tests and heavy wear test data. Hendrickson stands ready to assist OEMs and fleets to choose the right braking solution.

At the heart of our advanced S-cam brake design, a sophisticated manufacturing process provides extremely accurate centering of the foundation brake spider to the axle. This results in stable, repeatable brake torque from wheel-end to wheel-end.

Our forged spider design adds material only where needed and removes it where it is not. This results in a best-in-class lightweight spider with excellent structural characteristics.

HXS® Hendrickson Extended Service™ brake shoes optimize geometry to further improve brake balance. Our crown geometry maintains consistent and balanced

brake torque on both sides of the axle during the break-in period.

HXS brake shoes use .313-inch thick steel webs with heat-treated roller and anchor pins slots for durability and dimensional stability over the life of the shoe. E-coat paint helps prevent rust jacking.

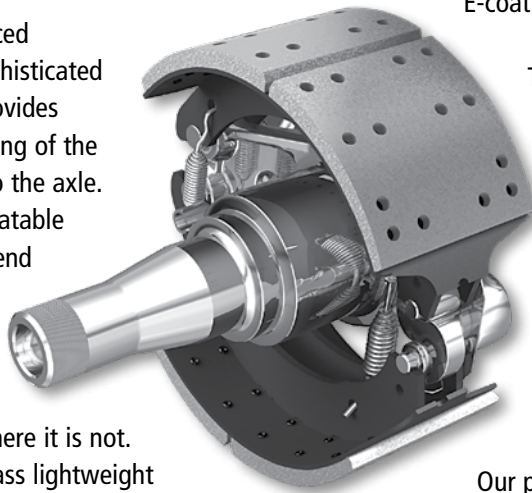

To eliminate wasted deflection in the actuator support system, Hendrickson's unique, air chamber bracket comes integrally welded to the suspension trailing arm, which also incorporates a rigid inboard cam support. Besides having very low deflection, the Hendrickson design eliminates the air chamber bracket and cam support welds on the axles — points where other axles commonly fail.

Our patented integrated suspension beam / brake connection allows for a shorter camshaft that results in less twisting deflection. This means a shorter brake stroke generates the required braking force.

AIR SUSPENSIONS



Other benefits of reduced brake stroke include:

- Less air consumption during ABS actuation
- Faster application and release times
- More efficient actuation geometry under high-brake application pressures
- Enhanced brake reserve when operating in mountainous terrain
- Increased brake reserve during burnishing-in period for new linings
- Maintaining brake adjustment longer — helps avoid out-of-adjustment traffic citations

Hendrickson integrated brake systems come in a variety of models and options that can be tailored to the needs of each fleet. These include:

16.5- x 7-inch standard

Available with many industry-standard lining materials, the standard brake is our robust basic performance product.

16.5- x 7-inch HXS®

The extended service brake of choice for trucking professionals, HXS brakes may be spec'd with industry accepted long-life lining materials.

Hendrickson's wide HXS brakes provide 11 percent more wearable lining volume than competitors' 16.5- x 8.625-inch wide brake. Wide HXS brakes may be spec'd with industry accepted long-life lining materials.

16.5- x 8.625-inch wide HXS

Hendrickson's wide HXS brakes advance extended service. Offering 58 percent more wearable lining volume and 23 percent greater swept area than standard brakes, 16.5- x 8.625-inch HXS brakes dramatically extend lining life.

15- x 8.25-inch wide HXS

Engineered specifically for low-ride height applications such as furniture vans and car haulers, Hendrickson's 15- x 8.625-inch wide HXS brakes work with 19.5-inch wheels.

Building on a Solid Foundation

To complete the best trailer braking system on the market today, Hendrickson also offers a full line of automatic slack adjuster and air chamber options. Of special note are long-stroke chambers, which allow end users and fleets to achieve the maximum stroke reserve available in the industry.

For additional information:

Consolidated Certificate of Compliance for Air Actuated Brakes — L809 E-coat brochure — L1205

Download current literature at www.hendrickson-intl.com

Vehicle Controls

As integrated air suspension systems become more complex, fleets and owner operators seek effective tractor-trailer pneumatic and electronic control mechanisms to take full advantage of system capabilities. Hendrickson offers an array of controls including height control valves, manual dump valves and lift axle controls.

In addition to these controls, many haulers want devices to check trailer load weight; conveniently release slider pins; and automatically or remotely trigger lift axles, dump valves and warning devices.

THE HENDRICKSON ADVANTAGE

Hendrickson delivers an array of vehicle control devices to customize suspension operations for specific requirements of fleets and owner operators.

Two popular devices from Hendrickson are the Automatic Lift Axle Control Kit and an automatic Back-up Alarm System. Both exemplify innovative approaches to solving industry concerns.

The Automatic Lift Axle Control helps Canadian haulers comply with infrastructure-friendly regulations and eliminates

the operator's role in raising and lowering self-steering trailer lift axles. It triggers the axle lift mechanism when the trailer travels rearward and starts the axle dropping with forward movement.

Compatible with any lift mechanism equipped with an electro-pneumatic control, the device's wheel-end sensor reads the ABS tone ring, triggering after three feet of rearward travel to activate the lift mechanism. Eighty feet of forward travel automatically keys the lowering of the axle.



The Automatic Lift Axle Control eliminates the operator's role in raising and lowering self-steering trailer lift axles.

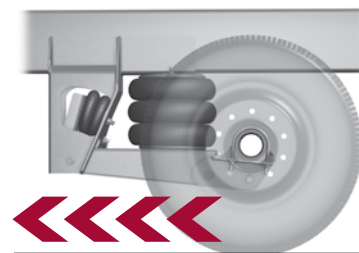

Moving forward 80 ft. automatically triggers lowering of the axle.

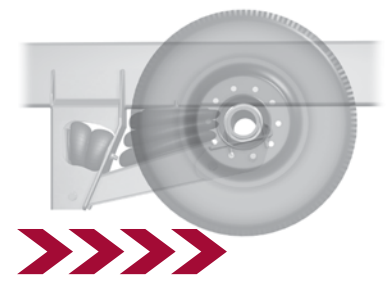

Moving in reverse 3 ft. automatically keys lifting of the axle.

AIR SUSPENSIONS

Hendrickson's automatic trailer Back-up Alarm System helps improve awareness of backward vehicle movement in areas of limited maneuverability and visibility. The easy-to-install, stand-alone, automatic system requires no communication with the tractor.



The automatic trailer Back-up Alarm System helps improve awareness of backward vehicle movement in areas of limited maneuverability and visibility.

With rearward trailer movement, the system activates a very loud warning sound to alert bystanders and other drivers that the vehicle is moving in reverse. This can be beneficial in areas such as crosswalks and congested dock operations.



For additional information:

Controls Parts Catalog — L1182

Download current literature at www.hendrickson-intl.com

Hendrickson Vehicle Controls

Simple, effective solutions for trailer electronic and pneumatic control needs



Manual Lift Axle Control

Automatic Lift Axle Control

Height Control and Dump Valves

Tire Inflation Systems

Back-up Alarm

Aftermarket

Like most industries, heavy-duty transportation struggles with hit-and-miss aftermarket component manufacturers. Be it toasters, lawnmowers, automobiles or Class 8 rigs, the respective aftermarkets are full of look-alike and knock-off repair parts, many of poor quality.

Knock-offs often attract customers with cheaper pricing than components manufactured and distributed by OEMs. That cost savings can evaporate quickly if the look-alike part does not fit correctly. Using look-alike parts can cause suspension components to fail prematurely,

which increases labor time and produces unexpected downtime.

Ill-fitting replacement components may also minimize the performance of original equipment or degrade overall wear and reliability, increasing costs. OEMs support equipment with OE specified parts and equitable warranties. Use of knock-off parts and components, in many cases, can void equipment warranty.

THE HENDRICKSON ADVANTAGE



Over the decades, Hendrickson has manufactured hundreds of thousands of air suspensions and integrated suspension, axle and brake systems for trailers. Suspensions are designed using

quality components and submit those components to rigorous testing and stand behind Hendrickson Genuine Parts, just as we stand behind our suspension systems.



Air springs, shocks, bushings, axles, brake systems and air controls — all our components function in unison to provide superior system performance. Insisting on Hendrickson Genuine Parts

ensures the continued reliability and performance you have come to expect from Hendrickson.

For example, differences in air spring piston design, flex member length and overall dimensions may not be obvious but are critical to performance. Other critical dimensions not readily visible include variations in internal bumpers and flex member bias angles.

Hendrickson pioneered the use of a single, large-diameter bushings in air suspensions with our original TRI-FUNCTIONAL® Bushing. Unique void designs and material composition remain critical to maintaining outstanding performance on the road.



TRI-FUNCTIONAL® Bushings

AIR SUSPENSIONS



With INTRAAX®, Hendrickson introduced a more efficient brake system using beam-mounted hardware and shorter S-cams. In addition to standard brakes, we offer HXS® Hendrickson Extended Service™ brake shoes to enhance lining life while optimizing geometry and further improving brake balance (see page 22).

Hendrickson designs shocks with specific strokes, seal designs, bore diameters and damping characteristics to enhance suspension system performance. A shock with too short a stroke may cause mounting clevises or trailer cross member damage; too long a stroke can cause overextension of the system and damaged air springs.



The aftermarket list goes on and on — the unique QUIK-ALIGN® pivot connection with a specially developed shear type bolt is another component that is specifically designed to work with air suspension systems. Look-alike parts could result in insufficient torque.

Insist on Hendrickson Genuine Parts to maximize uptime and minimize your operation costs.

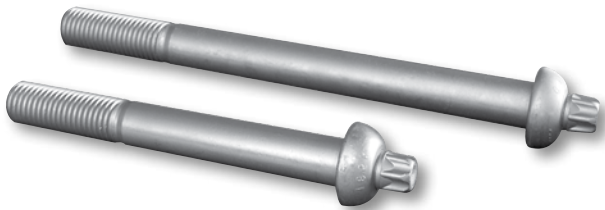

Hendrickson HCV aftermarket kits

- VS-227 replacement HCV fits all trailer air suspensions excluding ULTRAA-K® axle / suspension air slider systems regardless of make, model or year.
- VS-33704-3 replacement HCV fits ULTRAA-K models



For additional information:

Hendrickson Genuine Parts — L595
Genuine Parts Flyer, Air Spring — L1019
Genuine Parts Flyer, Shocks — L1020
Cam Tube System Flyer — L1214
HCV Brochure — L1024

Download current literature at www.hendrickson-intl.com



TRAILER Air Suspension *Slider Systems*

Benefits

- VANTRAAX® combines the advantages of INTRAAX® with the patented K-2® slider box
 - Low maintenance
 - Cam Tube System™ for trailer brake systems
 - TRI-FUNCTIONAL® bushings — proven technology for mile after mile of trouble-free service
 - Neutral-toe axle — improved mileage and tire life
 - Advanced axle wrap and window weld for optimal structural integrity
 - 10-year limited warranty* on axle/beam connection
 - 5-year limited structural warranty*
 - Broad mix-and-match RTR® READY-TO-ROLL® offerings let you customize your running gear to meet your specific requirements
 - Single source for comprehensive technical support, training and warranty
- * Contact your local Hendrickson representative for complete warranty terms, conditions and limitations

ULTRAA-K® UTKNT 40K

Lightweight tandem air slider technology

- **Application:** Refrigerated and vans
- **System capacity:** 40,000 pounds
- **Ride height:** 16 inches
- **Box widths:** 48 inches
- **Axle spread:** Standard 49-inch closed-space tandem
- Standard with ZMD® ZERO MAINTENANCE DAMPING®, shockless suspension system technology
- Standard with QUIK-DRAW®
- Pivoting mud flaps help prevent mud flap damage and reduce component maintenance
- Standard LDA™ Large-Diameter Axle provides heavy-duty performance from an ultra-light axle



VANTRAAX® HKANT 23K • 40K • 46K / HKAT 50K

A comprehensive system for dry-freight, refrigerated and specialty vans

- **Application:** Lightweight, road-proven integrated systems for virtually any trailer design using a sliding bogie — optimized for dry-freight, refrigerated and specialty vans
- **System capacity:** 23 • 40 • 46 • 50,000 pounds
- **Ride height:** 16 or 17 inches
- **Box widths:** 42, 48 and 54 inches
- **Axle spread:** Standard 49-inch closed-space tandem; optional 121-inch widespread on select models accommodates 96- or 102-inch trailer widths and four- or six-inch pinhole configurations
- Standard with QUIK-DRAW
- Standard LDA Large-Diameter Axle provides heavy-duty performance from an ultra-light axle



AIR SUSPENSIONS



VANTRAAX® TRIDEM **HKANT 69K23 • HKAT 69K25**

- **Application:** Dry, refrigerated and specialty vans
- **System capacity:** 69,000 pounds
- **Suspension capacity:** 23 • 25,000 pounds
- **Ride heights:** 16 and 17 inches
- **Box width:** 42 and 48 inches
- **Axle spread:** 60 and 72 inches, 49 inches for HKANT 69K23
- Allows haulers to go through state and international borders while maintaining compliance
- Standard LDA™ Large-Diameter Axle provides heavy-duty performance from an ultra-light axle



VANTRAAX Ramp Ready **HKARL 46K**

- **Application:** Haulers delivering where a loading dock is not always possible
- **System Capacity:** 46,000 pounds
- **Ride Height:** 9, 10, 11 or 12 inches
- **Box Width:** 48 inches
- **Axle Spread:** 49 inches
- **Features:** 30 × 6.5-inch ramp bay
- Eliminates heavy, expensive spacer tubes
- Standard LDA Large-Diameter Axle provides heavy-duty performance from an ultra-light axle

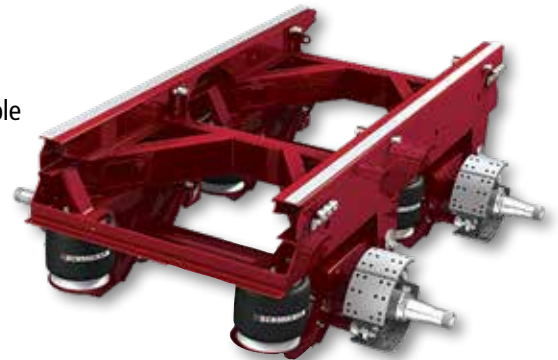

INTRAAAX®-SP **AAZNT 23K • 46K • 69K TRIDEM / AAZL 23K • 46K**

Platform Slider Series

Fits neatly between trailer I-beams. Single-axle and tandem configurations give platform slider operators low-maintenance benefits, unprecedented weight savings and all the benefits of INTRAAAX®.

- **Application:** Straight and drop-deck platform trailers
- **System Capacity:** 23 • 46 • 69,000* pounds
- **I-Beam Centers:** 37, 38, 43 and 44 inches
- **Axle Spread:** 49, 60 and 72 inches
- Saves as much as 800 pounds compared to comparable air suspension sliding tandems and 200 pounds compared to mechanical sliders
- Standard with brake chamber powered QUIK-DRAW®
- Standard LDA Large-Diameter Axle provides heavy-duty performance from an ultra-light axle (AAZL only)

*AAZNT models only



TRAILER

Suspensions *Primary*

Benefits

- Low maintenance
- Cam Tube System™ for trailer brake systems
- TRI-FUNCTIONAL® bushings — proven technology for mile after mile of trouble-free service
- Neutral-toe axle — improved mileage and tire life
- Advanced axle wrap and window weld for optimal structural integrity
- 10-year limited warranty* on axle / beam connection
- 5-year limited structural warranty*
- Broad mix-and-match RTR® READY-TO-ROLL® offerings let you customize your running gear to meet your specific requirements
- Single source for comprehensive technical support, training and warranty

* Contact your local Hendrickson representative for complete warranty terms, conditions and limitations

INTRAAX® Top-mount AANT 23K

The definitive system for weight-conscious haulers

- **Application:** Straight-frame platforms, container chassis, liquid tankers, bulk tankers, bottom dumps, grain and livestock trailers
- **Capacity:** 23,000 pounds
- **Ride heights:** 12 to 19 inches
- Trims an average of 50 pounds from what was already the lightest, toughest integrated suspension-axle-brake system
- Tapered hanger design allows installation without additional gussets on trailer frames as narrow as four-inches, giving improved installation efficiency
- Standard LDA™ Large-Diameter Axle provides heavy-duty performance from an ultra-light axle



INTRAAX Top-mount AAT 23K • 25K • 30K

Reducing weight, improving ride, minimizing maintenance and maximizing productivity

- **Application:** Ideal for platforms, tankers, dumps and loggers
- **Capacities:** 23 • 25 • 30,000 pounds*
- **Ride heights:** 13.5 to 19 inches
- Standard LDA™ Large-Diameter provides heavy-duty performance from an ultra-light axle
- Lightest in its class

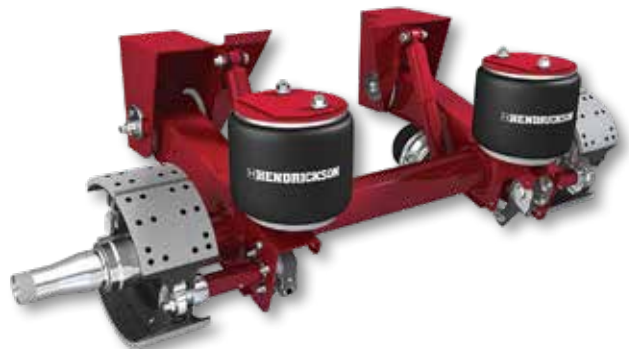

* Axle capacity 25,000 pounds

AIR SUSPENSIONS



INTRAAX® Low-ride / Lifiable AANL 23K • AAL 23K • 25K • 30K

Designed specifically for low-ride heights and liftable axles

- **Application:** Ideal for configurations including platforms, dumps, drop-decks, tankers, B-trains, livestock trailers and specialty trailers
- **Capacities:** 23 • 25 • 30,000 pounds*
- **Ride heights:** 6.5 to 19 inches (AAL)
6.5 to 17 inches (AANL)
- Lightest integrated liftable system available
- Compact UBL™ UNDER BEAM LIFT™ allows for closer axle spacing
- Standard LDA™ Large-Diameter Axle provides heavy-duty performance from an ultra-light axle

* Axle capacity 25,000 pounds



INTRAAX Extreme-duty AAEDT / AAEDL 30K

Extreme-duty top-mount and low-ride systems provide the muscle needed for toughest off-road and heavy-hauling applications

- **Application:** Raw wood trailers including loggers and chip vans; dumps, tankers, straight- and drop-deck platforms and specialty trailers
- **Capacity:** 30,000 pounds — suspension and axle
- **Ride heights:** Top-mount, 14 to 17 inches / low-ride, 9 to 19 inches
- The first integrated 30,000 pound structural and axle capacity system for severe-duty and heavy-hauling operations
- Low-pressure air springs with steel pistons and full bottom plate coverage
- High-damping, extended-service shock absorbers
- Heavy-duty options include rear-mount shock absorbers and chain down-stops



INTRAAX AAEDT

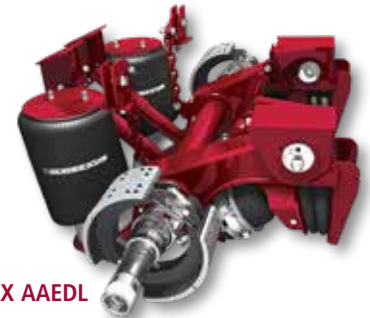

INTRAAX AAEDL

INTRAAX Compact Low-ride AANLS 20K

Brings advantages of system integration in a highly compact, low-ride height suspension

- **Application:** Auto haulers, moving vans and drop frame trailers
- **Capacity:** 20,000 pounds*
- **Ride heights:** 6.25 to 12 inches
- Compact package ideal for the tight confines of the auto hauler and drop-frame trailer designs
- System accepts 15- or 16.5-inch brakes allowing choice of 19.5- to 24.5-inch tires
- Air suspension package more than 120 pounds per axle lighter than comparable suspensions

* Axle capacity 25,000 pounds



TRAILER

Suspensions *Self-Steer*

Benefits

- Standard with RTR® READY-TO-ROLL® wheel-end packages
- Available with TIREMAAX® automatic tire inflation systems
- QUIK-ALIGN® pivot connection — helps simplify axle alignment
- TRI-FUNCTIONAL® bushings — proven technology for mile after mile of trouble-free service

CONNEX™-ST

Trailer self-steer suspension system

- **Application:** Ideal for multi-axle trailer applications
- **Capacity:** 25,000 lbs.
- **Ride heights:** 14 to 19 inches
- Assists with compliance of Ontario SPIF regulations
- Helps increase maneuverability



CONNEX™ CXU 23K / 25K

Unitized Air Suspension and Axle System

- **Application:** Low-ride height applications that require 12.25-inch drum brake package
- **Capacities:** 23,000 and 25,000 lbs.
- **Ride heights:** 5.5 to 6.5 inches
- Galvanized frame bracket option for bolt-on frame brackets

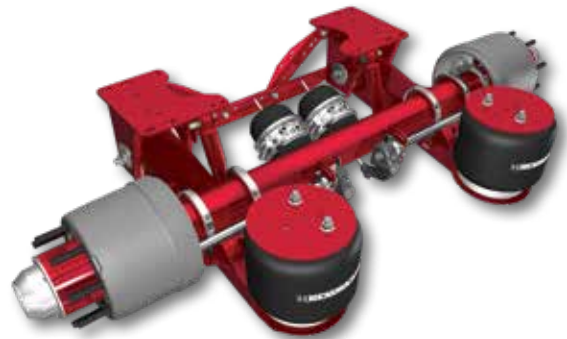

AIR SUSPENSIONS

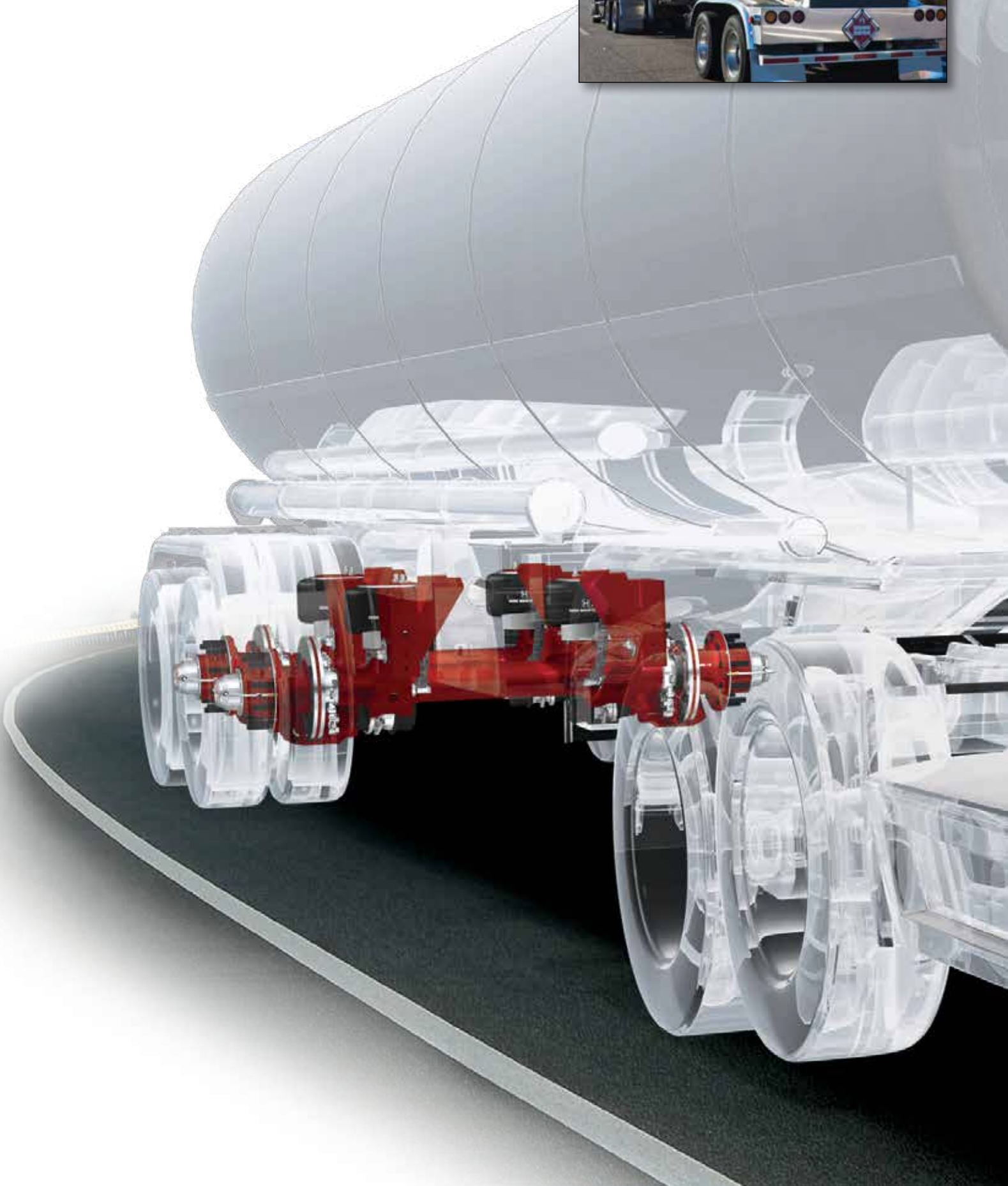

UNDERSTANDING

Common Components of an Integrated Air Suspension System

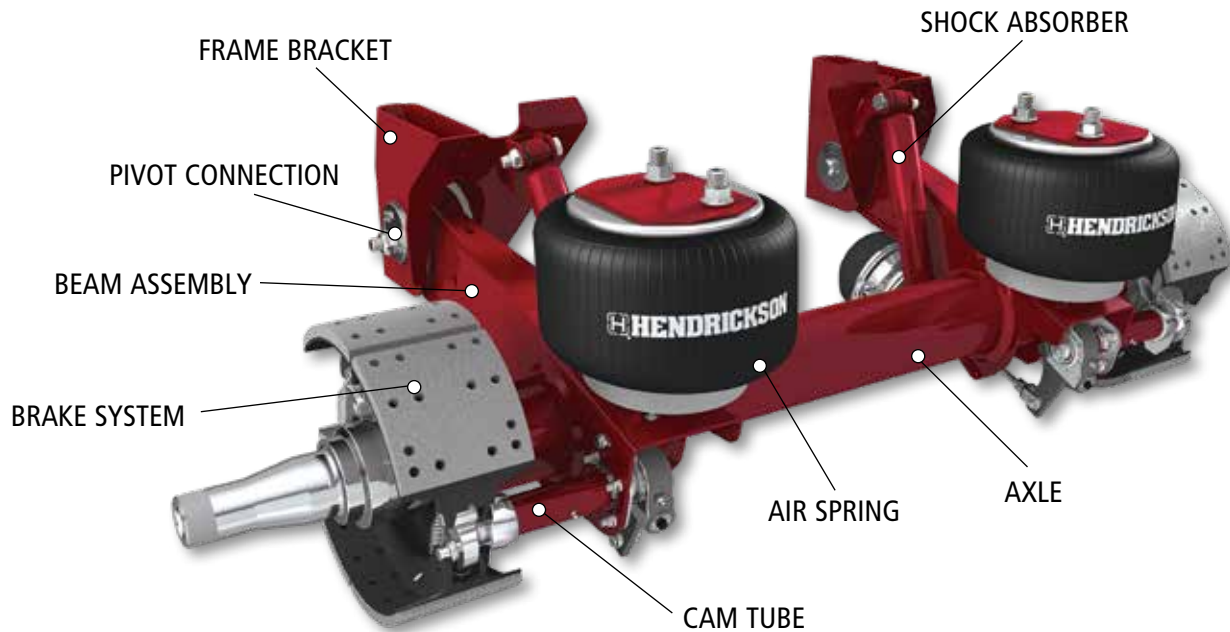

Standard Terminology

Air Spring Terminology

AIR SPRING: An inflatable bag designed to hold a volume of air. Sometimes referred to as air bag. Supports the trailer with air pressure.

FLEX MEMBER: Inflatable rubber portion of the air spring.

PISTON: Bottom portion of the air spring that attaches to the flex member. Used to mount the air spring to the suspension beam

BEAD PLATE: Mounting surface of the air spring that is attached to the flex member.

Axle Terminology

AXLE TRACK: The lateral distance between the center of the dual tires on an axle.

HN SPINDLE: Similar to the D22 or TN spindle. A tapered spindle with small outer wheel bearings and large inner wheel bearings.

HP SPINDLE: Similar to the P22 or TP spindle. A straight spindle with the same inner and outer wheel bearings.

LDA™ LARGE-DIAMETER AXLE: Replaced typical 5-inch axle with a 5.75-inch diameter.

Beam Terminology

BEAM ASSEMBLY: Sometimes referred to as walking beams or trailing arms. Load carrying structure that pivots at the frame bracket, connects to the axle tube and the air spring.

“Y” BEAM: Suspension beam assembly that straddles the trailer frame at the pivot.

Frame Bracket Terminology

FRAME BRACKET: Sometimes referred to as hangers, towers or support boxes. Load carrying structure that bolts or welds to the trailer frame and attaches to the beam assembly at the pivot connection.

WINGED FRAME BRACKET: A frame bracket with an integral gusset on the inside rear surface for lateral support.

WINGLESS FRAME BRACKET: A frame bracket that does not include an integral gusset. Typically uses a separate 3-inch C-channel to provide lateral support.

AIR SUSPENSIONS



WELD-ON FRAME BRACKET: A frame bracket that welds to a steel trailer frame.

BOLT-ON FRAME BRACKET: A frame bracket with holes in the top plate for bolting to an aluminum frame.

WELDABLE BOLT-ON FRAME BRACKET: A frame bracket that bolts to an aluminum frame using OEM provided mounting plate.

General Terminology

RIDE HEIGHT: Distance from the center of the axle to the mounting surface of the suspension (bottom of trailer frame or slider frame) at normal operating position.

JOUNCE: The maximum upward motion of the axle from ride height toward the frame, including bumper compression.

REBOUND: The maximum amount of downward axle travel allowed by the suspension; controlled by the shock absorber.

TOP MOUNT: A suspension where the beam assembly is on top of the axle.

UNDERSLUNG: A suspension where the beam assembly is under the axle.

TRI-FUNCTIONAL® BUSHING: Rubber bushing located in the beam assembly of the pivot connection. Controls horizontal, vertical and roll forces on the vehicle.

SHOCK STRAP: Strap that is mounted around the shock that is used to provide additional strength for limiting rebound.

PIVOT BOLT: The bolt that attaches the beam assembly to the frame bracket at the pivot connection.

WELDED ALIGNMENT: Suspension alignment connection where the alignment is secured by welding.

QUIK-ALIGN®: Suspension alignment connection where the alignment is adjusted using an eccentric alignment washer and secured by torquing the pivot bolt.

LOADED TIRE RADIUS: The distance between the axle spindle centerline and the ground when the vehicle is in its loaded condition. Determined by the size and design of the tire.

Hendrickson Product Terminology

T SERIES: Hendrickson's first trailer suspension products. Offered in various capacities and configurations.

HT™ SERIES: Hendrickson's improvement on the T model; similar capacities and configurations.

CONNEX™-ST: Trailer self-steer suspension system.

INTRAAX®: Hendrickson's integrated axle, beam assembly and brake system.

INTRAAX®-SP: A durable and low maintenance slider system designed specifically for platform and drop-deck trailers.

VANTRAAX®: Air suspension slider systems. Marries our superior K-2® slider box technology with the patented INTRAAX integrated suspension / axle / brake system.

SURELOK®: A device used to maintain trailer deck height during loading and unloading. Also used in place of a dump valve to protect against trailer walk.

HEIGHT CONTROL VALVE: Sometimes referred to as a leveling valve. An air valve that automatically responds to position of the axle and vehicle frame. It maintains the distance from the centerline of the axle to the underside of the frame ride height.

DUMP VALVE: Air dump or exhaust valve. Added to the trailer suspension air system to exhaust the air from the air suspensions and increase stability during loading and unloading.

LIFT KIT: An air-operated mechanism that is used to raise a trailer axle off of the ground.

BUSHING TOOL: Special tool used to remove and replace the TRI-FUNCTIONAL® Bushing of a beam assembly.

Slider Terminology

SLIDER: Sometimes referred to as a bogie or subframe. Movable suspension mounting used to reposition the trailer axle(s).

BODY RAIL: Steel rail that is mounted to the trailer. Contains holes that align with the slider locking pins.

MANUAL STOP BAR: A bar that is inserted into a set of slider body rails that is used to stop the movement of the slider while being repositioned.

LOCKING PIN: Pin within a slider box assembly that keeps the slider from moving. Retracts to allow for the repositioning of the slider.

Applications

Primary (Fixed) Suspension Application Guide														
Suspension	Converter Dollies		Van Type Trailers				Frame Type Trailers							
	Single Axle	Tandem Axle	Van Type Frt. Van Refrig. Van	Drop Frame Van Furniture Van	Chip Van Highway Transport	Livestock	Platform Trailer Straight Frame	Platform Trailer Drop Frame	Curtain side	Equipment Trailer Lowboy	Extendable Tandem Axle	Extendable Multi-Axle	Container Chassis	Logging Chassis
Chart A For Highway Use, Good Paved Roads, Well Maintained Unpaved Roads														
INTRAAX® Top Mount	AANT 23K	R		O		R	R	R		R		R		R
	AAT 23K													
	AAT 25K		R									R		
	AAT 30K													
	AAEDT 30K													
INTRAAX Low Mount or Liftable	AANLS 20K				R									
	AANL 23K	O		O		O	O	O	R	O			O	
	AAL 23K										O			
	AAL 25K		O								R		O	
	AAL 30K													
CONNEX™ Underslung	CXU 23K	O	O		O				R	O	R	O	O	
	CXU 25K	O	O		O				R	O	R	O	O	
HT™ Series Top Mount	HT190T													
	HT230	O		O		O	O	O		O		O		O
	HT300		O										O	
HT Series Liftable	HT250T			O		O	O	O		O		O	O	O
HT Series Low Mount	HT190U													
	HT250US	O	O		O				O	O	R	O	O	
	HT250YS								O		R			
	HT300YB													
	HT300US													
INTRAAX-SP Plat. Z Rail Sliders	AAZNT 23K							O		O		O		
	AAZL 23K								O	O		O		
	AAZNT 46/69K							R		O		R		
	AAZL 46K								O	O		O		
Chart B For Switchback, Washboard, Rough and Poorly Maintained Roads; Areas with Underdeveloped Infrastructure														
INTRAAX Top Mount	AAT 25K	R	R	O			R	R		R		R	R	R
	AAT 30K													
	AAEDT 30K					R								R
INTRAAX Low Mount or Liftable	AAL 25K	O	O	O	R		O	O	R	O	R			O
	AAL 30K													
	AAEDL 30K					O								O
HT Top Mount	HT300	R	R	O		R	O	O		O			O	R
HT Low Mount	HT300US				O					O	O	O		O
	HT300YB								O		R			
Explanation of Chart Use and Legend														
R	These are the most commonly recommended suspension for this trailer type, however, this may not be correct for all applications: <ul style="list-style-type: none"> • Lesser capacity suspensions are not recommended • Higher capacity suspensions in the category can freely be used and should be used as suspension demands are increased. 													
O	"O" is an optional suspension for each suspension category type.													
	These suspensions are not intended for use in this application.													

AIR SUSPENSIONS

Primary (Fixed) Suspension Application Guide (continued)														
Suspension	Open Top Trailers							Shell Type Trailers ²						Skeleton Type Trailers
	Chip Van Logging Use	Transfer Trailer Tilt or Walking Floor	Belt Unload Rear Discharge	Grain Trailer Hopper Style Highway Use	Grain Trailer Hopper Style Farm Use	Dump Trailer ¹ (Rear and Side Discharge)	Dump Trailer (Bottom Discharge)	Bulk Hopper Tandem Axle	Bulk Hopper 3+ axles and/or B-Train	Tanker Tandem Axle	Crude Oil Tanker	Pup Trailer with single lunette eye	Tanker 3+ axles and/or B-Train and/or "High C.G."	Auto Hauler
Chart A For Highway Use, Good Paved Roads, Well Maintained Unpaved Roads														
INTRAAX [®] Top Mount	AANT 23K			R	R			R	R		R			
	AAT 23K													
	AAT 25K		R			R	R			R		R	R	R
	AAT 30K													
	AAEDT 30K													
INTRAAX Low Mount or Liftable	AANLS 20K													R
	AANL 23K			O	O			O	O		O			
	AAL 23K													
	AAL 25K		O			O	O			O		O		O
	AAL 30K													
CONNEX™ Underslung	CXU 23K			O	O	O	O							
	CXU 25K			O	O	O	O							
HT™ Series Top Mount	HT190T													
	HT230			O	O		O							
	HT300		O			O	O	O	O	O	O		O	
HT Series Liftable	HT250T			O	O		O							
HT Series Low Mount	HT190U													O
	HT250US			O	O	O	O							
	HT250YS													
	HT300YB													
	HT300US							O	O	O	O		O	
INTRAAX-SP Plat. Z Rail Sliders	AAZNT 23K													
	AAZL 23K													
	AAZNT 46K													
	AAZL 46K													
Chart B For Switchback, Washboard, Rough and Poorly Maintained Roads; Areas with Underdeveloped Infrastructure														
INTRAAX Top Mount	AAT 25K		R	R		R		R	R					
	AAT 30K													
	AAEDT 30K	R					R			R	R	R	R	R
INTRAAX Low Mount or Liftable	AAL 25K		O	O		O		O	O					R
	AAL 30K													
	AAEDL 30K	O					O			O	O	O		O
HT Top Mount	HT300	R	O	O		O	O		O	O	O	O	O	
HT Low Mount	HT300US	O					O		O	O	O		O	O
	HT300YB													
Explanation of Chart Use and Legend														
R	These are the most commonly recommended suspension for this trailer type, however, this may not be correct for all applications: <ul style="list-style-type: none"> • Lesser capacity suspensions are not recommended • Higher capacity suspensions in the category can freely be used and should be used as suspension demands are increased. 													
O	"O" is an optional suspension for each suspension category type.													
	These suspensions are not intended for use in this application.													

Applications

UNDERSTANDING

HENDRICKSON SELF-STEER SUSPENSION SYSTEMS APPLICATION GUIDE

Self-Steer Suspension System Application Guide														
Suspension	Converter Dollies		Van Type Trailers				Frame Type Trailers							
	Single ⁴ Axle	Tandem ⁴ Axle	Van Type Frt. Van Refrig. Van	Drop Frame Van Furniture Van	Chip Van Highway Transport	Live-stock	Platform Trailer Drop Frame	Curtain-side	Equipment Trailer Lowboy	Extend-able Tandem Axle	Extend-able Multi-Axle	Container Chassis	Logging Chassis	
Category	Model	Category A For Highway Use, Good Paved Roads, Well Maintained Unpaved Roads												
CONNEX™-ST Self-Steer	CXSL 25K			R		R	R		R		R	R	R	
Suspension	Open Top Trailers							Shell Type Trailers ²						Skeleton Type Trailers
	Chip Van Logging Use	Transfer Trailer Tilt or Walking Floor	Belt Unload Rear Discharge	Grain Trailer Hopper Style Highway Use	Grain Trailer ¹ Hopper Style Farm Use	Dump Trailer ¹ (Rear and side Discharge)	Dump Trailer (Bottom Discharge)	Bulk Hopper Tandem Axle	Bulk Hopper 3+ axles and/or B-Train	Tanker Tandem Axle	Crude Oil Tanker	Pup Trailer with single lunetter eye	Tanker 3+ axles and/or B-Train and/or "High C.G."	Auto Haulers
Category	Model	Category A For Highway Use, Good Paved Roads, Well Maintained Unpaved Roads												
CONNEX™-ST Self-Steer	CXSL 25K			R	R		R			R				

GENERAL NOTES (PRIMARY SUSPENSIONS)

Important application information: *(Footnotes for chart on pages 36-37)*

1. Use of a suspension air exhaust (dump) valve is required for dump trailer applications.
2. Cap style bushing tube spacers are required for logging and tanker applications using AAT and AAL suspensions.
3. For severe operation conditions, the use of a higher capacity suspension is recommended.
4. High Control versions of suspension models are recommended for dollies, single axle pups and single axle/multi-trailer applications.

Contact Hendrickson application engineering for:

- Suspensions used more than three per group
- Special applications/applications not shown
- INTRAAX® AAL in applications where axle loads may exceed the rated capacity such as rear position on end dumps (Do Not Use)
- Review of INTRAAX AANT and AANL applications
- Trailer applications unique to local markets and/or markets outside the USA, Canada and Mexico
- Use of HT™ SERIES suspensions for liftable/steerable applications
- Oil/Gas Field applications

Application information needed for suspension recommendations:

- Trailer type
- Area of operation
- Load per suspension
- Road conditions
- Duty cycle (24/7 or 8/5)
- Number of suspensions per trailer
- Ride height (bottom of frame to axle center)
- Number of lift axles, position on trailer and when they are lifted
- Wheel and tire sizes

UNDERSTANDING AIR SUSPENSIONS

HENDRICKSON AIR SLIDER SUSPENSION SYSTEMS APPLICATION GUIDE

Air Slider Suspension Systems Application Guide														
Category	Model	Pup Trailers		Dry Freight				Reefer				Miscellaneous ⁸		
		Single Axle	Tandem Axle	Single Axle	Tandem Axle 49"	Tandem Axle 102"	Tridem Axle 49", 60" & 72"	Single Axle	Tandem Axle 49"	Tandem Axle 102"	Tridem Axle 49", 60" & 72"	Liftable ¹⁰	Drop Frame Tandem	Ramp Storage Tandem
VANTRAAX® Top Mount Narrow Pivot	HKANT 23K	R		R				R						
	HKANT 40K		R		R				R					
	HKANT 46K ⁵		O		O	R			O	R				
	HKANT 69K23						R				R			
VANTRAAX Top Mount Wide Pivot	HKAT 50K ⁶		O		O				O					
	HKAT 69K25						O ⁹				O ⁹			
VANTRAAX Low Mount or Liftable	HKANL 23K ⁷											R		
	HKAL 46K												R	
	HKARL 46K													R
ULTRAA-K® Top Mount Narrow Pivot	UTKNT 40K		R		R				R					
R	These are the most commonly recommended suspension for this trailer type, however, this may not be correct for all applications: <ul style="list-style-type: none"> • Lesser capacity suspensions are not recommended. • Higher capacity suspensions can freely be used and should be used as suspension demands are increased. 													
O	Optional suspension for each suspension category type.													

5. Recommended for applications with higher continuous loading or use on unimproved road surfaces.
6. Required for trailers domiciled in Mexico.
7. The trailer must be designed to allow for sufficient clearance above the tire for liftable applications.
8. Contact Hendrickson for recommendations for applications not shown.
9. 49 inch spacing not available.
10. All VANTRAAX sliders can be used with an axle lift kit for minimal tire ground clearance. Contact Hendrickson for more information.
11. Capacity of primary suspension system axle, brakes, wheels and tires rated separately.

for **ENGINEERED
EFFICIENCY™**

INTRAAAX®

Value, performance and reliability

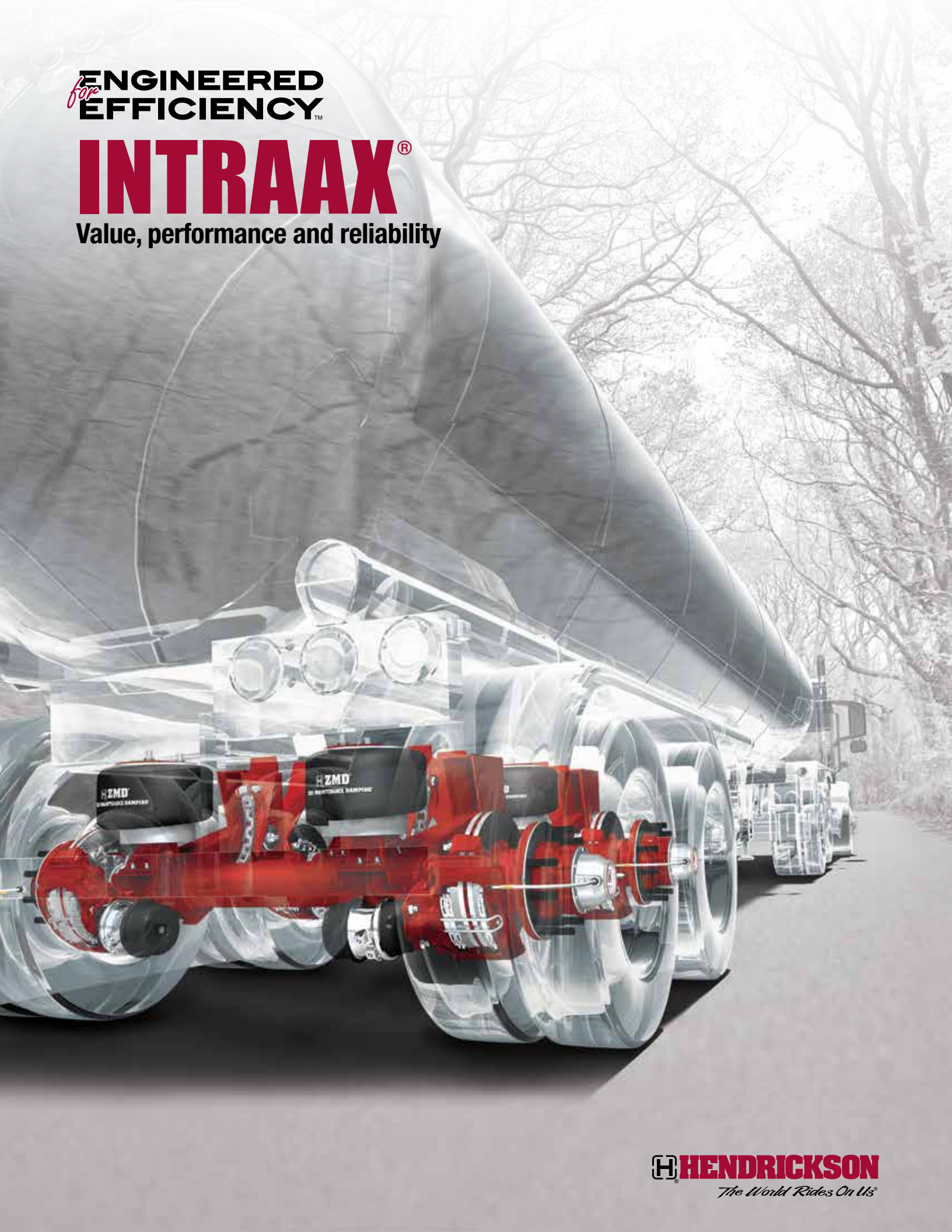

H HENDRICKSON
The World Rides On Us®

UNDERSTANDING TRAILER AIR SUSPENSIONS

At Hendrickson, we commit to serving the transportation industry with innovative products that help improve productivity and profitability. Across the globe, our dedicated employees champion Hendrickson's proud heritage through creativity, integrity and superior service. Our legacy embodies over 100 years as the leading innovator and manufacturer of suspension systems and components for the global medium- and heavy-duty vehicle industry.

Commercial vehicles around the world benefit from our commitment to deliver advanced technologies that are reliable and cost-effective. Our leadership thrives on talented individuals with solid business practices to develop superior, differentiated products that promote leading-edge manufacturing and distribution processes.

Hendrickson leads the advancement of suspension and component technology derived from understanding the needs of fleet and OEM customers. These strategic relationships allow us to engineer and manufacture systems, modules and components that surpass commercial vehicle owners' demands for durability, weight savings and minimized maintenance.



Actual product performance may vary depending upon vehicle configuration, operation, service and other factors.

Call Hendrickson at **330.489.0045** or **866.RIDEAIR (743.3247)** for additional information.



www.hendrickson-intl.com

TRAILER COMMERCIAL VEHICLE SYSTEMS

2070 Industrial Place SE
Canton, OH 44707-2641 USA
866.RIDEAIR (743.3247)
330.489.0045 • Fax 800.696.4416

Hendrickson Canada

250 Chrysler Drive, Unit #3
Brampton, ON Canada L6S 6B6
800.668.5360
905.789.1030 • Fax 905.789.1033

Hendrickson Mexicana

Circuito El Marqués Sur #29
Parque Industrial El Marqués
Pob. El Colorado, Municipio El Marqués,
Querétaro, México C.P. 76246
+52 (442) 296.3600 • Fax +52 (442) 296.3601