

Special Parts Collection – FLORIDA ONLY

Code: 69V8



Subject	Special Parts Collection – Driver & Passenger Seat Mounted Takata Side Airbags
Repair Restriction	Florida Dealers ONLY
Release Date	December 04,, 2018
Affected Vehicles	<p><u>U.S.A.: Certain 2009 MY Volkswagen Tiguan Registered in Florida Only</u></p> <p><i>Check Campaigns/Actions screen in Elsa on the day of repair to verify that a VIN qualifies for repair under this action. Elsa is the <u>only</u> valid campaign inquiry & verification source.</i></p> <ul style="list-style-type: none"> ✓ <i>Campaign status must show “open.”</i> ✓ <i>If Elsa shows other open action(s), inform your customer so that the work can also be completed at the same time the vehicle is in the workshop for this campaign.</i>
Special Parts Collection Program Description	<p>In coordination with the National Highway Traffic Safety Administration (NHTSA), Volkswagen will proactively conduct a special parts collection program involving Takata driver and front passenger seat-mounted side airbags in the State of Florida only, as follows:</p> <ul style="list-style-type: none"> • Driver and front passenger seat-mounted side airbag replacements under this program can only be performed <u>by authorized Volkswagen dealers in Florida</u>. Dealers outside of Florida are <u>NOT</u> eligible to participate in this special parts collection. • Volkswagen will notify approximately 400 owners of 2009 MY Tiguan vehicles registered in Florida and offer to replace the driver and passenger seat-mounted side airbags free of charge. • This program is limited to specific vehicles currently registered and physically located in Florida. These vehicles will be identified in Elsa with Saga code 69V8. • Customers will be advised that, with this program, time is of the essence. After the required number of seat-mounted side airbags have been collected, the program will end. • <u>Both the driver and passenger seat-mounted side airbags must be replaced under this program. <u>Replacing only one side is not allowed.</u></u>
Parts Information	An initial allocation of parts dedicated to this special program will be sent to Florida dealers only, prior to owner notification. Dealers receiving this allocation must ensure it is only used for this program.
Mandatory Parts Return Information	<p style="text-align: center;">IMPORTANT!</p> <p style="text-align: center;"><u>DO NOT</u> detonate the airbags prior to return.</p> <p style="text-align: center;">Airbags <u>MUST</u> be returned intact and remain in their as-removed state.</p> <ul style="list-style-type: none"> • All side airbags replaced under this Action 69V8 must be returned to the designated inspection facility. Requests for all side airbags will be available in the Warranty Parts Portal (WPP) once the claim has reached approved status in SAGA. • Use the Warranty Parts Portal to obtain the FedEx shipping label and required hazardous material documentation. • Side airbags not returned or improperly returned are subject to claim cancellation.
Code Visibility	On or about December 04, 2018, affected vehicles will be listed on the Inventory Vehicle Open Campaign Action report under My Dealership Reports (found on www.vw.com & OMD Web). A list will not be posted for dealers who do not have any affected vehicles.

On or about December 04, 2018, the 69V8 special parts collection code will show open on affected vehicles in Elsa.

On or about December 04, 2018, affected vehicles will be identified with the special parts collection code in the VIN Lookup tool at www.vw.com and on the NHTSA VIN lookup tool at www.safercar.gov.

Owner Notification

Owner notification will take place in early December 2018. An owner letter example is included in this bulletin for your reference.

Additional Information

Please alert everyone in your dealership about this action, including Sales, Service, Parts and Accounting personnel. Contact Warranty if you have any questions.

Dealers outside of Florida are NOT eligible to participate in this special parts collection.

69V8 Claim Entry Instructions

**Due to the special circumstance of this project two claims are required.
A claim must be entered for each criteria.**

*After this action has been completed, please enter a claim as soon as possible using the directions below.
Attach the ELSA screen print showing this action open on the day of repair to the repair order.*

Service Number	69V8															
Damage Code	0099															
Parts Vendor Code	WWO															
Claim Type	7 10															
Causal Indicator	Mark driver seat mounted side airbag as causal part*															
Vehicle Wash/Loaner	Do not claim wash/loaner under this program															
Criteria I.D.	01 (1st claim)															
	Replace Driver Seat Mounted Side Airbag Labor operation: 6958 23 99 190 T.U. <table border="1" style="width: 100%; border-collapse: collapse; margin-top: 10px;"> <thead> <tr> <th style="width: 25%;">Quantity</th> <th style="width: 25%;">Part Number</th> <th style="width: 50%;">Description</th> </tr> </thead> <tbody> <tr> <td>1.00</td> <td>5N0880241K</td> <td>Driver Seat Mounted Side Airbag*</td> </tr> <tr> <td>1.00</td> <td>N 90791201</td> <td>Bolt for Airbag</td> </tr> <tr> <td>Up to 4</td> <td>N 0209022</td> <td>Cable Ties</td> </tr> <tr> <td>Up to 16</td> <td>N 0152612</td> <td>Upholstery Clamp</td> </tr> </tbody> </table>	Quantity	Part Number	Description	1.00	5N0880241K	Driver Seat Mounted Side Airbag*	1.00	N 90791201	Bolt for Airbag	Up to 4	N 0209022	Cable Ties	Up to 16	N 0152612	Upholstery Clamp
Quantity	Part Number	Description														
1.00	5N0880241K	Driver Seat Mounted Side Airbag*														
1.00	N 90791201	Bolt for Airbag														
Up to 4	N 0209022	Cable Ties														
Up to 16	N 0152612	Upholstery Clamp														

Service Number	69V8															
Damage Code	0099															
Parts Vendor Code	WWO															
Claim Type	7 10															
Causal Indicator	Mark passenger seat mounted side airbag as causal part*															
Vehicle Wash/Loaner	Do not claim wash/loaner under this program															
Criteria I.D.	02 (2nd claim)															
	Replace Passenger Seat Mounted Side Airbag Labor operation: 6959 24 99 190 T.U. <table border="1" style="width: 100%; border-collapse: collapse; margin-top: 10px;"> <thead> <tr> <th style="width: 25%;">Quantity</th> <th style="width: 25%;">Part Number</th> <th style="width: 50%;">Description</th> </tr> </thead> <tbody> <tr> <td>1.00</td> <td>5N0880242L</td> <td>Passenger Seat Mounted Side Airbag*</td> </tr> <tr> <td>1.00</td> <td>N 90791201</td> <td>Bolt for Airbag</td> </tr> <tr> <td>Up to 5</td> <td>N 0209022</td> <td>Cable Ties</td> </tr> <tr> <td>Up to 16</td> <td>N 0152612</td> <td>Upholstery Clamp</td> </tr> </tbody> </table>	Quantity	Part Number	Description	1.00	5N0880242L	Passenger Seat Mounted Side Airbag*	1.00	N 90791201	Bolt for Airbag	Up to 5	N 0209022	Cable Ties	Up to 16	N 0152612	Upholstery Clamp
Quantity	Part Number	Description														
1.00	5N0880242L	Passenger Seat Mounted Side Airbag*														
1.00	N 90791201	Bolt for Airbag														
Up to 5	N 0209022	Cable Ties														
Up to 16	N 0152612	Upholstery Clamp														

The repair information in this document is intended for use only by skilled technicians who have the proper tools, equipment and training to correctly and safely maintain your vehicle. These procedures are not intended to be attempted by "do-it-yourselfers," and you should not assume this document applies to your vehicle, or that your vehicle has the condition described. To determine whether this information applies, contact an authorized Volkswagen dealer. ©2018 Volkswagen Group of America, Inc. All Rights Reserved.

Customer Letter Example (USA)

<MONTH YEAR>

<CUSTOMER NAME>

<CUSTOMER ADDRESS>

<CUSTOMER CITY STATE ZIPCODE>

This notice applies to your vehicle: <VIN>

**Subject: Special Parts Collection (69V8) – Driver & Passenger Takata Seat-mounted Side Impact Airbags
Certain 2009 Model Year Volkswagen Tiguan Vehicles Registered in Florida Only**

Dear Volkswagen Owner,

As part of Volkswagen's ongoing commitment to customer satisfaction, we are writing to you today asking you to help us with an important safety and quality assurance initiative.

Volkswagen has pre-selected your vehicle in order to assess the driver and passenger seat-mounted side airbags installed in your 2009 model year Volkswagen Tiguan, and would like to replace these airbags in your vehicle with new parts FREE of charge. This is not a safety recall but, as explained below, is part of an important safety and quality initiative.

REASON FOR THIS SPECIAL PARTS COLLECTION PROGRAM

- While your vehicle is not subject to a recall, Volkswagen seeks to analyze the seat-mounted side airbags in your vehicle out of an abundance of caution. In order to do this, the driver and passenger seat-mounted side airbags currently in your vehicle will be removed and new (replacement) parts will be installed FREE of charge.
- This important activity is being proactively undertaken by Volkswagen in coordination with the United States Department of Transportation's National Highway Traffic Safety Administration (NHTSA). The results of this initiative will be shared with NHTSA. Volkswagen urges you to participate at your earliest convenience.
- **Time is of the essence.** Volkswagen needs to collect a certain number of airbags under this program, and once that number is reached this special parts collection program will end and no further airbag replacements will be made.
- Please contact an authorized Volkswagen dealer **in Florida only** at your earliest convenience in order to arrange an appointment to have the driver and passenger seat-mounted side airbags in your vehicle replaced at no charge to you. ***Dealers outside of Florida are not included in this special program and cannot do this work for you.***
- Once you bring your vehicle to a Florida-based Volkswagen dealer, the airbag replacement process should take about four (4) hours to complete. However, depending upon the dealer's work schedule, your dealer may require additional time to perform the airbag replacements.

If you should have any questions about this communication, please reach out to us using your preferred method of communication at www.vw.com/contact or by calling us at 800-893-5298.

Thank you for your help with this important safety and quality assurance initiative. We appreciate your Volkswagen ownership, your willingness to help, and apologize for any inconvenience this may cause you.

Sincerely,

Volkswagen Customer Protection

⚠ WARNING

DO NOT detonate the airbags prior to return. Airbags are to be returned in-tact and remain in their as-removed state.

! NOTE

Damages resulting from improper repair or failure to follow these work instructions are the dealer's responsibility and are not eligible for reimbursement under this action.

Required Parts

<u>Criteria</u>	<u>Quantity</u>	<u>Part Number</u>	<u>Part Description</u>
01	1	5N0 880 241 K	Driver Side Airbag
02	1	5N0 880 242 L	Passenger Side Airbag
All	1 per seat	N 907 912 01	Bolt for Air Bag
All	Up to 16 per seat	N 015 261 2	Upholstery Clamp
All	Up to 9 per vehicle	N 020 90 22	Cable Tie

Required Tools

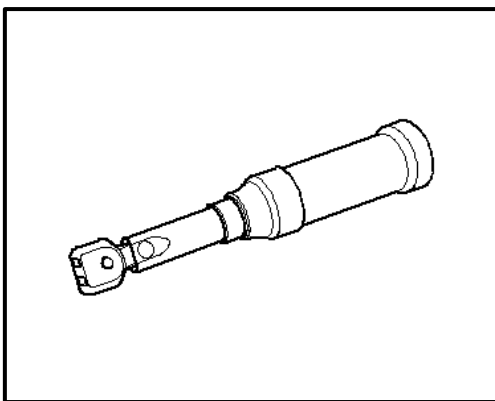

- VAG1783 - Torque wrench 2-10 Nm (or equivalent)

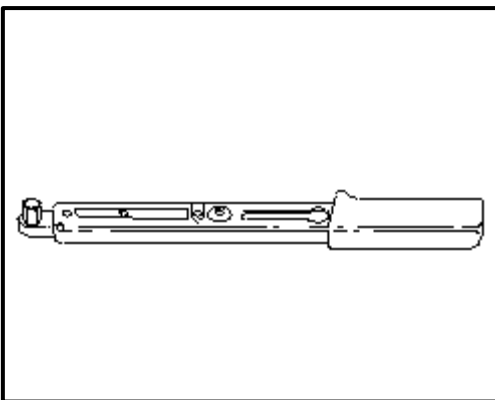

- VAG1331 - Torque Wrench 5-50 Nm (or equivalent)



- VAS6136 – Seat Repair Fixture



- VAS6095A – Engine and Gearbox Bracket



- VAS6281 – Airbag Lockout Adapter



- VAS6282 – Airbag Lockout Adapter

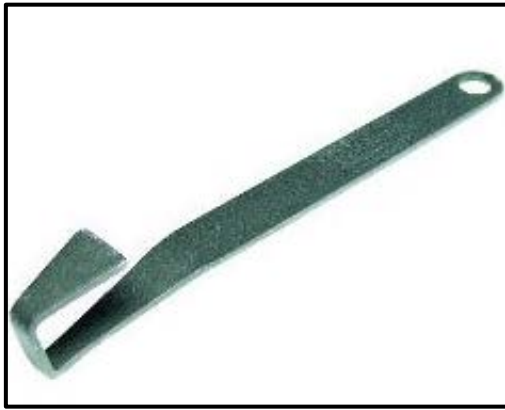

- 3399 – Assembly Tool (or equivalent)



- T10236-1 – Window Release Tool (or equivalent)

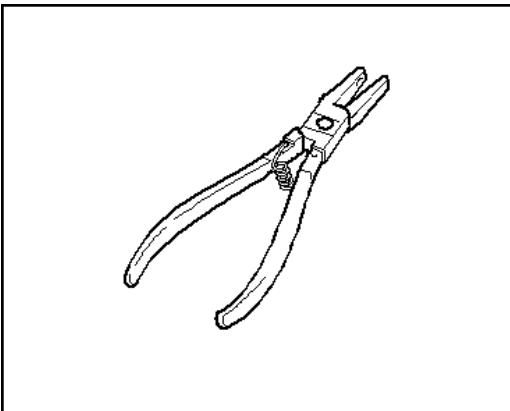

- VAG1634 - Upholstery Clip Pliers (or equivalent)



- VAS871 001 – Universal Vehicle Protector (or equivalent)

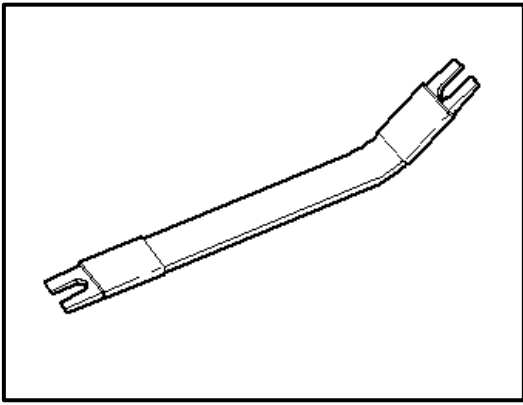

- 80-200 – Pry Lever



- P/N 1S0 881 451 - Slide

Section A – Seat Removal and Disassembly

WARNING

Risk of injury. Refer to “Warning and Safety Precautions”, found in **Appendix A** at the end of this document.

NOTE

Due to variations in vehicle equipment and options, the steps/illustrations in this work procedure may not identically match all affected vehicles.

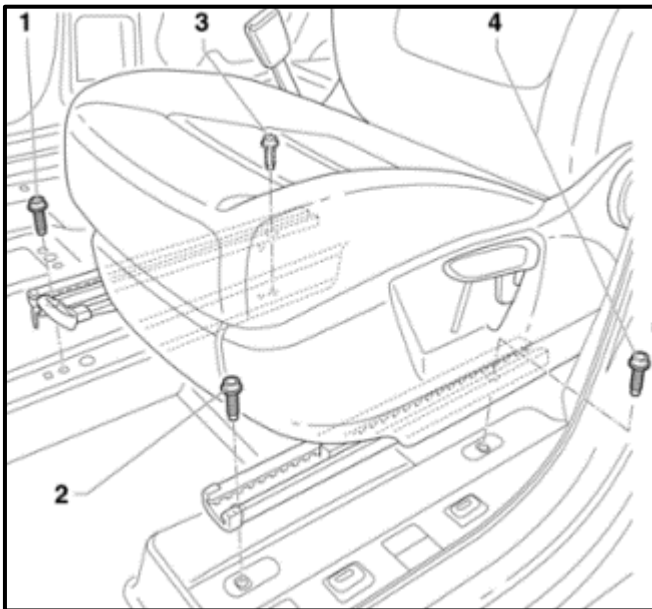

- Position the seat as far forward as possible using the forward/back adjustment.
- Remove the bolts <3 and 4>.
- Position the seat as far back as possible using the seat forward/back adjustment.
- Remove the bolts <1 and 2>.

NOTE

If removing both power front seats, remove bolts <1, 2, 3, and 4> from both seats prior to disconnecting the battery.

- Switch the ignition on.
- Open the hood.
- Open the battery cover.
- Disconnect and isolate the negative battery cable.

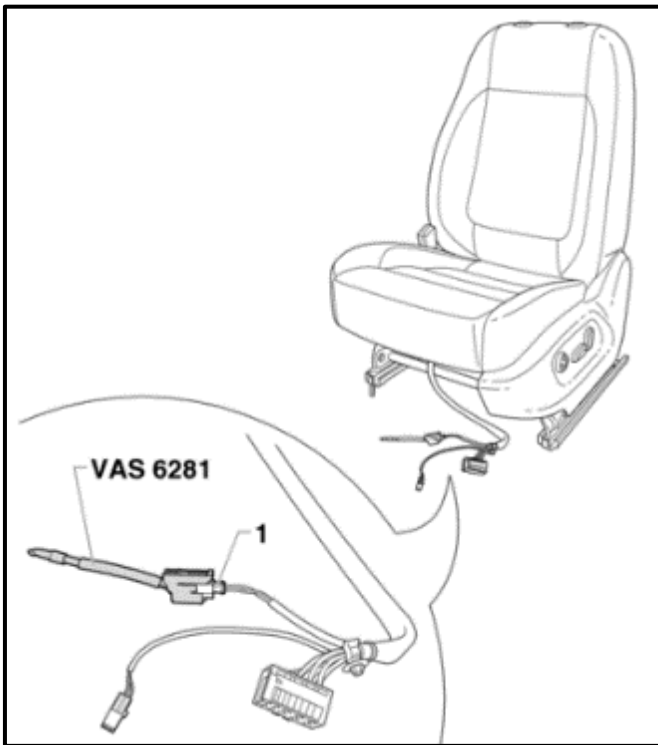

- Remove the seat wiring harness from the floor mount.
- Disconnect the seat and airbag wiring harness connectors from the connector station in the carpet.
- Connect the Airbag Lockout Adapter VAS6281 to the airbag wiring harness as shown <1>.

NOTE

If the Airbag Lockout Adapter VAS6281 does not fit, use the Airbag Lockout Adapter VAS6282.

CAUTION

The Airbag Lockout Adapter VAS6281 or VAS6282 **MUST** stay connected to the seat wiring harness until the seat is reinstalled in the vehicle.

NOTE

- Due to the weight and size of the front seat, assistance from a second technician may be helpful in removing the seat.
- While lifting the seat out of the vehicle, it must not be grasped by the attachments (i.e. seat belt latch, seat adjustment lever(s), seat trim panels, etc.). Damage to these components is **NOT** covered under this action.



- To protect the sill panel before removing the front seat, install the Universal Vehicle Protector VAS871 001 <as shown>.
- Carefully remove the seat from the vehicle through the door opening.



- Mount the Engine/Transmission Holder – Seat Repair Fixture VAS6136 on the Engine and Gearbox Bracket VAS6095A.
- Secure the seat to the Engine/Transmission Holder – Seat Repair Fixture VAS6136.

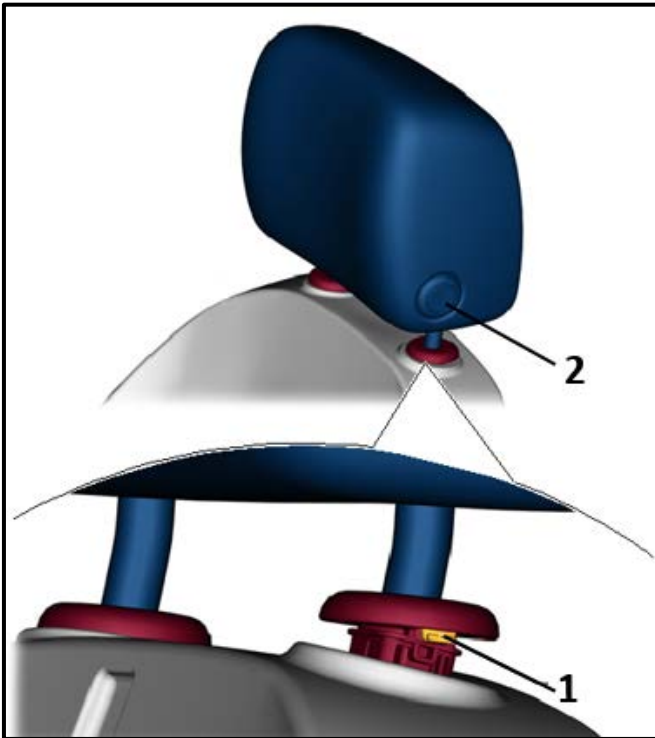

- Lift the headrest to its fully-raised position.
- Using a small screwdriver (or equivalent) press and hold the release button <1> on the RIGHT SIDE headrest post.
- Press and hold the release button <2> on the LEFT SIDE of the headrest itself.
- Remove the headrest from the seat.

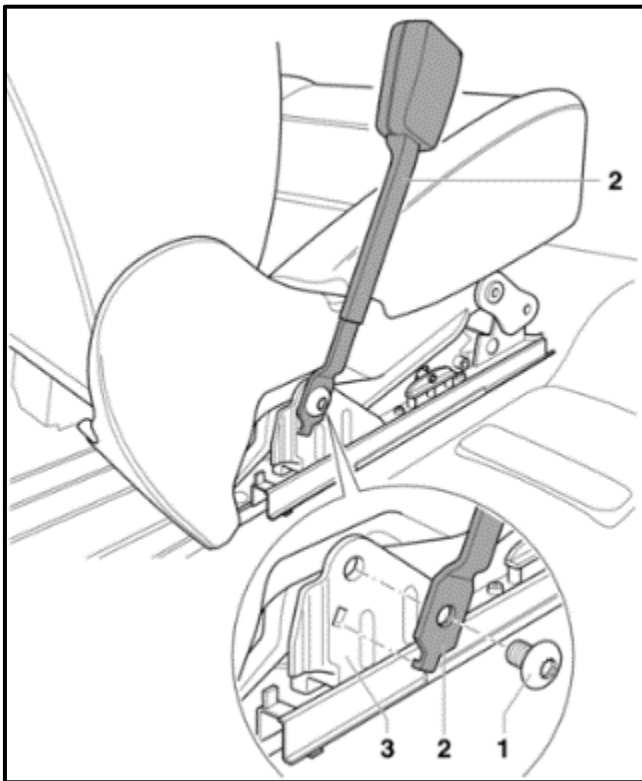

- Remove the mounting bolt <1>.
- Remove the seat belt latch <2> from the mount in the seat frame <3>.

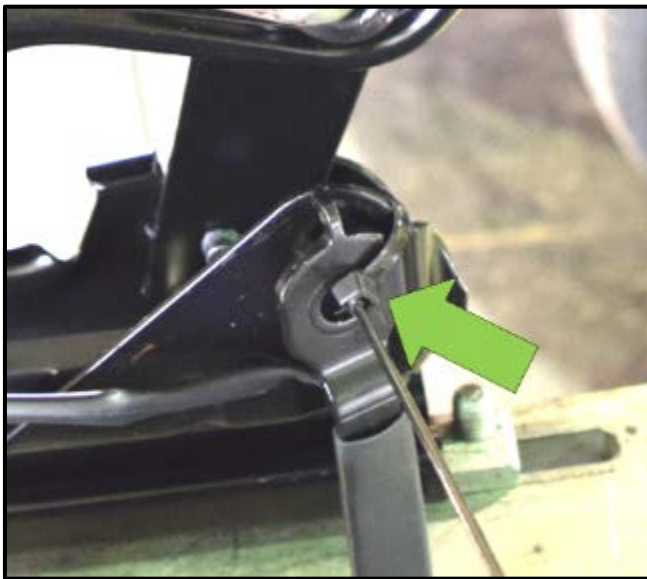

- Secure the seat belt latch to the seat frame using a tie wrap or elastic cord as shown <arrow>.

Part Number	Part Description
N 020 90 22	Cable Tie

! NOTE

During seat disassembly, DO NOT allow the seat belt latch to hang freely by the wiring harness. Failure to do so may result in damage to the wiring harness, which is NOT covered under this action.

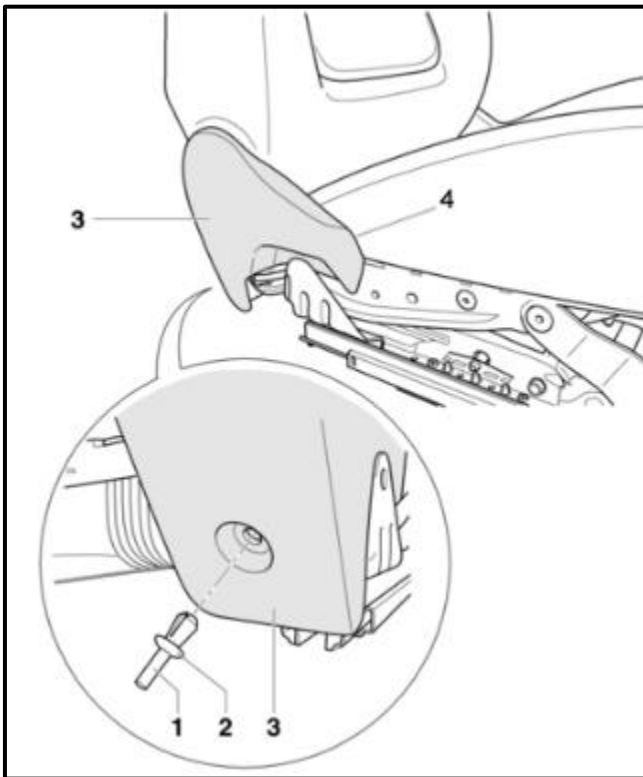

- Using a small screwdriver (or equivalent) press the clamping pin <1> inward and remove it from the expanding clip <2>.
- Remove the expanding clip <2>.
- Release the clip <4> retaining the trim <3> to the seat frame.

! NOTE

Use care when removing trim panels. Damage to these components is NOT covered under this action.

- Remove the trim <3> from the seat frame.

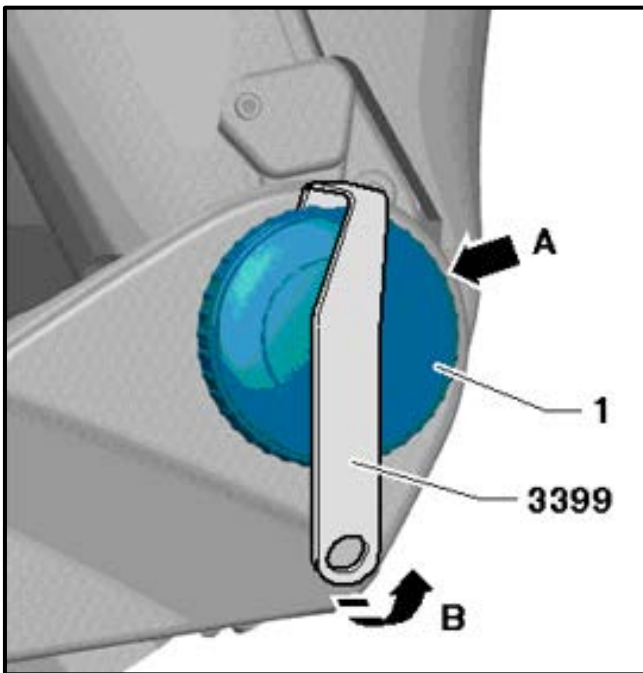

- If equipped, turn the seat back adjustment wheel <1> until a retainer is visible from behind <arrow A>. Use a flashlight if necessary.
- Using the Assembly Tool 3399, carefully pry the adjustment wheel off the seat <direction of arrow B>.
- Turn the seat back adjustment wheel 120° further and repeat the process until the wheel is able to be removed.
- Remove the seat back adjustment wheel.

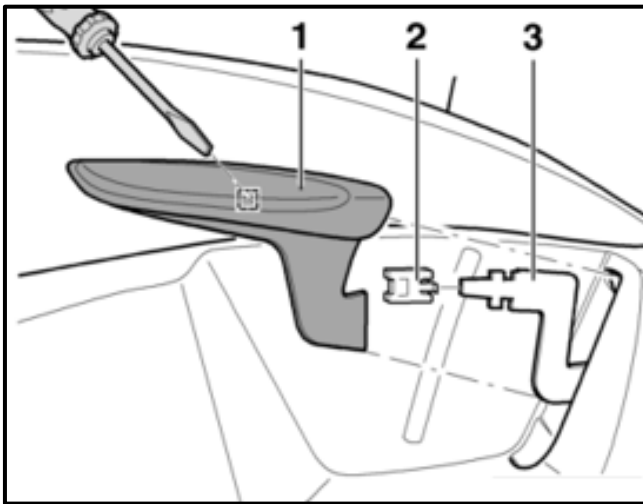

- If equipped, pull the height adjustment handle <1> upward.
- Using a small screwdriver (or equivalent), release the metal tab on the clamp <2> located on the inside of the height adjustment handle.
- Remove the adjustment handle <1> from the adjusting lever <3>.

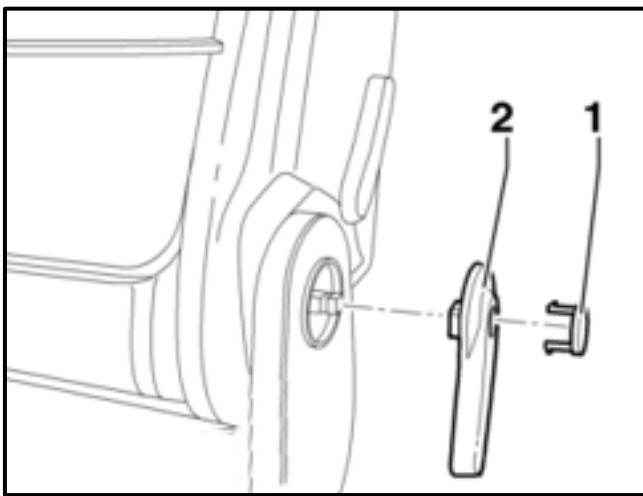

- If equipped, remove the release lever cap <1> and remove the release lever <2>.

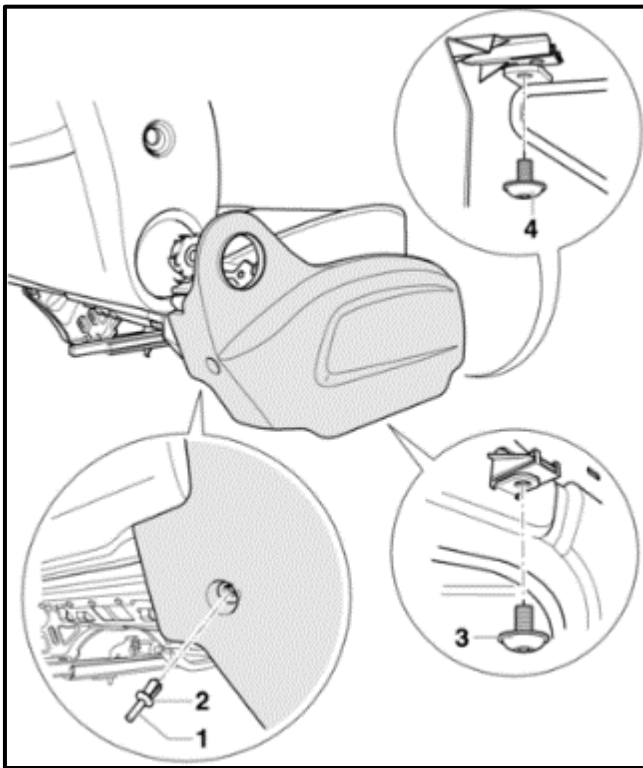

- If removing the passenger seat, remove the sill side trim panel as shown.
- Using a small screwdriver (or equivalent) press the clamping pin <1> inward and remove the expanding clip <2>.
- Remove the screws <3 and 4>.

! NOTE

Use care when removing trim panels. Damage to these components is NOT covered under this action.

- Remove the trim panel from the seat.

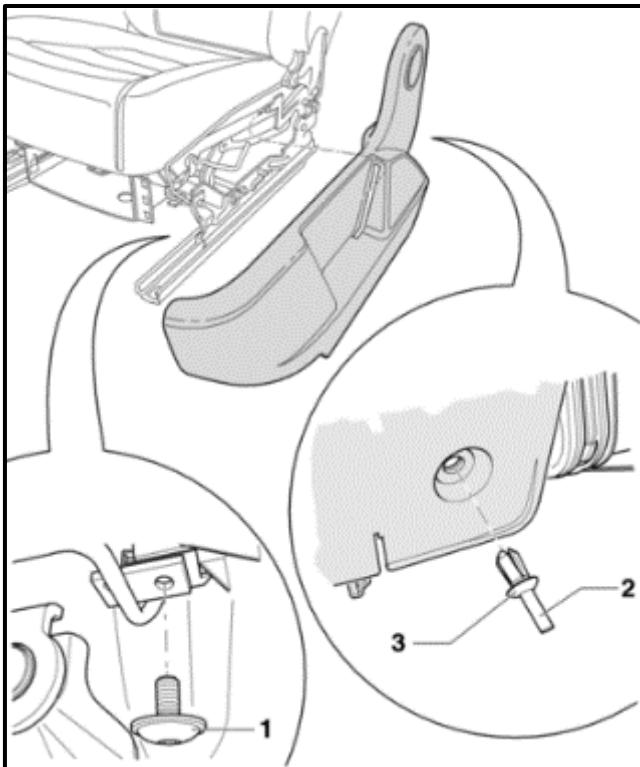

- If removing the driver seat, remove the sill side trim panel as shown.
- Remove the screw <1>.
- Using a small screwdriver (or equivalent) press the clamping pin <2> inward and remove it from the expanding clip <3>.
- Remove the expanding clip <3>.
- Disconnect any electrical connectors between the trim panel and the seat.

! NOTE

Use care when removing trim panels. Damage to these components is NOT covered under this action.

- Remove the trim from the seat frame.

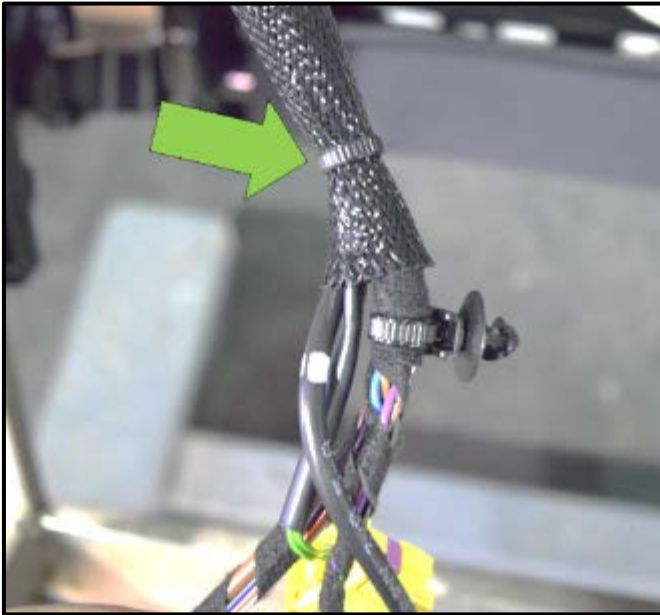

i TIP

To aid in proper reassembly, wiring harness routing and orientation should be noted prior to disassembly. Take pictures and record the location of the wiring harnesses before removal.

- Carefully cut the tie wrap from the lower end of the seat wiring harness sheath <arrow>.

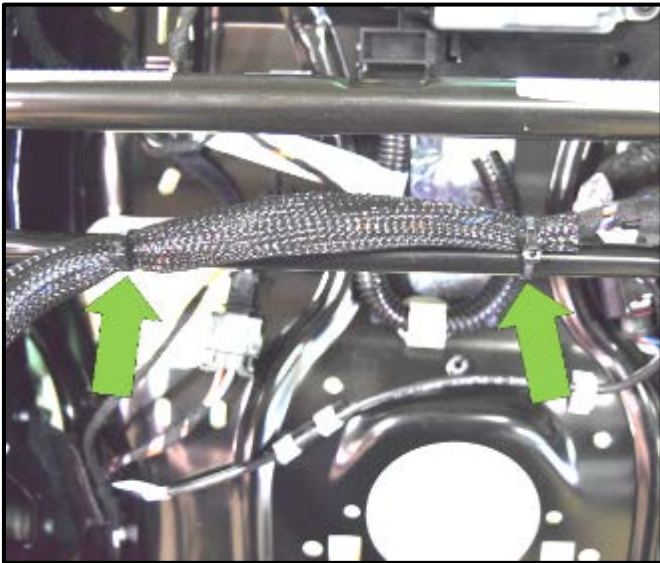

- Carefully cut the two tie wraps from the seat frame and wiring harness sheath <arrows>.

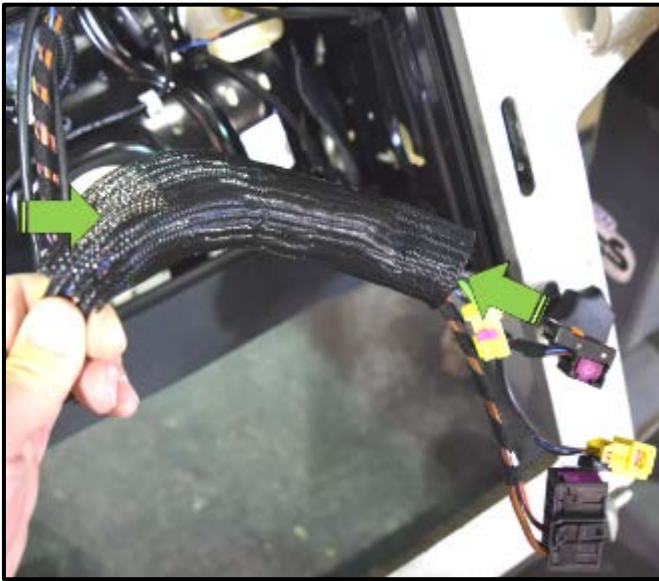

- Compress the seat wiring harness sheath together to expand it <direction of arrows>.
- Remove the airbag wiring harness and connector from the seat wiring harness sheath.

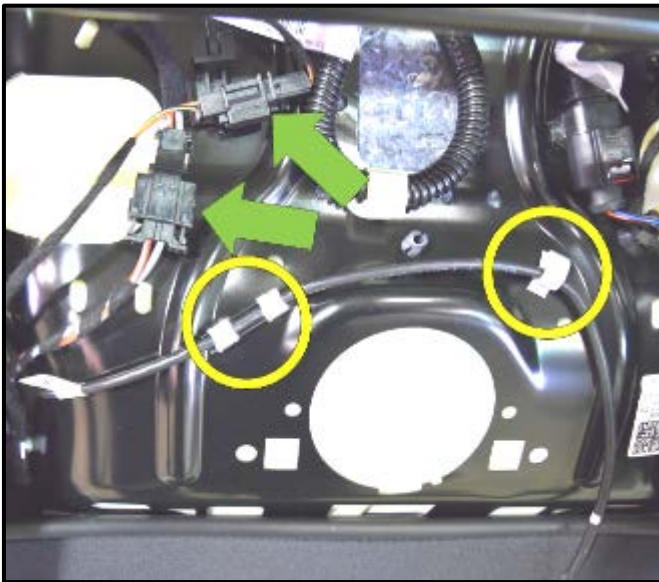

- Disconnect the airbag wiring harness retainers <circles> from the seat bottom pan.
- Disconnect any electrical connectors <arrows> between the seat bottom and the seatback.

NOTE

The number of electrical connectors between the seat bottom and the seatback may vary based on vehicle equipment.

If removing a forward folding seat, proceed to Section B. If removing a non-forward folding seat, proceed to Section C:

Section B – Forward Folding Seatback Removal

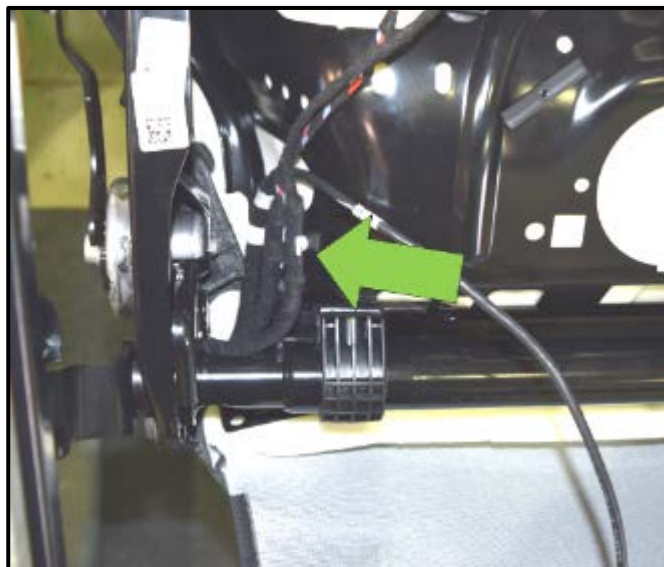

- Release any remaining wiring harness retainers located in the area near the seatback hinge <arrow>.



- Carefully remove the seat and airbag wiring harnesses from the seatback frame.

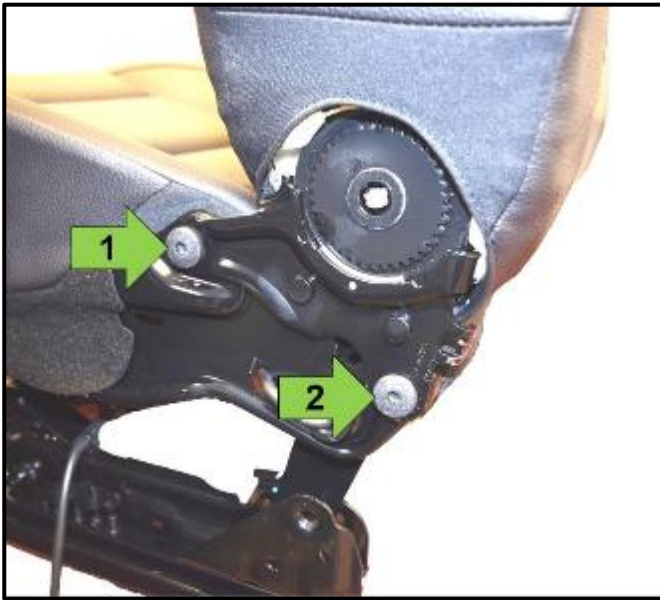

- Loosen, but do not remove, the front mounting bolt <arrow 1> on both seatback hinges.
- Remove the rear mounting bolt <arrow 2> from both seatback hinges.
- Tilt the seatback forward and rest it against the seat bottom.

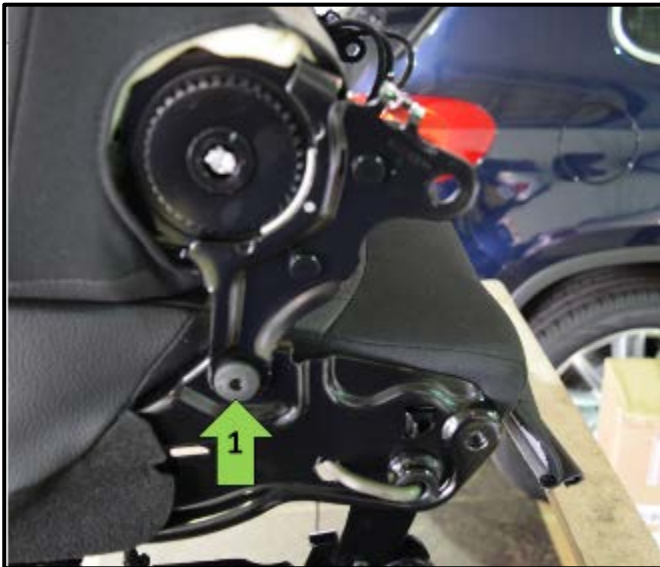

- Remove the front mounting bolt <arrow 1> from both seatback hinges.
- Remove the seatback from the seat bottom and place it on a clean, dry working surface.

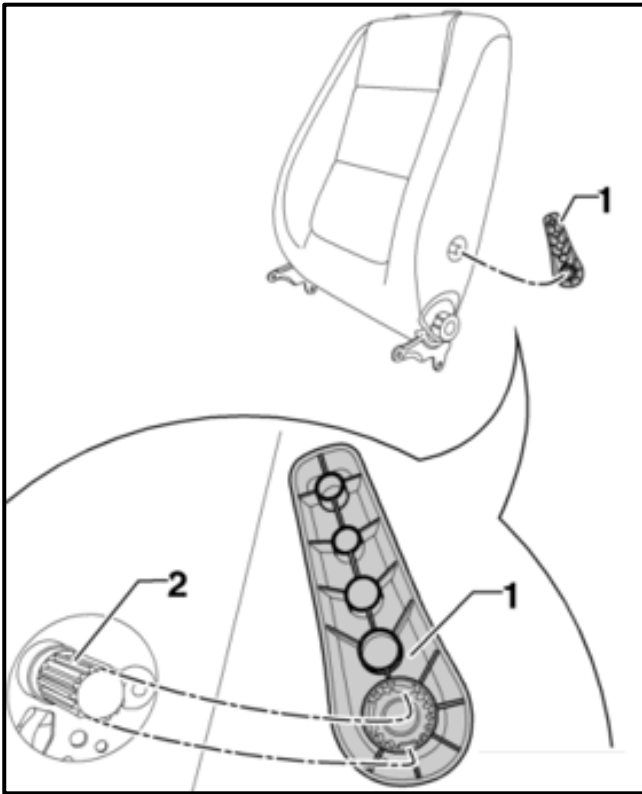

- If equipped, pull outward on the lumbar adjustment lever <1> and remove it from the shaft <2>.

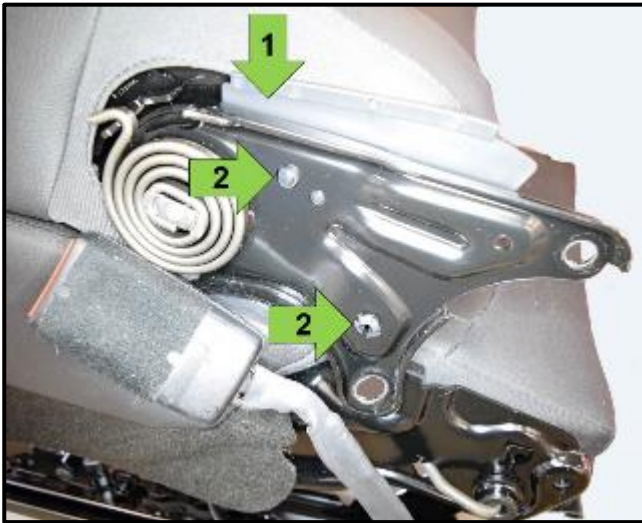

- Remove the seatback trim plates <arrow 1> on both sides of the seat by releasing the retainers <arrow 2> then using a Pry Lever 80-200 (or equivalent) to remove the trim plate.



- Using a small screwdriver (or equivalent) extract the end of the seatback zipper on both sides of the seat <arrow>.



- Once the ends of the seatback zipper have been extracted, carefully separate the zipper by pulling both halves in the directions shown <arrows>.



- Continue to separate the zipper until the halves are completely separated <as shown>.

Proceed to Section E

Section C – Non-Forward Folding Seatback Removal

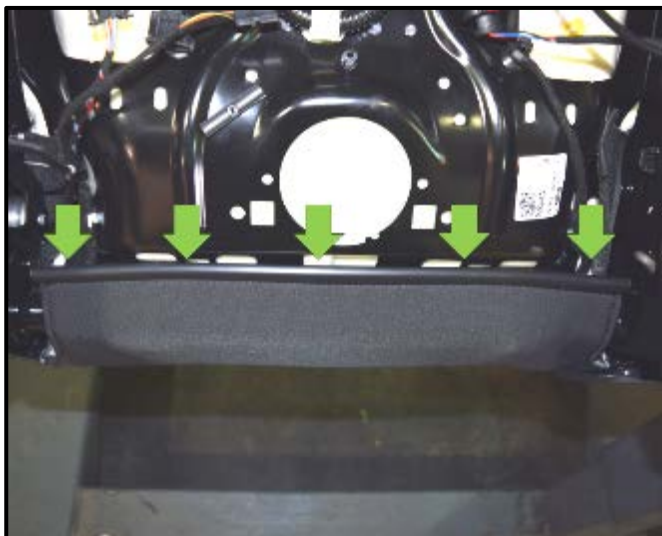

- Release the lower seat cover channel from the seat bottom pan <arrows>.

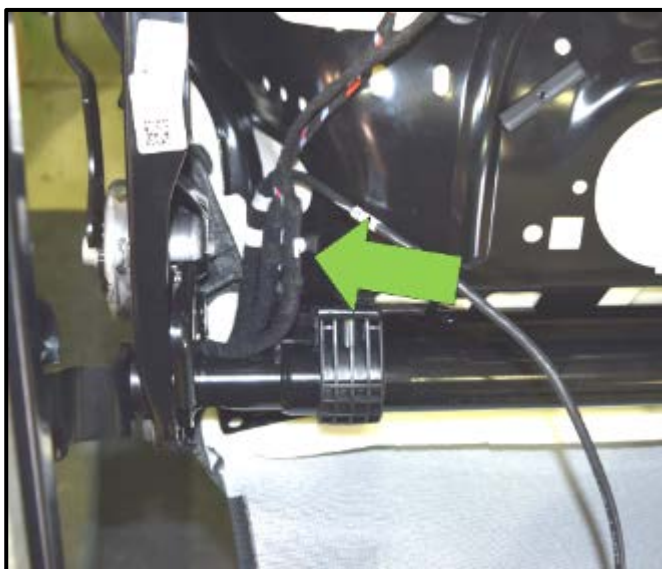

- Release any remaining wiring harness retainers located in the area near the seatback hinge <arrow>.

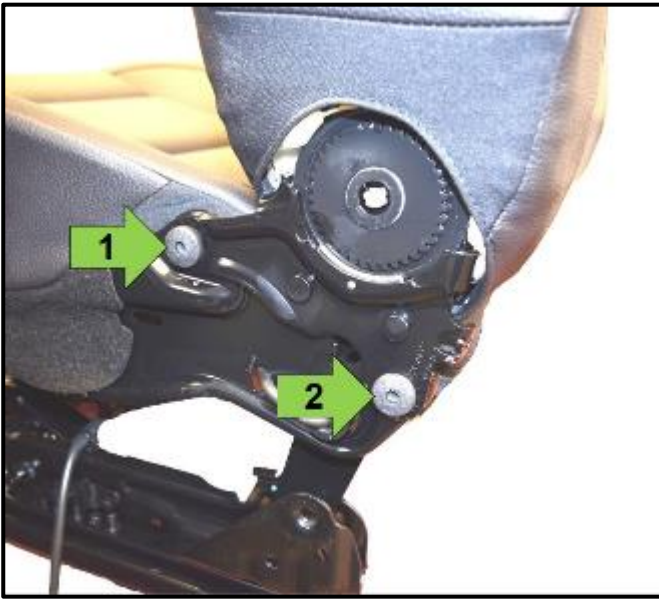

- Loosen, but do not remove, the front mounting bolt <arrow 1> on both seatback hinges.
- Remove the rear mounting bolt <arrow 2> from both seatback hinges.
- Tilt the seatback forward and rest it against the seat bottom.



- Carefully remove the seat and airbag wiring harnesses from the seat bottom <arrow>.

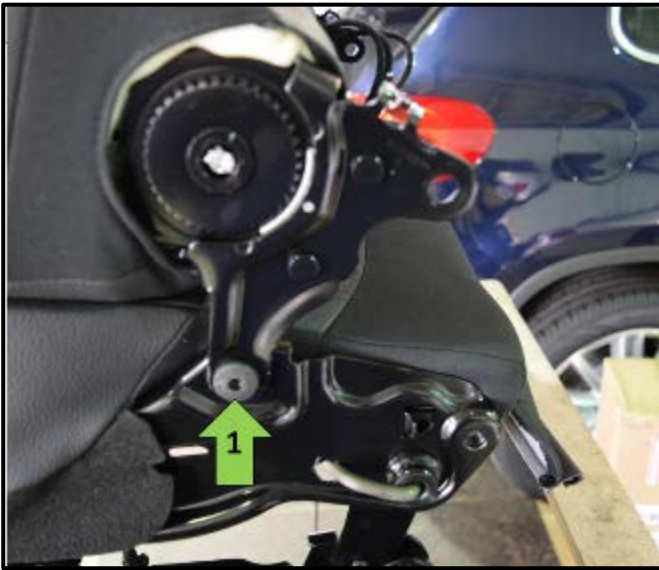

- Remove the front mounting bolt <arrow 1> from both seatback hinges.
- Remove the seatback from the seat bottom and place it on a clean, dry working surface.

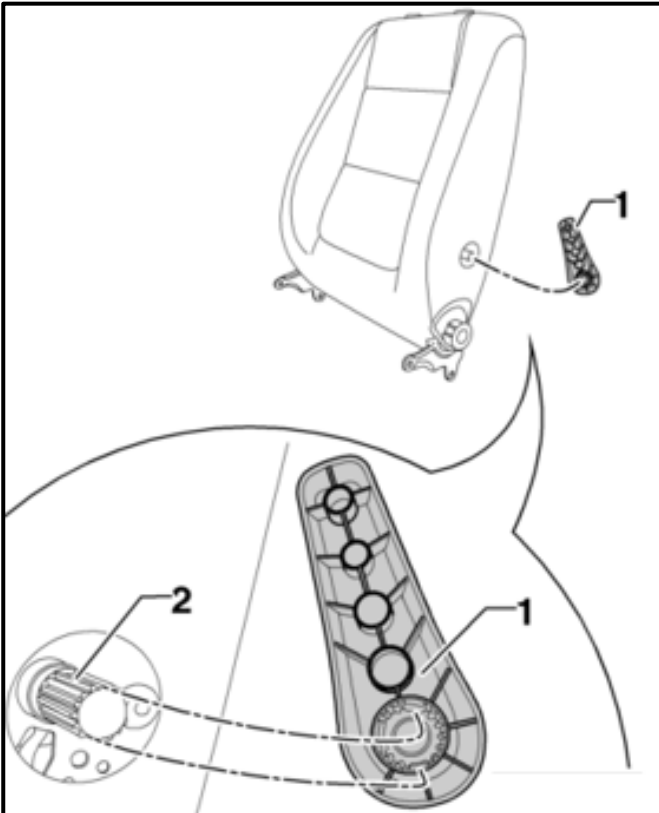

- If equipped, pull outward on the lumbar adjustment lever <1> and remove it from the shaft <2>.

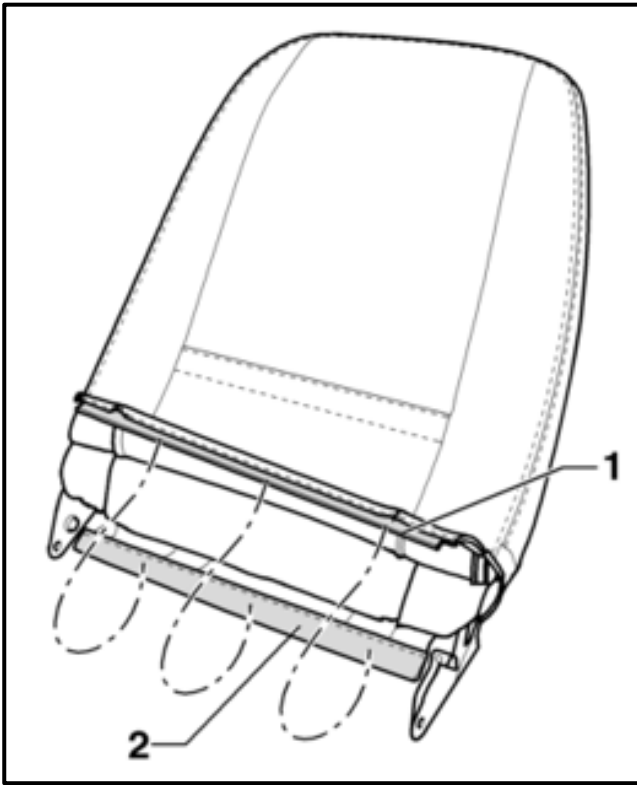

- Release the contact surface <1> from the mount <2> on the back side of the seatback.

Proceed to Section D

Section D – Side Airbag Replacement

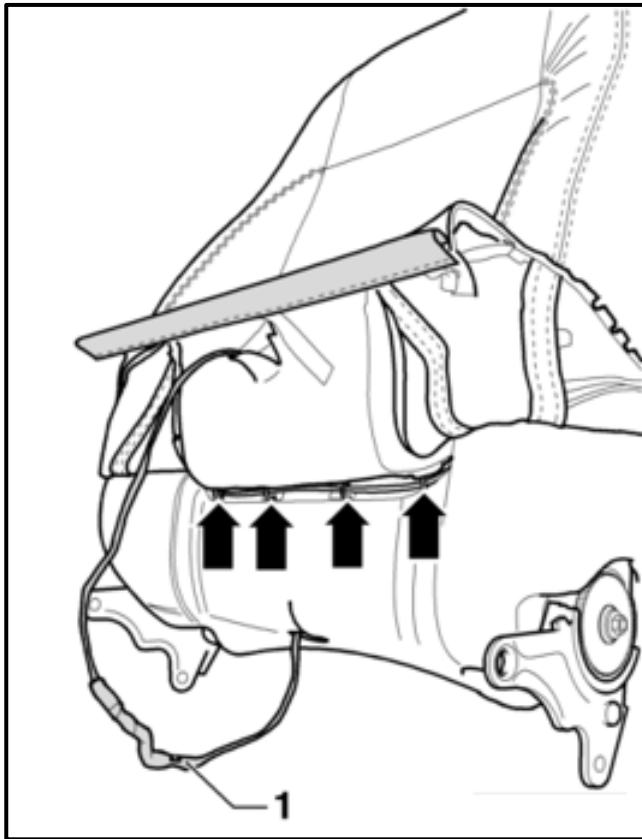

- Roll the cover upward on the front side of the seatback.
- If equipped, guide the heated seat wiring harness <1> through the opening in the seat cushion.

! NOTE

If equipped with heated seats, be careful not to damage the seat heater element when cutting the upholstery clips. Damage to these components is NOT covered under this action.

- Using appropriate side-cutting pliers, cut the upholstery clips <arrows>.

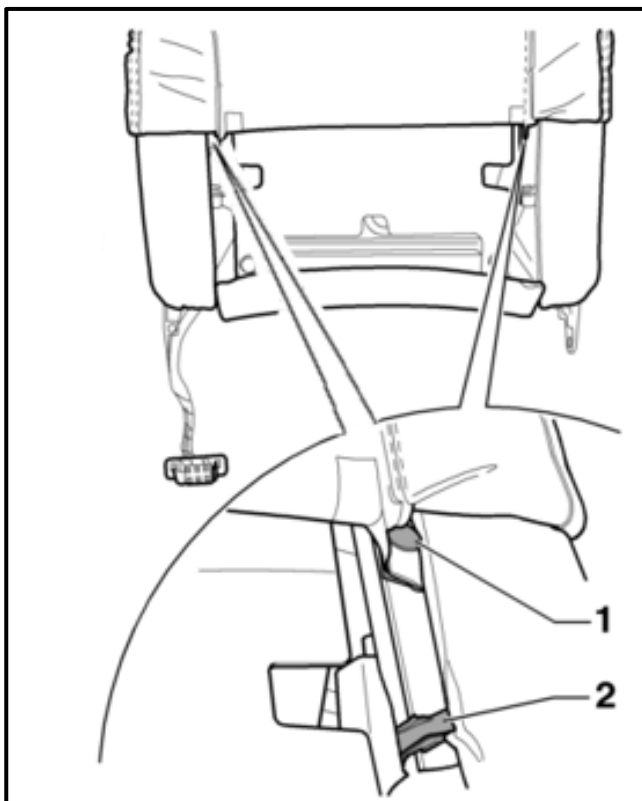

- Using Window Release Tool T10236-1 (or equivalent), remove the clip <1> from each side of the backrest frame.
- Release the mounting strap <2> from each side of the backrest frame.



- Fold the cover up and cut the upholstery clips <arrows>.

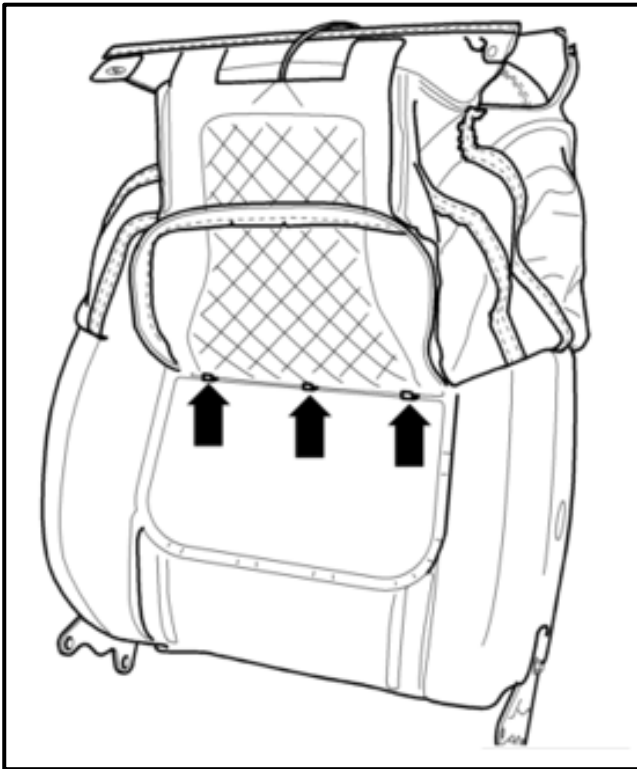

- Fold the cover up and pry the cover profile out of the cushion mounts <arrows> using a small screwdriver (or equivalent).



- Fold the cover up and cut the upholstery clips <arrows>.

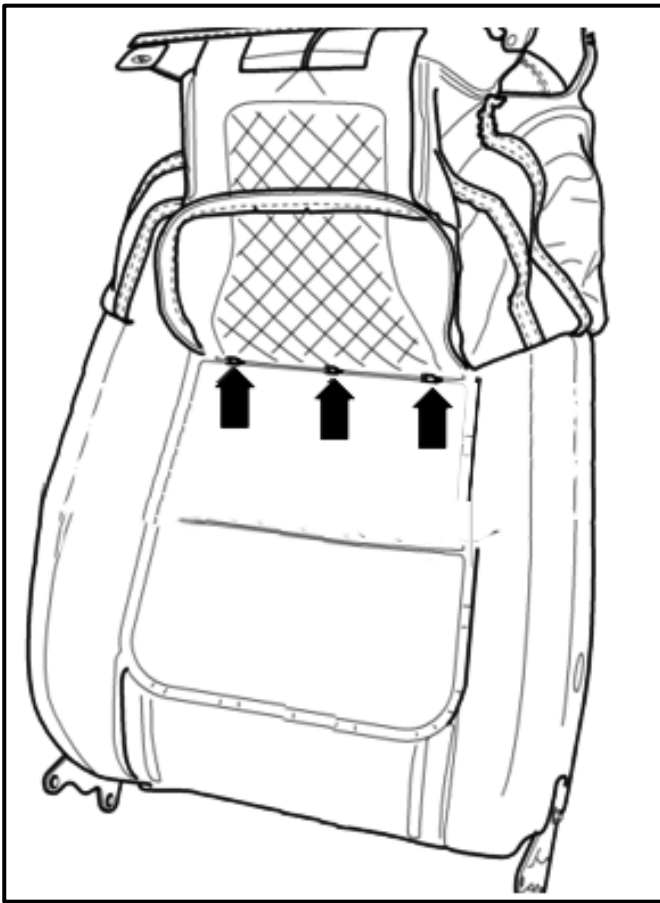

- Fold the cover up and pry the cover profile out of the cushion mounts <arrows> using a small screwdriver (or equivalent).

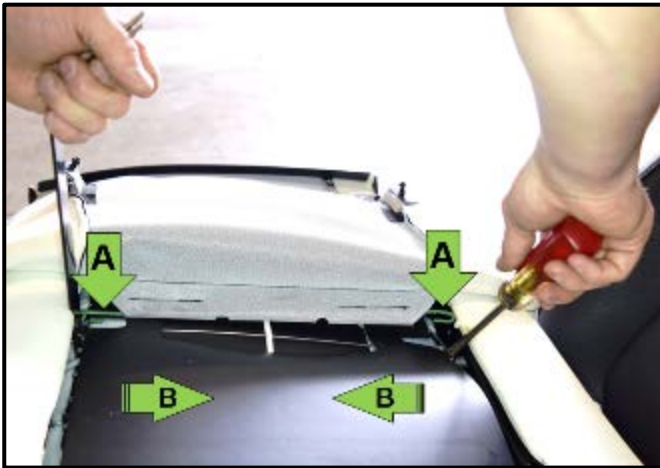

- Fold the cover up and remove the rear cover mount rod <arrow A> by using a pair of Pry Levers 80-200 (or equivalent) to gently compress the lumbar adjustment frame in the direction shown <arrow B>.

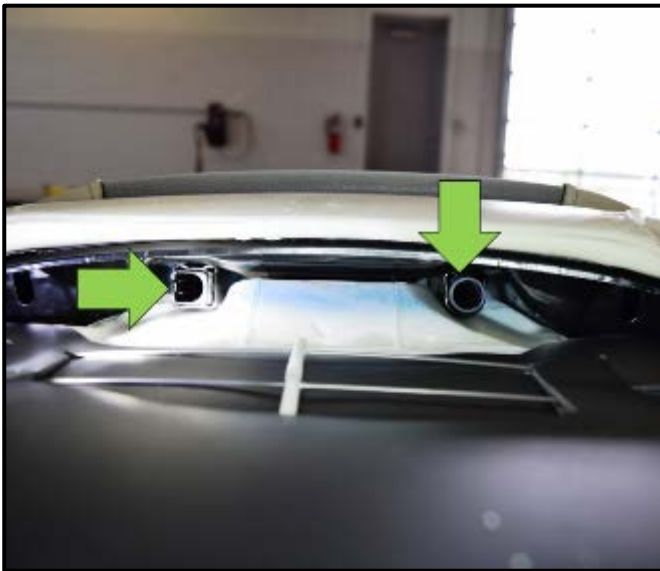

- Release the retainers <arrows> securing the headrest guides to the seat frame and push the guides towards the top of the seat to remove them.



- Fold the cover up and cut through the remaining upholstery clips <arrows> on both sides of the seat.
- Remove the cover from the seat frame.

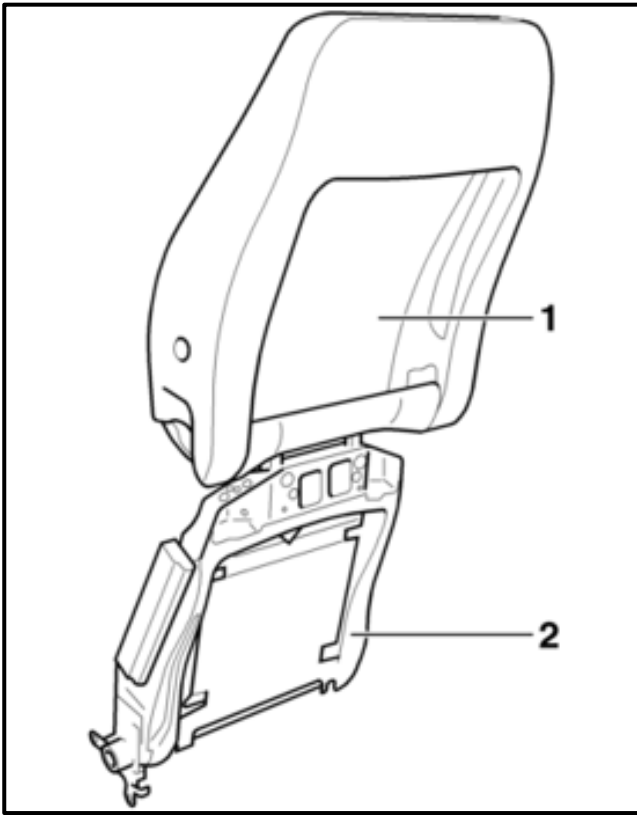

- Pull the cushion <1> up and remove it from the backrest frame <2>.

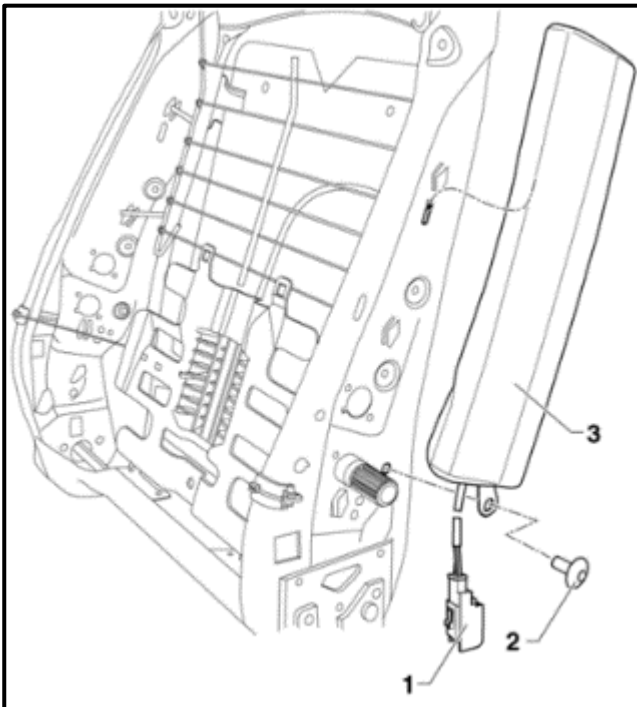

- Remove the airbag wiring harness <1> from the backrest frame.
- Remove and discard the bolt <2>.

! NOTE

DO NOT discard or detonate the airbag after removal. Airbags are to be returned undetonated, as instructed in the Parts Return section at the end of this procedure.

- Remove the side airbag <3> from the mount in the backrest frame.

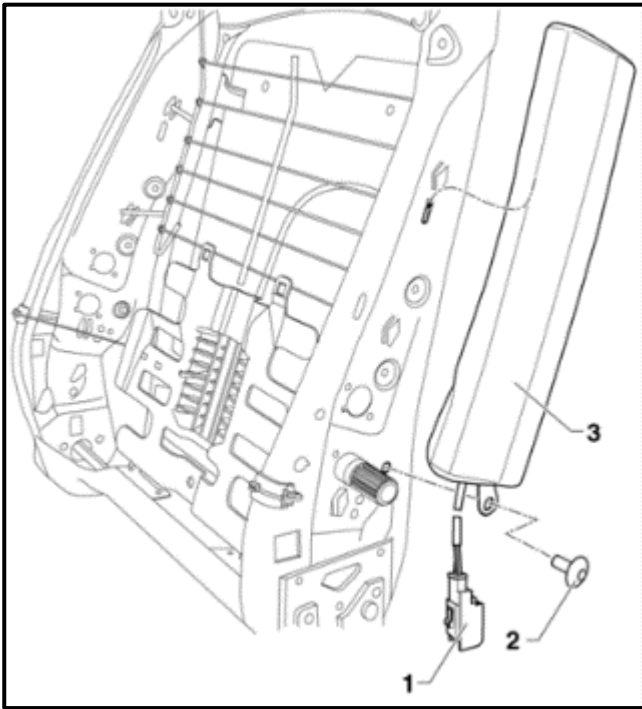

- Install the replacement side airbag <3> to the mount in the backrest frame.

Part Number	Part Description
5N0 880 241 K	Driver Side Airbag
5N0 880 242 L	Passenger Side Airbag

- Install the NEW bolt <2> and torque to 9 Nm using torque wrench - VAG1783 (or equivalent).

Part Number	Part Description
N 907 912 01	Bolt for Air Bag

- Properly route and secure the airbag wiring harness <1> to the backrest frame.

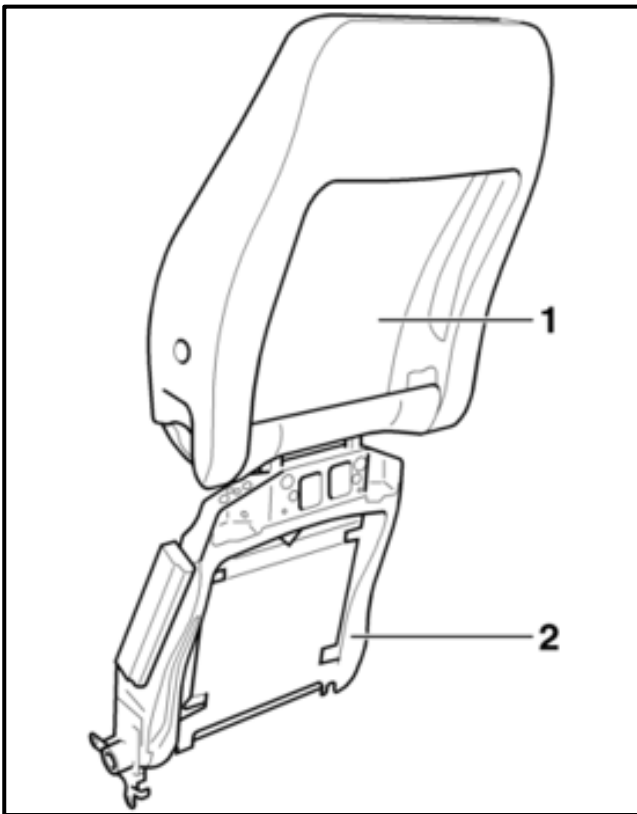

NOTE

Ensure all the cut upholstery clips are removed from the seat cover and seat cushion before reinstalling. Failure to do so may cause damage to the seat cover.

- Slide the cushion <1> down onto the backrest frame <2>.

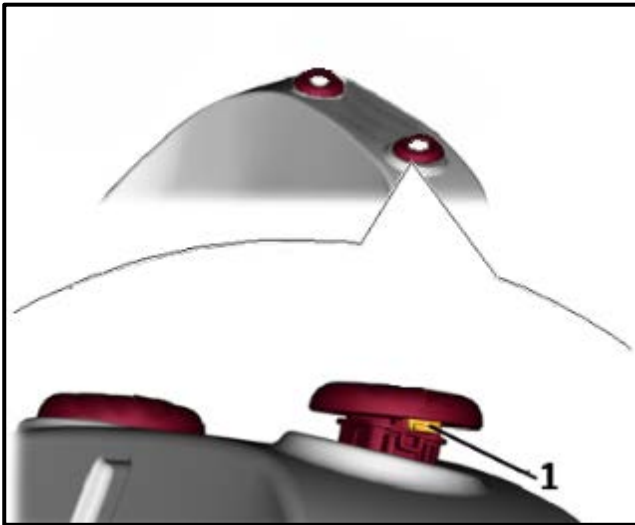

- Realign the seat cover to the seatback frame and reinstall the headrest guides, ensuring that the release buttons <1> are fully seated.



- Install new upholstery clamps <arrows> on both sides of the seat using Upholstery Clip Pliers - VAG1634 (or equivalent).

Part Number	Part Description
N 015 261 2	Upholstery Clamp

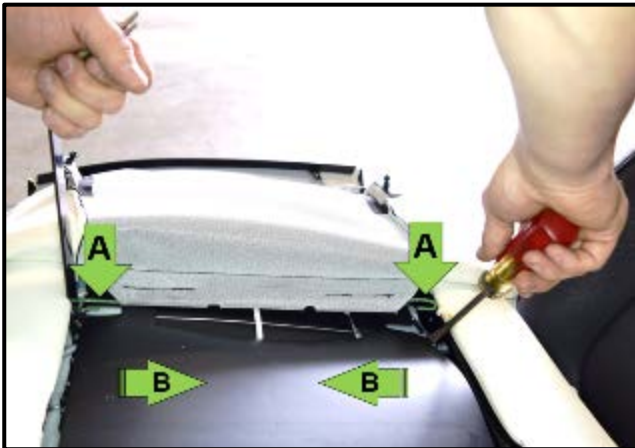

- Fold the cover down and install the rear cover mount rod <arrow A> by using a pair of Pry Levers 80-200 (or equivalent) to gently compress the lumbar adjustment frame in the direction shown <arrow B>.

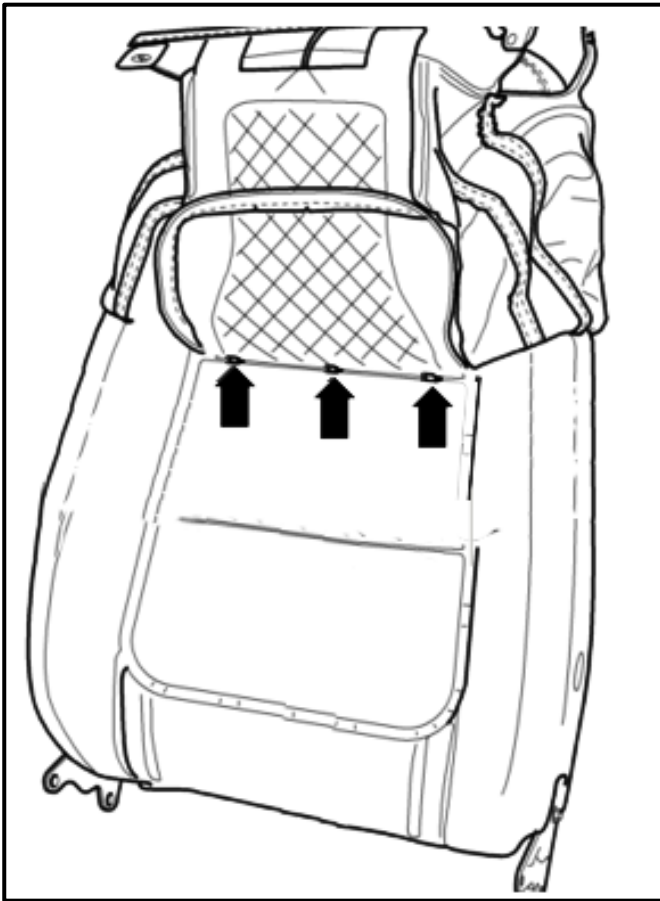

- Fold the cover down and reattach the cover to the cushion mounts <arrows>.



- Fold the cover down and install the new upholstery clamps <arrows> using Upholstery Clip Pliers - VAG1634 (or equivalent).

Part Number	Part Description
N 015 261 2	Upholstery Clamp

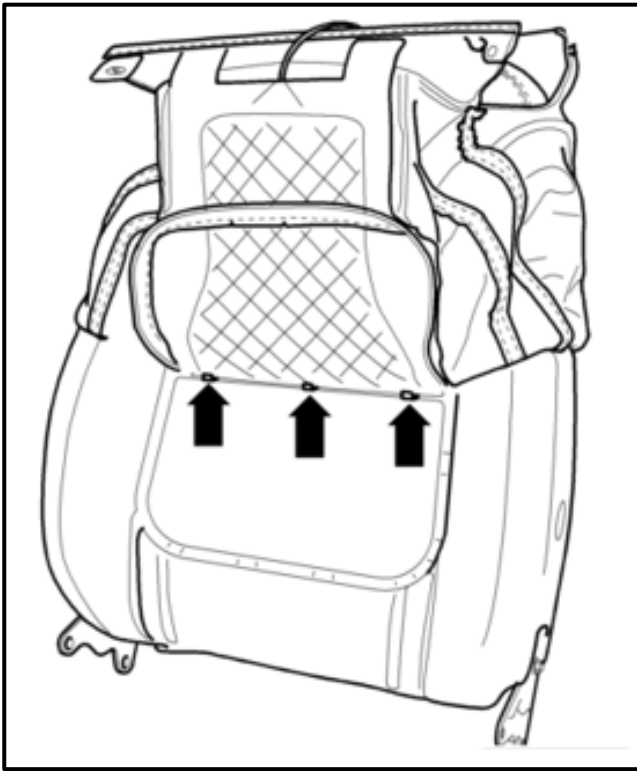

- Fold the cover down and reattach the cover to the cushion mounts <arrows>.



- Fold the cover down and install the new upholstery clamps <arrows> using Upholstery Clip Pliers - VAG1634 (or equivalent).

Part Number	Part Description
N 015 261 2	Upholstery Clamp

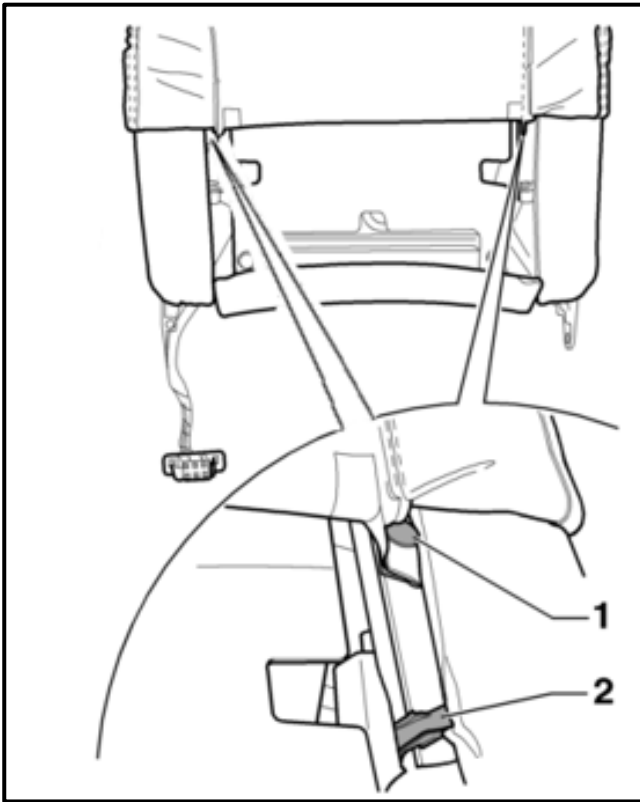

- Reinstall the clip <1> to each side of the backrest frame.
- Fold the cover down and secure the mounting strap <2> to each side of the backrest frame.

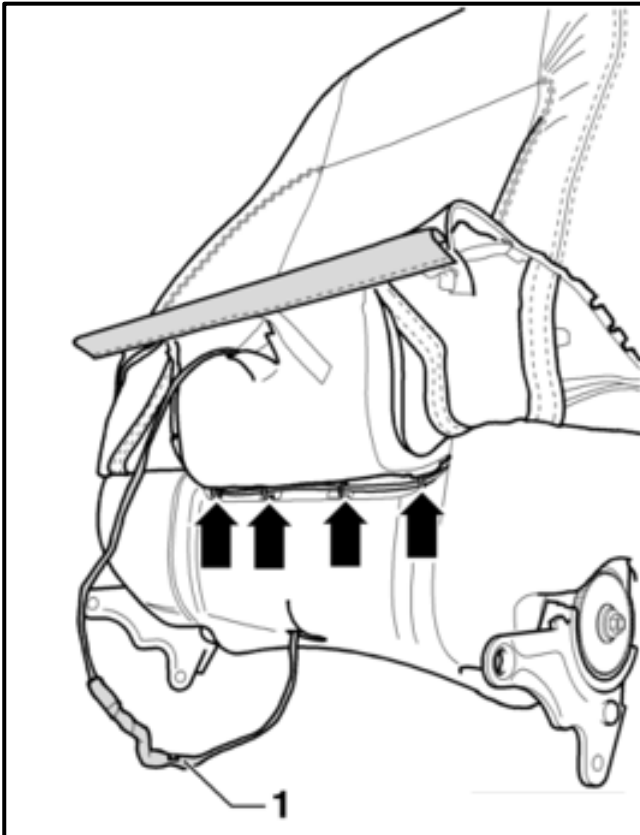

- Fold the cover further down and install the new upholstery clamps <arrows> using Upholstery Clip Pliers - VAG1634 (or equivalent).

Part Number	Part Description
N 015 261 2	Upholstery Clamp

- If equipped, guide the heated seat wiring harness <1> through the opening in the seat cushion.
- Roll the cover downward towards the rear of the seat.

If reinstalling a forward folding seat, proceed to Section E. If removing a non-forward folding seat, proceed to Section F:

Section E – Forward Folding Seatback Installation



- Roll the cover downwards and fold over the seatback bottom <as shown>.

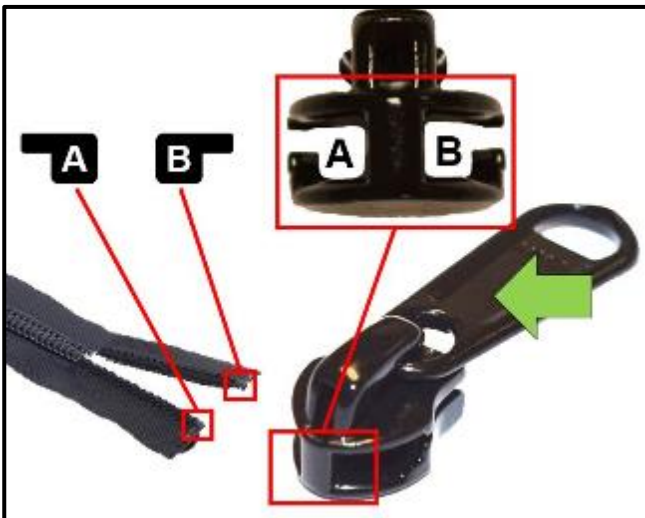

! NOTE

Note the orientation <A&B> of the seatback cover zipper to the slide <arrow> - P/N 1S0881451 prior to using the slide to ensure you are installing the slide properly. Failure to do so may damage the zipper and the slide.



- Install the slide <arrow> - P/N 1S0881451 to the seatback cover zipper.



- Using the slide, zip the seatback cover completely until the slide detaches itself from the other end of the zipper.



- Once zipping the seatback cover has been completed, tuck the end of the zipper into the seat <as shown>.

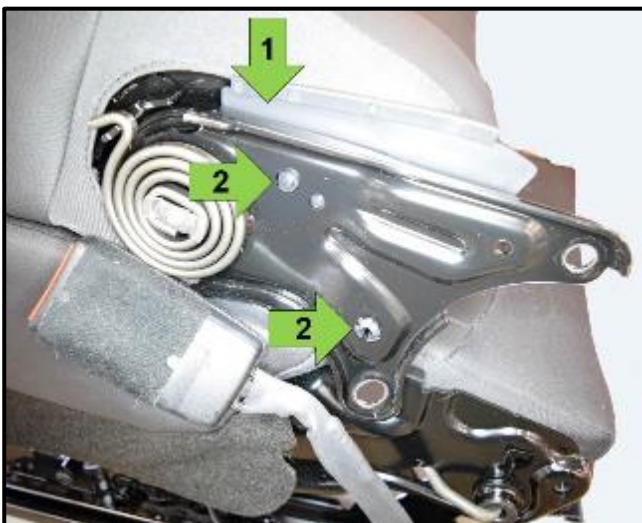

- Reinstall the seatback trim plate <arrow 1> to both sides of the seat and ensure that the retainers <arrow 2> are seated properly.

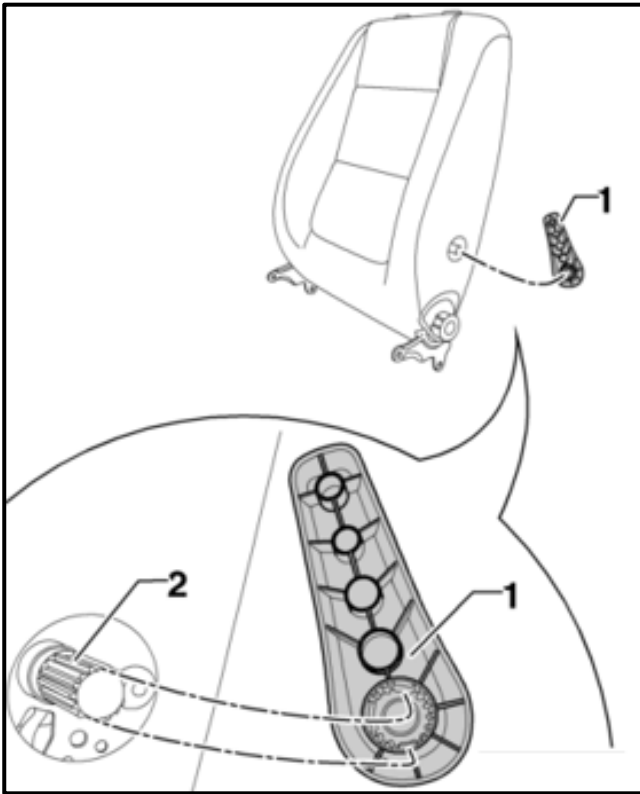

- If equipped, reinstall the lumbar adjustment lever <1> onto the shaft <2>, ensuring the splines in the lumbar adjustment lever align with the splines on the shaft.



- Align the seatback to the seat bottom, tilting the seatback forward and resting it against the seat bottom as shown.
- Reinstall the front mounting bolts <arrow 1> to both seatback hinges, but do not tighten.

 TIP
<p>To aid in proper reassembly, reference the wiring harness routing and orientation noted prior to disassembly.</p>

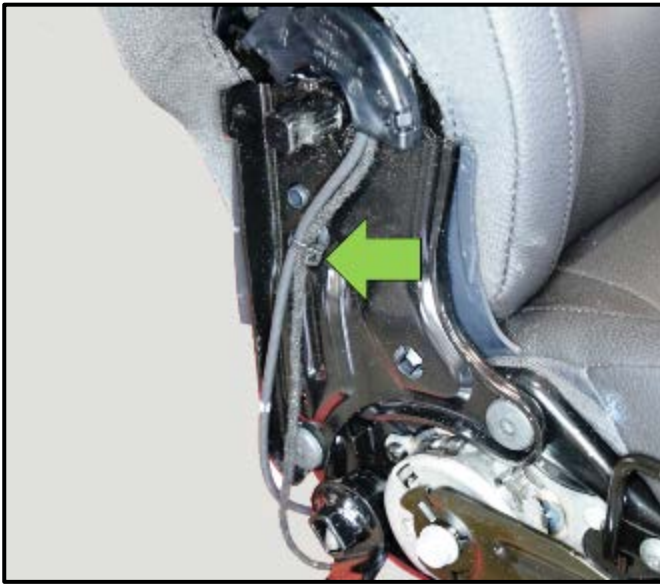

- Install the seat wiring harness as shown.
- Properly align the seat and airbag wiring harnesses to the seatback frame.
- Secure the seat and airbag wiring harnesses to the seatback frame using a tie-wrap <arrow>.

Part Number	Part Description
N 020 90 22	Cable Tie

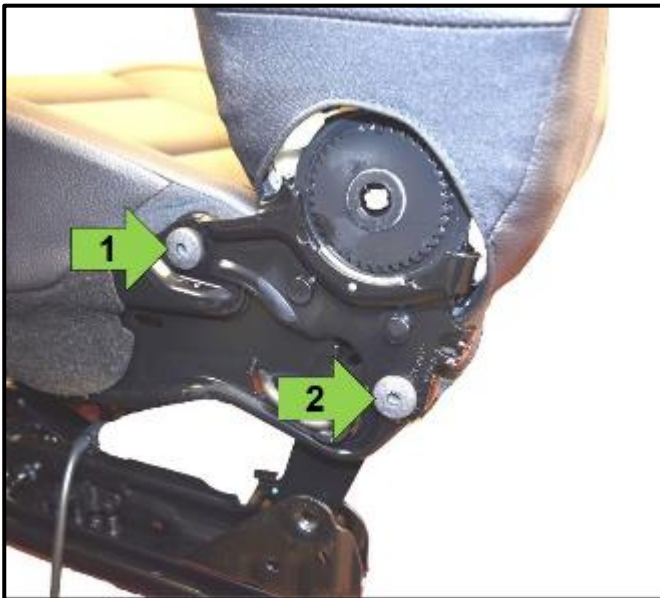

- Tilt the seatback rearward and reinstall the rear mounting bolt into position <arrow 2> on both seatback hinges.
- Torque both bolts <arrows 1 & 2> on both sides to 34.5 Nm using torque wrench - VAG1331 (or equivalent).

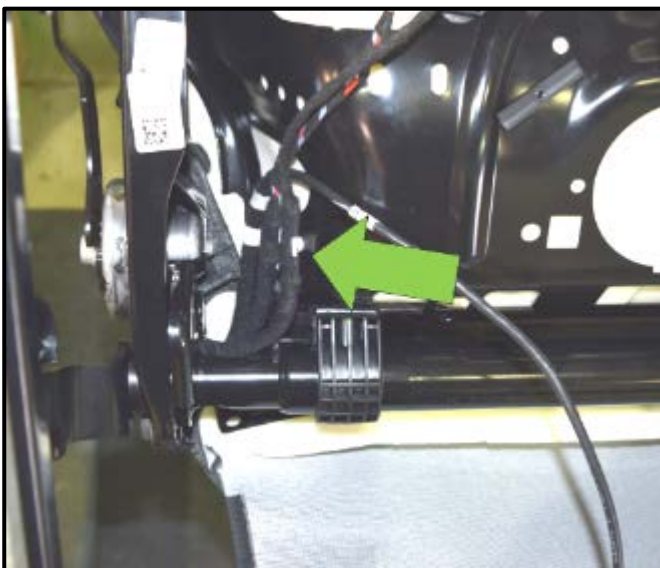

- Reattach the wiring harness retainers located in the area near the seatback hinge <arrow>.

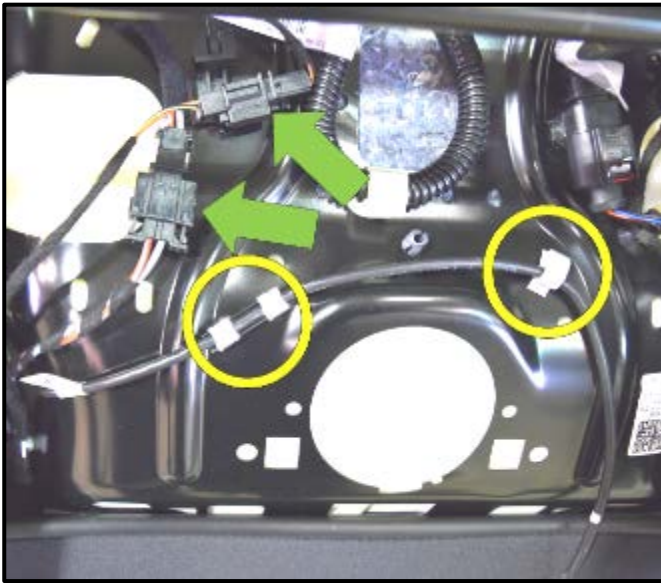

- Reconnect all electrical connectors <arrows> between the seat bottom and the seatback.
- Secure the airbag wiring harness retainers <circles> to the seat bottom pan.

NOTE

The number of electrical connectors between the seat bottom and the seatback may vary based on vehicle equipment.

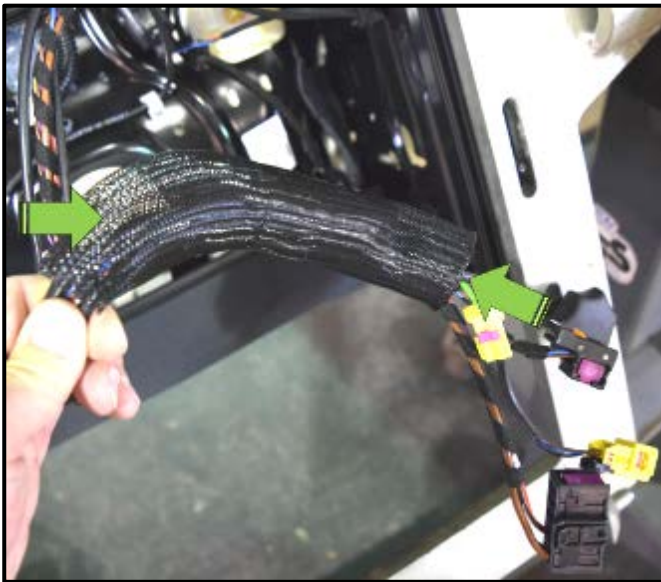

- Compress the wiring harness sheath together to expand it <direction of arrows>.
- Route the airbag wiring harness and connector through the wiring harness sheath.

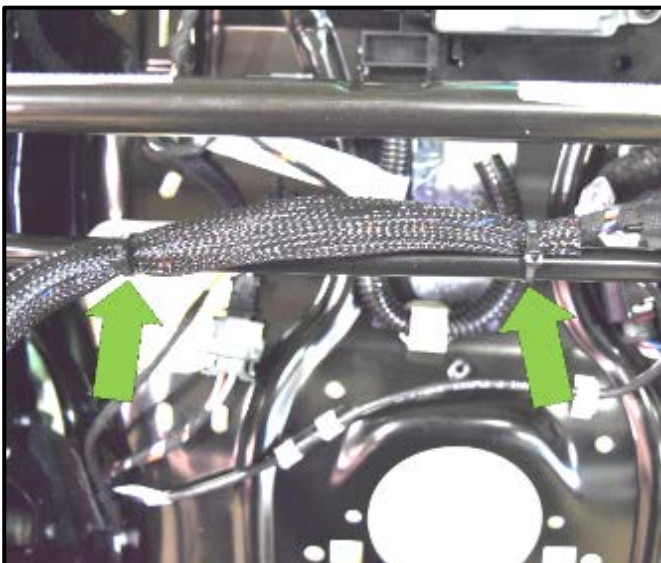

- Secure the wiring harness sheath to the seat frame at the locations shown using two tie-wraps <arrows>.

Part Number	Part Description
N 020 90 22	Cable Tie

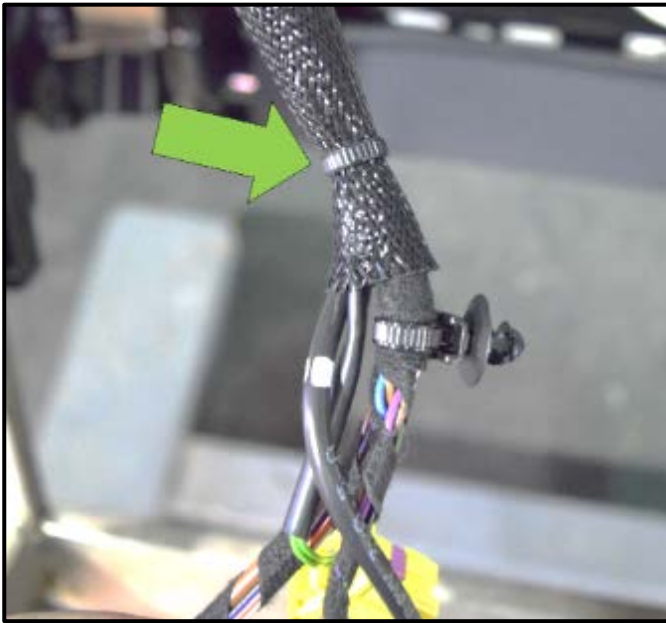

- Secure the lower end of the wiring harness sheath at the location shown using a tie-wrap <arrow>.

Part Number	Part Description
N 020 90 22	Cable Tie

Proceed to Section G

Section F – Non - Forward Folding Seatback Installation

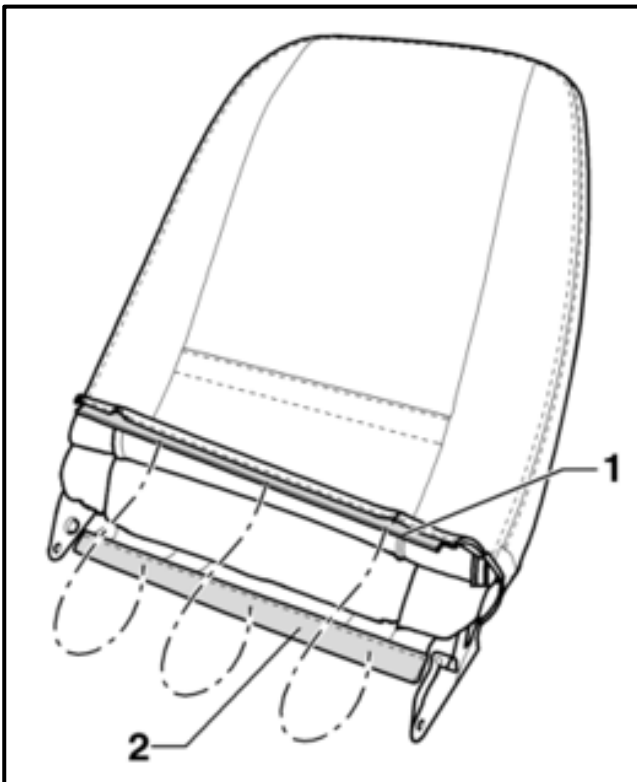

- Reattach the contact surface <1> to the mount <2>.

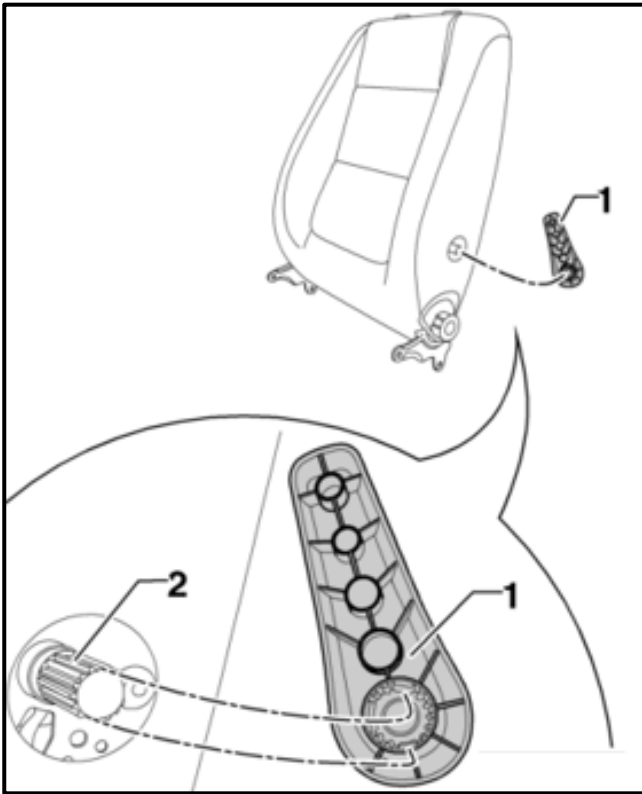

- If equipped, reinstall the lumbar adjustment lever <1> onto the shaft <2>, ensuring the splines in the lumbar adjustment lever align with the splines on the shaft.



- Align the seatback to the seat bottom, tilting the seatback forward and resting it against the seat bottom as shown.
- Reinstall the front mounting bolts <arrow 1> to both seatback hinges, but do not tighten.

i TIP

To aid in proper reassembly, reference the wiring harness routing and orientation noted prior to disassembly.



- Properly route the seat and airbag wiring harnesses through the seat bottom <arrow>.



- Tilt the seatback rearward and reinstall the rear mounting bolt into position <arrow 2> on both seatback hinges.
- Torque both bolts <arrows 1 & 2> on both sides to 34.5 Nm using torque wrench - VAG1331 (or equivalent).

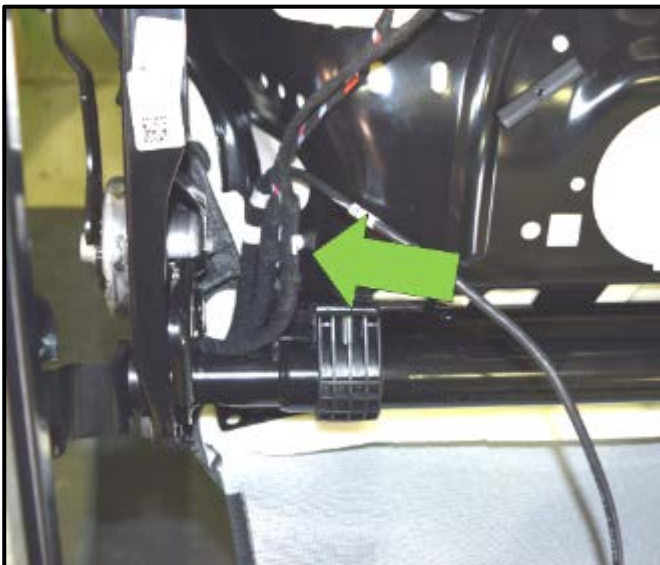

- Reattach the wiring harness retainers located in the area near the seatback hinge <arrow>.

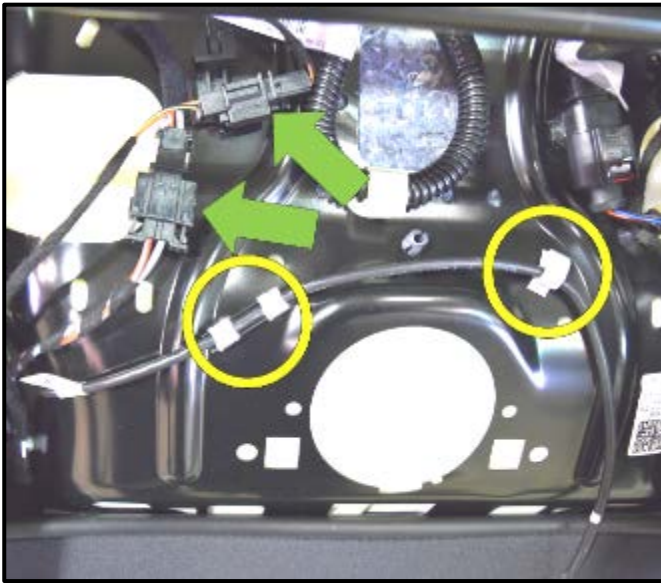

- Reconnect all electrical connectors <arrows> between the seat bottom and the seatback.
- Secure the airbag wiring harness retainers <circles> to the seat bottom pan.

NOTE

The number of electrical connectors between the seat bottom and the seatback may vary based on vehicle equipment.

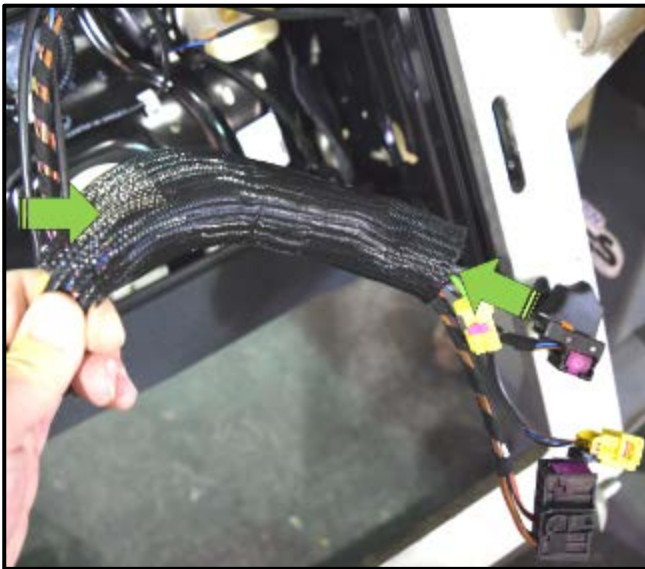

- Compress the wiring harness sheath together to expand it <direction of arrows>.
- Route the airbag wiring harness and connector through the wiring harness sheath.

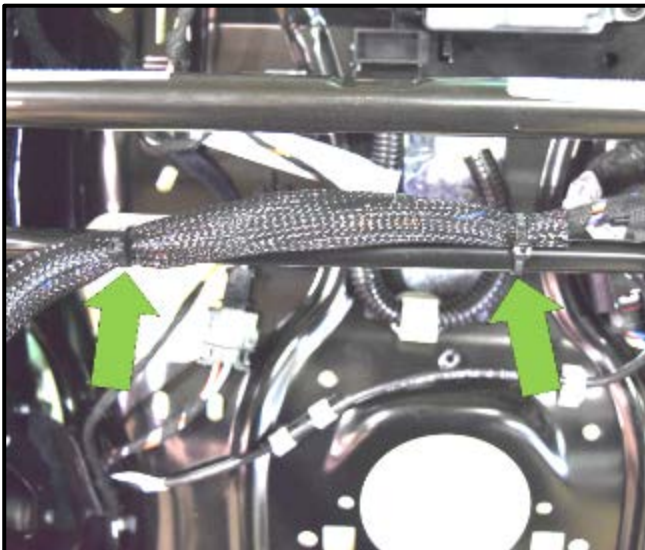

- Secure the wiring harness sheath to the seat frame at the locations shown using two tie-wraps <arrows>.

Part Number	Part Description
N 020 90 22	Cable Tie

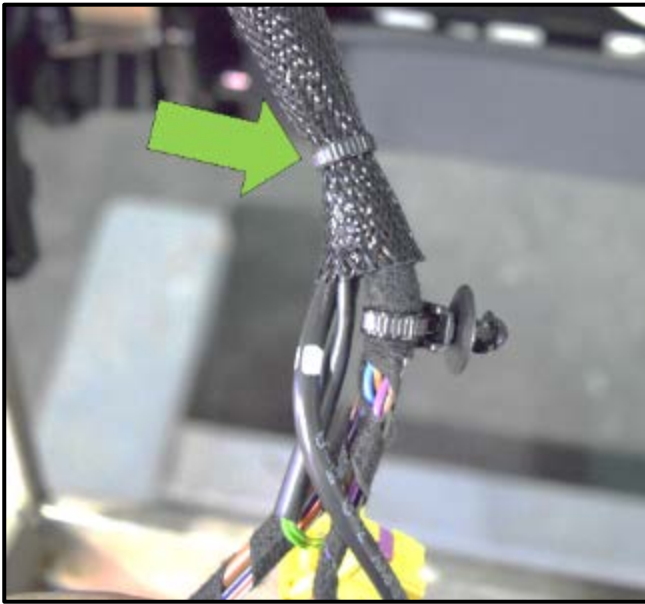

- Secure the lower end of the wiring harness sheath at the location shown using a tie-wrap <arrow>.

Part Number	Part Description
N 020 90 22	Cable Tie

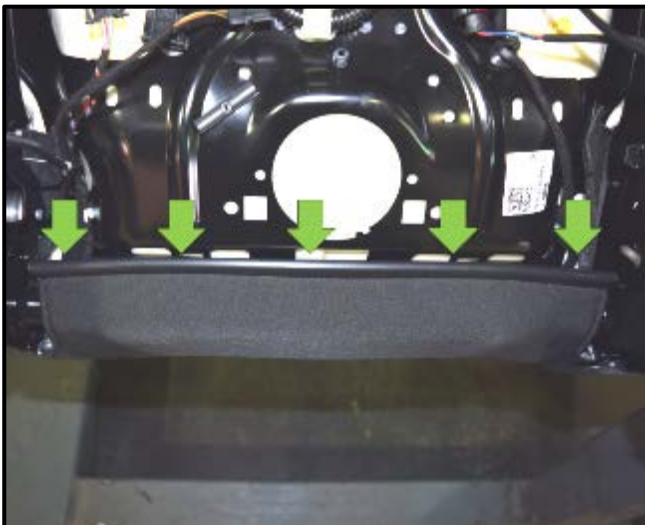

- Reattach the lower seat cover channel to the seat bottom pan <arrows>.

Proceed to Section G

Section G – Seat Assembly and Reinstallation

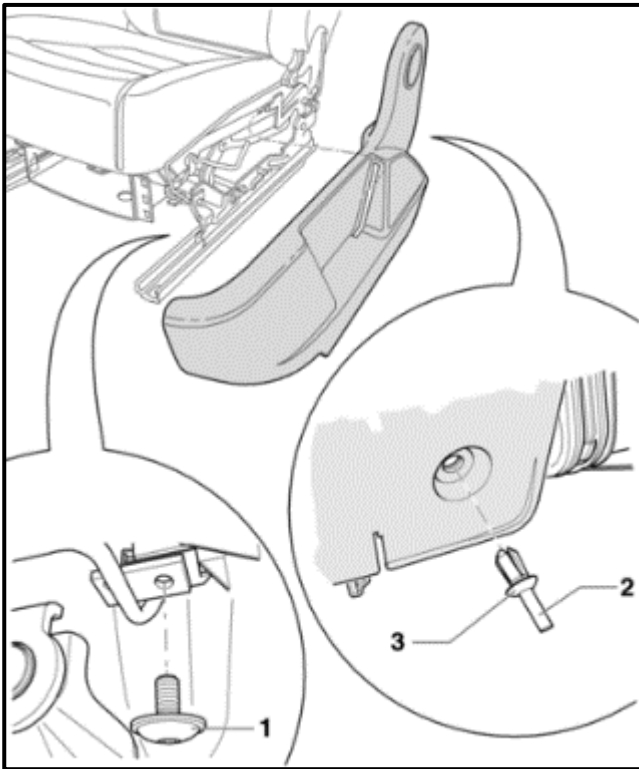

- If reinstalling the driver seat, align the sill side trim panel to the seat frame as shown.
- Reconnect all electrical connectors between the trim panel and the seat.
- Reinstall the expanding clip <3>.
- Push the clamping pin <2> inward and reinstall it into the expanding clip.
- Reinstall the screw <1> and torque to 2 Nm using torque wrench - VAG1783 (or equivalent).

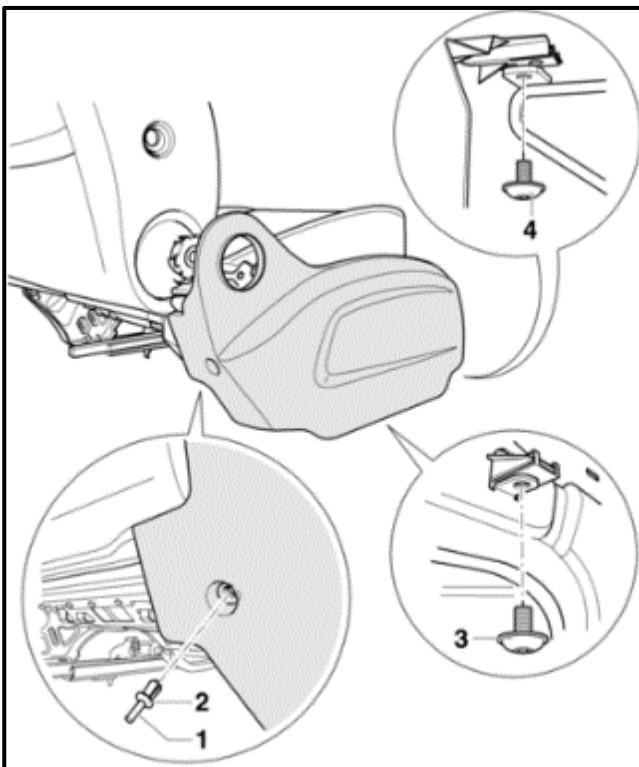

- If reinstalling the passenger seat, align the sill side trim panel to the seat frame as shown.
- Reinstall screws <3 and 4> and torque to 2 Nm using torque wrench - VAG1783 (or equivalent).
- Reinstall the expanding clip <2>.
- Push the clamping pin <1> inward and reinstall it into the expanding clip <2>.

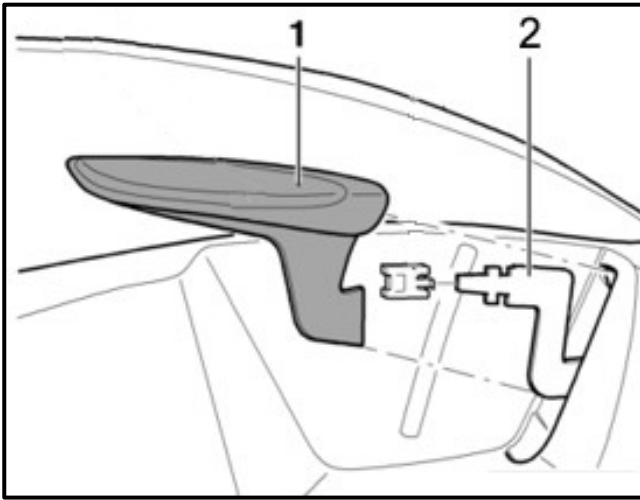

- If equipped, reinstall the adjustment handle <1> to the adjusting lever <2>.

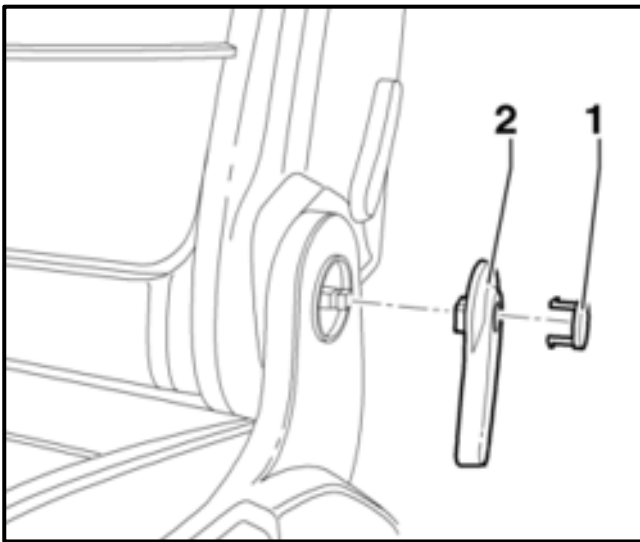

- If equipped, reinstall the release lever <2> and then the release lever cap <1>.

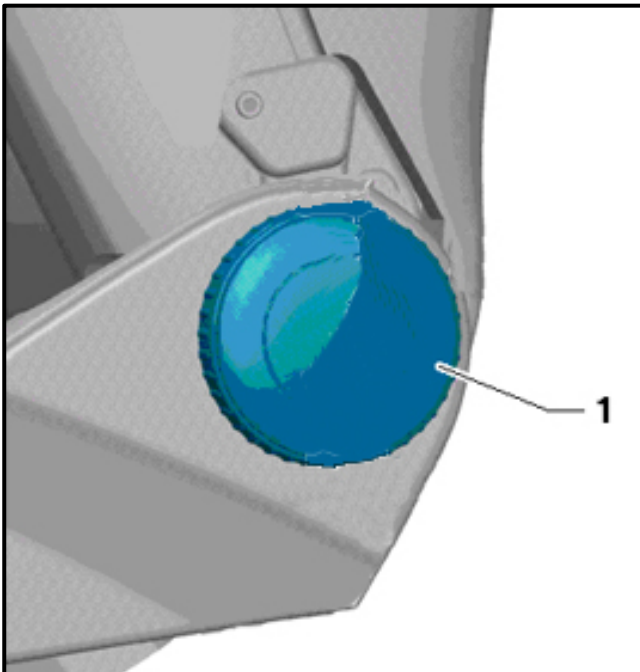

- If equipped, reinstall the backrest adjustment wheel <1> (replace the wheel if it is excessively loose after installation).

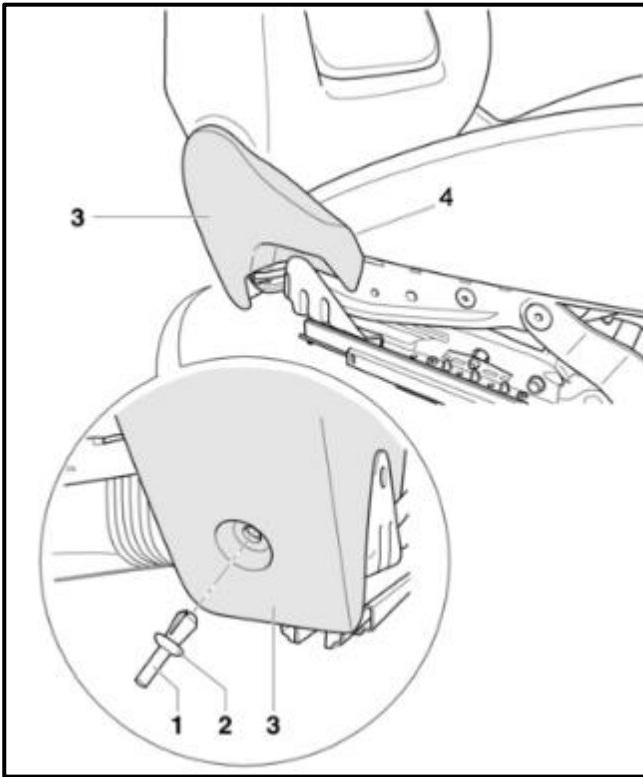

- Align the trim <3> to the seat frame.
- Reattach the clip <4> retaining the trim <3> to the seat frame.
- Reinstall the expanding clip <2>.
- Push the clamping pin <1> inward and reinstall it into the expanding clip <2>.

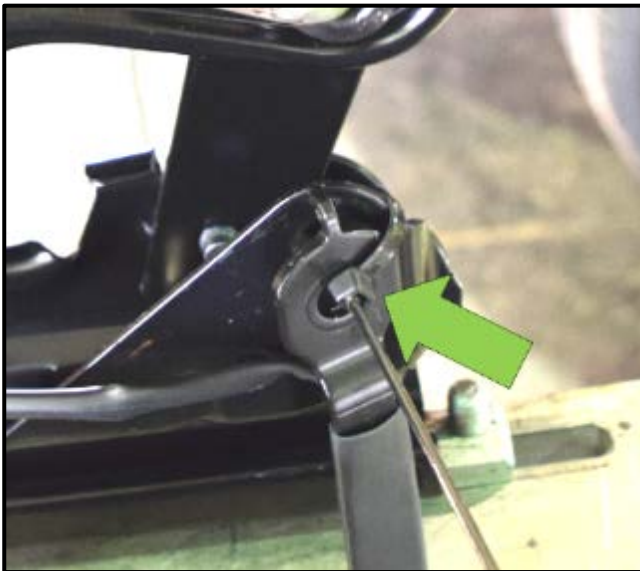

! NOTE

During seat assembly, DO NOT allow the seat belt latch to hang freely by the wiring harness. Failure to do so may result in damage to the wiring harness, which is NOT covered under this action.

- Carefully remove the tie wrap <arrow> used to fasten the seat belt latch to the seat frame during disassembly.

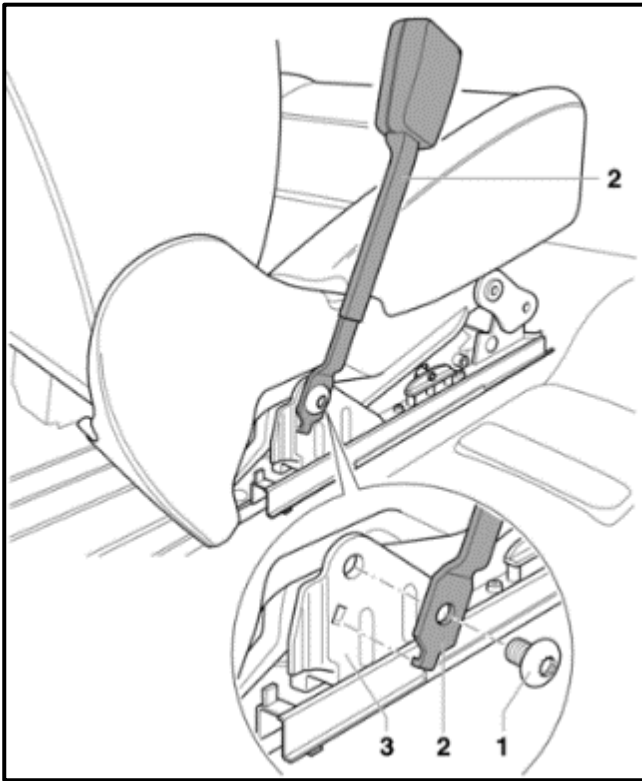

- Reinstall the seat belt latch <2> to the mount in the seat frame <3>.
- Reinstall the mounting bolt <1> and torque to 40 Nm using torque wrench - VAG1331 (or equivalent).

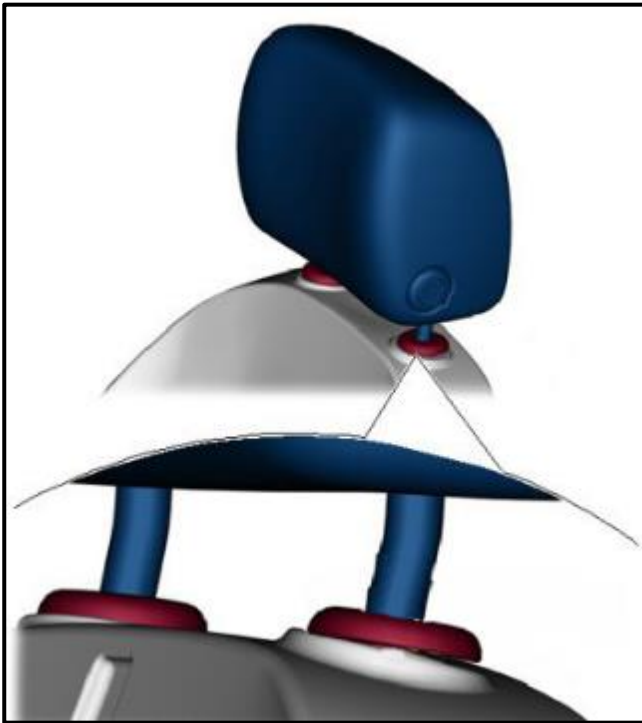

- Reinstall the headrest to the seat, ensuring it is fully seated.



- Remove the seat from the Engine /Transmission Holder – Seat Repair Fixture VAS6136.

! NOTE

- Due to the weight and size of the front seat, assistance from a second technician may be helpful in installing the seat.
- While lifting the seat into the vehicle, it must not be grasped by the attachments (i.e. seat belt latch, seat adjustment lever(s), seat trim panels, etc.). Damage to these components is NOT covered under this action.
- Use care when installing the seat to not damage the threads in the mounting plate of the seat crossmember.



- Before reinstalling the front seat, ensure the Universal Vehicle Protector - VAS871 001 remains in place <as shown> to protect the sill panel during installation.
- Carefully lift the seat into the vehicle through the door opening.
- Insert the seat into corresponding openings in floor via the centering pins on the tunnel-side.
- Once the seat has been placed into the vehicle, remove the Universal Vehicle Protector - VAS871 001.

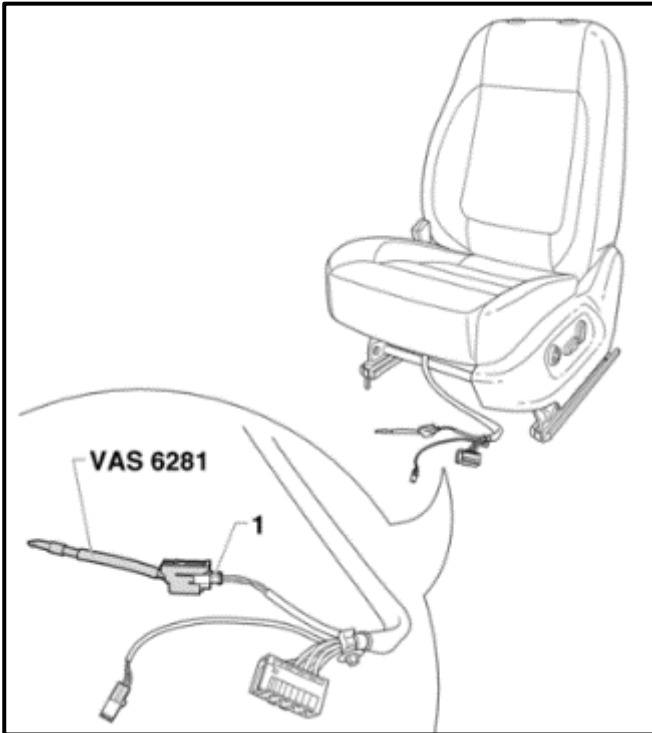
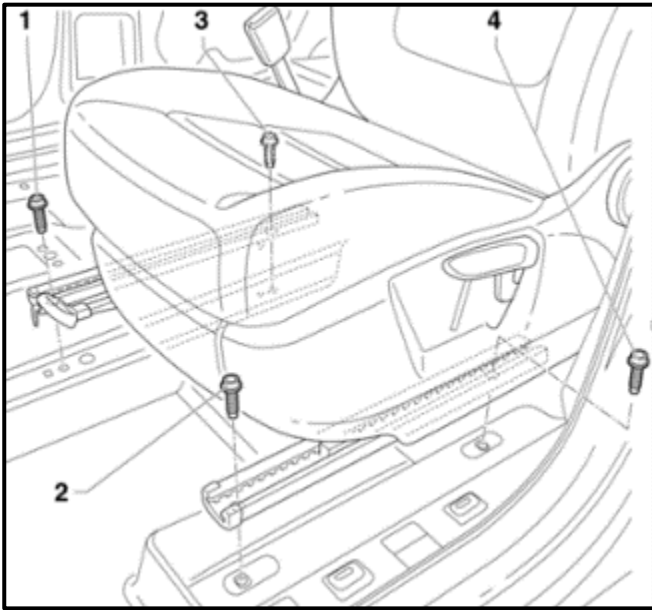

NOTE

- Prior to installing the seat bolts, ensure that the threads and bolt holes are clean and free of debris.
- When installing the bolts, initially install them by hand and only tighten with hand tools. DO NOT install or tighten with an impact wrench, air ratchet, etc.

- Reinstall bolts <1 and 2>.

- Remove the Airbag Lockout Adapter VAS6281 from the airbag wiring harness as shown <1>.
- Reconnect the seat and airbag wiring harness connectors to the connector station in the carpet.
- Secure the wiring harness to the floor mount.

WARNING

The ignition must be on when connecting the battery. If pyrotechnic components (for example, airbag, belt tensioner) are not repaired correctly, they may deploy unintentionally after connecting battery. To reduce the risk of injury, there must not be anyone in the vehicle interior when connecting the battery.

- Ensure the ignition is still switched ON.
- Reconnect the vehicle battery.
- Close the battery cover.

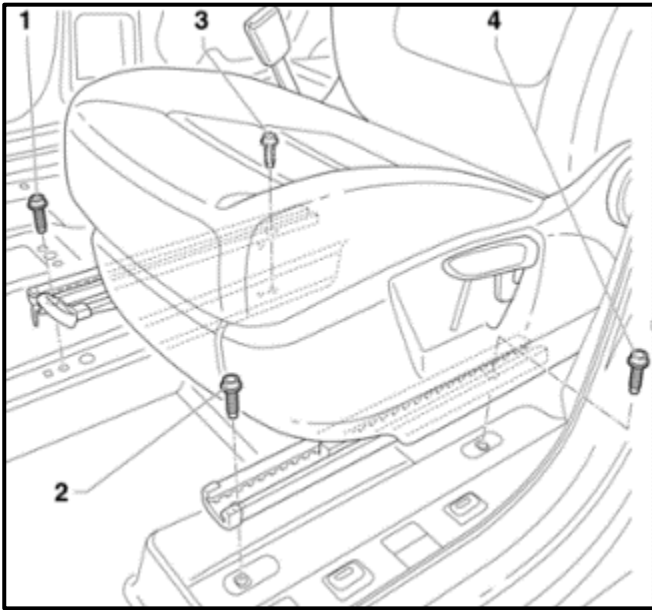

- Position the seat as far forward as possible using the forward/back adjustment.

NOTE

- Prior to installing the seat bolts, ensure that the threads and bolt holes are clean and free of debris.
- When installing the bolts, initially install them by hand and only tighten with hand tools. DO NOT install or tighten with an impact wrench, air ratchet, etc.

- Reinstall bolts <3 and 4>.
- Torque all bolts <1, 2, 3 and 4> to 40 Nm using torque wrench - VAG1331 (or equivalent).

NOTE

If vehicle has both criteria (01 and 02) repeat section B for remaining seat.

- Reset relevant vehicle settings (i.e. one-touch windows, clock, etc.)

Proceed to Section H

Section H - MANDATORY Parts Return

IMPORTANT!

**DO NOT detonate the airbags prior to return.
Airbags MUST be returned intact and remain in their as-removed state.**

- All side airbags replaced under this Action 69V8 must be returned to the designated inspection facility. Requests for all side airbags will be available in the Warranty Parts Portal (WPP) once the claim has reached approved status in SAGA.
- Use the Warranty Parts Portal to obtain the FedEx shipping label and required hazardous material documentation.
- Side airbags not returned or improperly returned are subject to claim cancellation.

Appendix A – Warning and Safety Precautions

WARNING

Electrostatic discharges can lead to unintended deployment of the airbag. The technician must discharge static electricity prior to handling pyrotechnic components (for example, airbag, belt tensioner) or disconnecting the ignition wire and ground wire. This is done, for example, by briefly touching the body or door striker.

WARNING

It is only necessary to use hand tools to remove the seat. DO NOT remove seat mounting bolts with an impact wrench, air ratchet, etc. as this may result in accidental airbag deployment. Any unintended airbag/pyrotechnic device deployment is not covered under this action.

WARNING

The ignition must be on when connecting the battery. If pyrotechnic components (example: airbag, belt tensioner) are not repaired correctly, they may deploy unintentionally after connecting battery. To reduce the risk of injury, there must not be anyone in the vehicle interior when connecting the battery.

WARNING

When working on vehicles with the ignition already switched on or that are ready to drive there is a danger of the engine starting unexpectedly and of being poisoned by gas in enclosed areas. Risk of body parts and/or clothing being clamped or pulled.

Perform the following before switching on the ignition:

- Move the selector lever into P.
- Activate the parking brake
- Turn off the ignition.
- Open the hood
- Connect Battery Charger -VAS5095A- to the battery jump start terminal.
- Turn on the ignition.

WARNING

When installing the seat, if a thread in mounting plate of seat crossmember was damaged, a reworking of the damaged thread is forbidden. In this case, the seat crossmember mounting plate must be replaced.

CAUTION

- Testing, removing, installing, and repair work may only be performed by qualified personnel.
- There is no change interval for airbag units.
- Never test with a test light, volt meter, or ohm meter.
- The pyrotechnic components may be checked only when they are installed with an approved vehicle diagnosis, testing, and information system.
- When working on the Airbag System, the battery ground cable must be disconnected WITH THE IGNITION SWITCHED ON. Then cover the negative battery terminal.
- Prior to beginning other work on the airbag system, wait for 10 seconds after disconnecting the battery.
- The ignition must be SWITCHED ON when connecting the battery.

- No one should be inside the vehicle when reconnecting the battery.
 - Exception: Vehicles with a battery located inside the passenger compartment.
- Wash hands after touching ignited restart system pyrotechnic components.
- Pyrotechnic components may not be opened nor repaired; always use new parts (risk of injury).
- Pyrotechnic components that have fallen onto a hard surface or show signs of damage must not be installed in the vehicle.
- Do not leave the pyrotechnic component out unattended.
- When connecting restraint system pyrotechnic components, only the person performing the work should be inside the vehicle.
- Do not use any grease or cleaning solutions on pyrotechnic components.
- Replace the airbag unit if any contaminants such as oil, grease, paint, or dye cleaning solution have penetrated the fabric.
- Pyrotechnic components must not be exposed to temperatures over 100°C (212°F), even for a short time.
- Store the driver and front passenger airbag units in the uninstalled state so that the cushioned side faces upward.
- Airbag units should be installed immediately upon removal from shipping package.
- When replacing airbag units, the following sequence must be followed exactly:
 - Remove the old airbag unit and store with the upholstered/cushioned side facing up.
 - Remove the new airbag unit from the transport container and store it with the upholstered/cushioned side facing up.
 - Place the old airbag unit in the transport container immediately.
 - Install the new airbag unit in the vehicle.
 - Airbag unit is to be returned to the shipping package if there is an interruption in work.