

Karma Part Numbering Decoders

Date: August 2017

Revised: December 2018

Priority: All Karmas in operation

Applicability: All variants

Market Regions: All

Purpose: This is a general information bulletin, to decode the meaning behind the part numbering scheme and color codes.

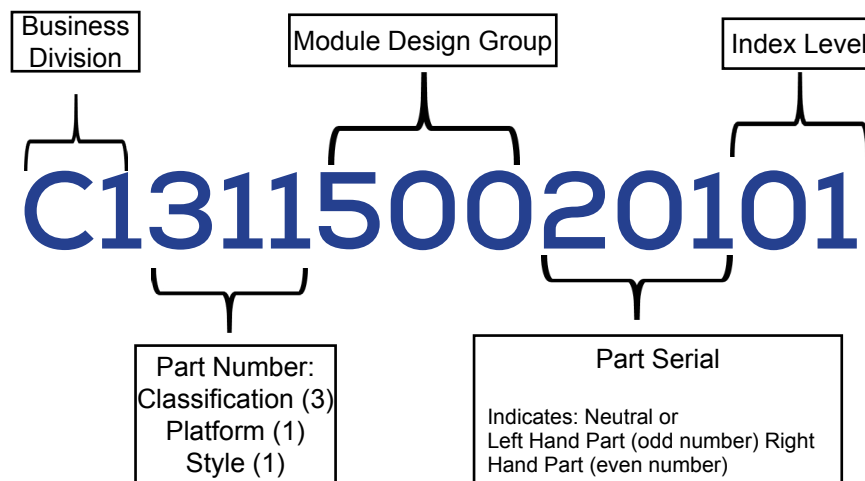

The numbering graphic above is broken down the digit locations are described as such:

Business Division - indicates what branch of Karma Automotive LLC that has originated this part. Either “B1” (Custom) or “C1” (Automotive)

Part Number - Classification, Platform, Style - describes what this part number refers to as in the table below.

Design Group - designates which engineering module group has ownership of the part, from design to final build, and sourcing.

Part Serial - indicates either a neutral, Left Hand (odd number) or Right Hand (even) part. An odd serial number can be either a neutral or LH part.

Index level - Indicates when there is a form (shape and color), fit, or function change to the part used in production. Typically this will not affect the part for the owner experience unless it is designated as such, and previous index will be scrapped from production and possibly service centers as well.

Color Code or CC - This can be added to parts as a suffix to indicate color code, exterior parts have various codes, and interior parts have a mix of different two letter combinations to indicate color.

For exterior body paint and related information see: **SC-17-01-12 Exterior colors and Paint**”.

Any questions can be sent by email to parts@karmaautomotive.com

Karma Automotive Bulletins and service documents are intended for use by experienced and trained Technicians. If you lack the skills, tools, equipment and a suitable workshop for any procedure described in this document, we suggest you leave such repairs to a Karma retailer and service provider. See your service provider for advice on whether your vehicle may benefit from the information contained within this document. The information contained in the Karma Bulletin is accurate at the date of publication. However, Karma Automotive regularly updates technical information. Please check with your Karma Automotive Retailer and Karma Automotive service provider that the bulletin you intend to use contains the latest available information.

Karma Part Numbering Decoders

Date: August 2017

Revised: December 2018

The tables below correspond the the part number scheme to provide more detail.

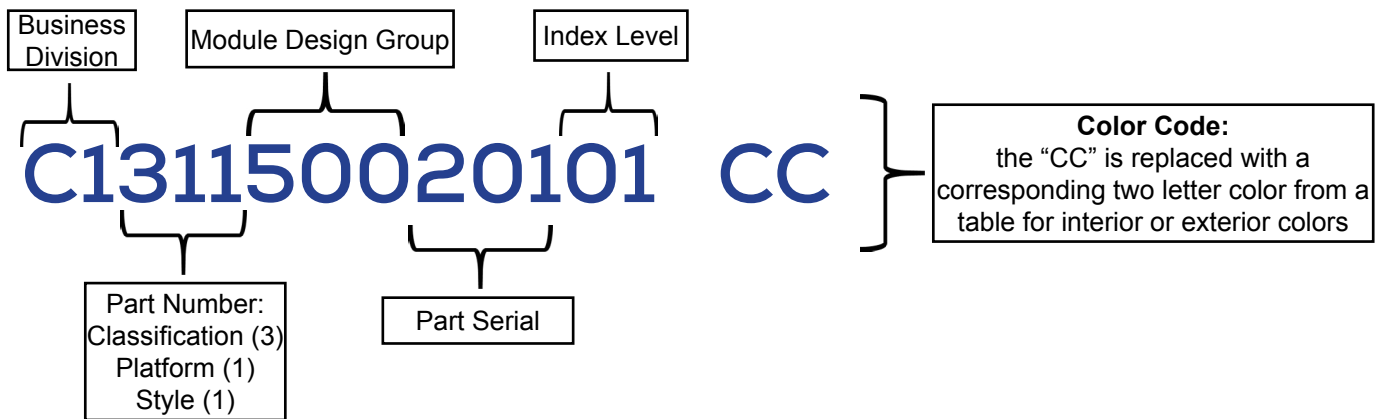

Module Design Group	Name
1	Powertrain
2	Chassis
3	Thermal
4	Interior
5	Body Structures
6	Body Closures
7	Body Exterior
8	Info and Controls
9	Electrical

Automotive Classification	Description
1 - Styling Surface	Defined by craftsmanship
2 - Aftermarket Accessory	Not used in production, only ordered by dealer or customer
3 - Production Part	Parts used on vehicle, with information proprietary to Karma
4 - Standard Part	No proprietary information (Fasteners, standard fluids, etc.)
5 - Special Tools/ Equipment	Unique service part numbers (not used in production or assemblies)
6 - Service Kits	Service Specific Part (oil filter, air filter etc.)
7 - Temporary Part Number	A number created for temporary cases (Karma only)
8 - Document(s)	Studies, Test Reports, FMEA, PAD, processes, Standards, work instructions, etc.
9 - Software	Not a physical part

Karma Automotive Bulletins and service documents are intended for use by experienced and trained Technicians. If you lack the skills, tools, equipment and a suitable workshop for any procedure described in this document, we suggest you leave such repairs to a Karma retailer and service provider. See your service provider for advice on whether your vehicle may benefit from the information contained within this document. The information contained in the Karma Bulletin is accurate at the date of publication. However, Karma Automotive regularly updates technical information. Please check with your Karma Automotive Retailer and Karma Automotive service provider that the bulletin you intend to use contains the latest available information.

Karma Part Numbering Decoders

Date: August 2017

Revised: December 2018

Brake calipers have their own Color Code (CC) table, shown below.
Accessories Wheels have a corresponding Color Codes as seen in the Accessories catalog.

Caliper Color	Code
Charcoal Grey Metallic	XF
Orange	MD
Dark Orange (Aliso Edition not shown)	MG
Blue	BG
Metallic Silver	SJ
Yellow	YD
Red	RD



XF



MD



BG



YD



SJ



RD

Karma Automotive Bulletins and service documents are intended for use by experienced and trained Technicians. If you lack the skills, tools, equipment and a suitable workshop for any procedure described in this document, we suggest you leave such repairs to a Karma retailer and service provider. See your service provider for advice on whether your vehicle may benefit from the information contained within this document. The information contained in the Karma Bulletin is accurate at the date of publication. However, Karma Automotive regularly updates technical information. Please check with your Karma Automotive Retailer and Karma Automotive service provider that the bulletin you intend to use contains the latest available information.

Karma Part Numbering Decoders

Date: August 2017

Revised: December 2018

Interior colors are coded by color package (multiple color items such as Seat assemblies, consoles, door panels) and by component color. Palisades Qr code is composed of Black Sand (KA) parts.

Color Package	Multi Color Code	Interior Trim Code
Palisades	QR	5K
Palisades Sport	QT	6K
Crystal Cove	QK	3Y
Salt Creek	QU	4N
Coronado	QP	4M
Canyon	QA	1M
Sea Horizon (Aliso Edition)	UH	3B

Interior Component Color	Code
Black Sand	KA
Clay	MB
Bark	NA
Sand	NL
Beach	NK
Bone	WA
Madiera Red	RE
Nightfall	BH

Palisades

Package Color Code QR



- 1 Black Sand KA
Seat Entire: QR
Door Panel: Palisades QR
IP Entire: Upper, Inner, Lower
B Pillar: Upper, Center
Package Tray
Center Console
- 2 Black Sand KA
Door Speaker Grille
Package Tray Speaker Grille
Seat Side Shields
SW Airbag Cover
- 3 Black Sand KA
Garnish
B Pillar Lower
Steering Wheel Shroud
- 4 Black Sand
Steering Wheel
- 5 Black Sand KA
- 6 Black Sand KA
- 7 * Black Sand KA
A & C Pillars
Headliner
Sun Visors
- 8 Z A Carbon Fiber

Karma Automotive Bulletins and service documents are intended for use by experienced and trained Technicians. If you lack the skills, tools, equipment and a suitable workshop for any procedure described in this document, we suggest you leave such repairs to a Karma retailer and service provider. See your service provider for advice on whether your vehicle may benefit from the information contained within this document. The information contained in the Karma Bulletin is accurate at the date of publication. However, Karma Automotive regularly updates technical information. Please check with your Karma Automotive Retailer and Karma Automotive service provider that the bulletin you intend to use contains the latest available information.

Karma Part Numbering Decoders

Date: August 2017

Revised: December 2018

Palisades Sport Package- is QT, composed of Black Sand (KA) and Madeira Red (RE) with a Carbon Fiber Jewel trim piece (#9 in image below).

Palisades Sport Package Color Code - QT



- 1 Black Sand KA**
Seats: QT
Doors: QT
IP: Upper
B Pillar Upper
Package Tray
- 2A Red Perf Leather**
Seats: QT
Doors: QT
Center Console:
- 2B Madeira Red**
IP: Inner
Door: Inner
B Pillar: Center
Center Console:
- 3 Black Sand KA**
Door Speaker Grille
Package Tray Speaker Grille
Seat Side Shields
SW Airbag Cover
- 4 Black Sand KA**
Garnish
B Pillar Lower

Steering Wheel Shroud
- 5 Black Sand KA**
Steering Wheel
- 6 Red Seatbelt Webbing**
- 7 Black Sand KA**
- 8 Black Sand KA**
A & C Pillars
Headliner
Sun Visors
- 9 Carbon Fiber**
- 10 Red Accent Thread**

Karma Automotive Bulletins and service documents are intended for use by experienced and trained Technicians. If you lack the skills, tools, equipment and a suitable workshop for any procedure described in this document, we suggest you leave such repairs to a Karma retailer and service provider. See your service provider for advice on whether your vehicle may benefit from the information contained within this document. The information contained in the Karma Bulletin is accurate at the date of publication. However, Karma Automotive regularly updates technical information. Please check with your Karma Automotive Retailer and Karma Automotive service provider that the bulletin you intend to use contains the latest available information.

Karma Part Numbering Decoders

Date: August 2017

Revised: December 2018

Crystal Cove Package is QK, composed of Beach (NK) and Sand (NL) the headliner is Bone (WA) as shared in Salt Creek, this is just an over view of the color codes for the interior. Again send an email to have specific questions answered.

Crystal Cove Package Color Code - QK



- 1 Beach NK**
Door: Upper, Lower
IP: Upper, Lower
B Pillar: Upper,
Package Tray
- 2 Sand NL**
Seat: Inner

IP: Inner
B Pillar: Center
Center Console:
- 3 Beach NK**
Door Speaker Grille
Package Tray Speaker Grille
Seat Side Shields
- 4 Sand NL**
SW Airbag Cover
- 5 Beach NK**
Garnish
B Pillar Lower

Steering Wheel Shroud
- 6 Beach NK**
Steering Wheel Rim
- 7 Beach NK . Seatbelt Webbing**
- 8 Beach NK . Carpet**
- 9 Bone WA**
A & C Pillars
Headliner
- 10 Fallen Wood**

Karma Automotive Bulletins and service documents are intended for use by experienced and trained Technicians. If you lack the skills, tools, equipment and a suitable workshop for any procedure described in this document, we suggest you leave such repairs to a Karma retailer and service provider. See your service provider for advice on whether your vehicle may benefit from the information contained within this document. The information contained in the Karma Bulletin is accurate at the date of publication. However, Karma Automotive regularly updates technical information. Please check with your Karma Automotive Retailer and Karma Automotive service provider that the bulletin you intend to use contains the latest available information.

Karma Part Numbering Decoders

Date: August 2017

Revised: December 2018

Salt Creek Color package QU, is mainly composed of Back Sand (KA) and Bone (WA) pieces.

Salt Creek

Package Color Code - QU

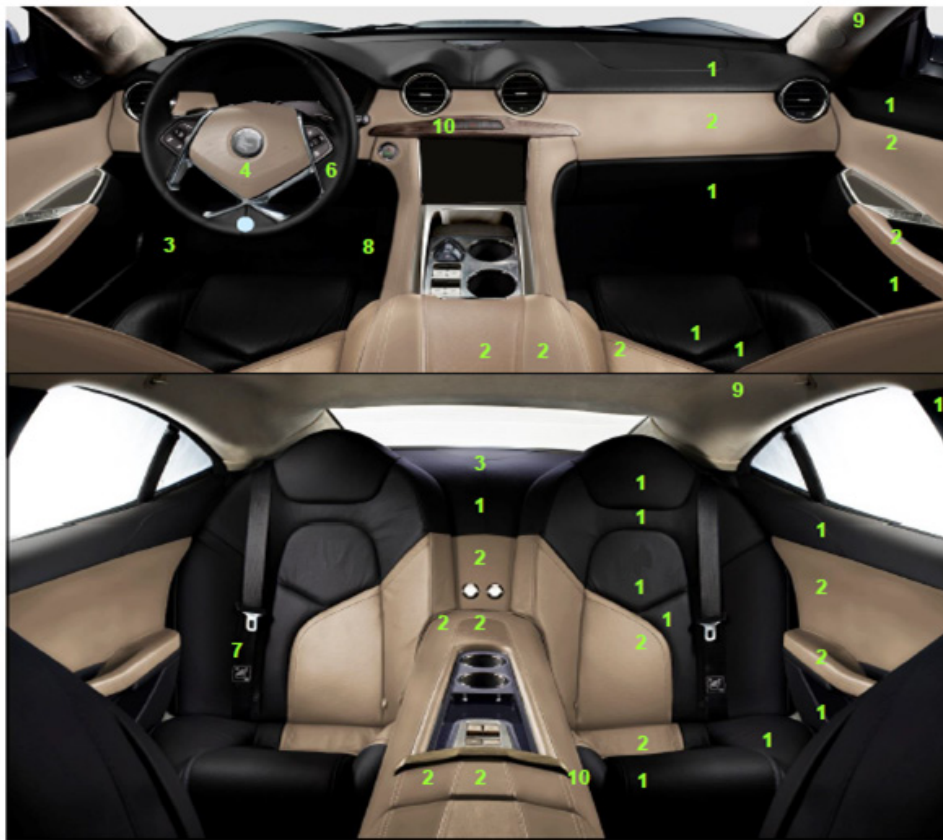

- 1 Black Sand KA**
 Seat: QU
 Door: Upper, Lower
 IP: Upper, Lower
 B Pillar: Upper,
 Package Tray
- 2 Bone WA**
 Seat: QU
 Door: Inner, Armrest
 IP: Inner
 B Pillar: Center
 Center Console Entire: Inner, Outer
- 3 Black Sand KA . Paint . United Paint**
 Door Speaker Grille
 Package Tray Speaker Grille

 Seat Side Shields
- 4 Bone WA**
 SW Airbag Cover
- 5 Black Sand KA**
 Gamish
 B Pillar Lower

 Steering Wheel Shroud
- 6 Black Sand KA**
 Steering Wheel Rim
- 7 Black Sand KA . Seatbelt Webbing**
- 8 Black Sand KA . Carpet**
- 9 Bone Suede WA . Headliner**
 A & C Pillars
 Headliner
- 10 Rescued Wood ZN**

Karma Automotive Bulletins and service documents are intended for use by experienced and trained Technicians. If you lack the skills, tools, equipment and a suitable workshop for any procedure described in this document, we suggest you leave such repairs to a Karma retailer and service provider. See your service provider for advice on whether your vehicle may benefit from the information contained within this document. The information contained in the Karma Bulletin is accurate at the date of publication. However, Karma Automotive regularly updates technical information. Please check with your Karma Automotive Retailer and Karma Automotive service provider that the bulletin you intend to use contains the latest available information.

Karma Part Numbering Decoders

Date: August 2017

Revised: December 2018

Coronado package is color coded QP, and is composed largely of Clay (MB) and Black Sand (KA) components. Note that multi colored items (a mix of Clay and Black Sand) are coded as QP.

Coronado

Package Color Code - QP



- 1 Black Sand KA**
 Seat: QP
 Door: Upper, Armrest
 IP: Upper, Inner
 B Pillar: Upper, Center
 Package Tray
 Center Console: .
- 2 Clay MB**
 Seat: QP
 Door:
 IP: Lower
 Center Console:
- 3 Black Sand KA** .
 Door Speaker Grille
 Package Tray Speaker Grille

 Seat Side Shields
 SW Airbag Cover
- 4 Black Sand KA** .
 Garnish
 B Pillar Lower

 Steering Wheel Shroud
- 5 Black Sand KA** .
 Steering Wheel Rim
- 6 Black Sand KA** . Seatbelt Webbing .
- 7 Black Sand KA** . Carpet .
- 8 Black Sand KA** . Headliner
 A & C Pillars
 Headliner
 Sun Visors
- 9 Fallen Wood** .
- 10 Clay Accent Thread**

Karma Automotive Bulletins and service documents are intended for use by experienced and trained Technicians. If you lack the skills, tools, equipment and a suitable workshop for any procedure described in this document, we suggest you leave such repairs to a Karma retailer and service provider. See your service provider for advice on whether your vehicle may benefit from the information contained within this document. The information contained in the Karma Bulletin is accurate at the date of publication. However, Karma Automotive regularly updates technical information. Please check with your Karma Automotive Retailer and Karma Automotive service provider that the bulletin you intend to use contains the latest available information.

Karma Part Numbering Decoders

Date: August 2017

Revised: December 2018

Canyon Package is coded as QA, this is composed of various pieces primarily Bark (NA) and Clay (MB) pieces.

Canyon

PACKAGE CODE QA

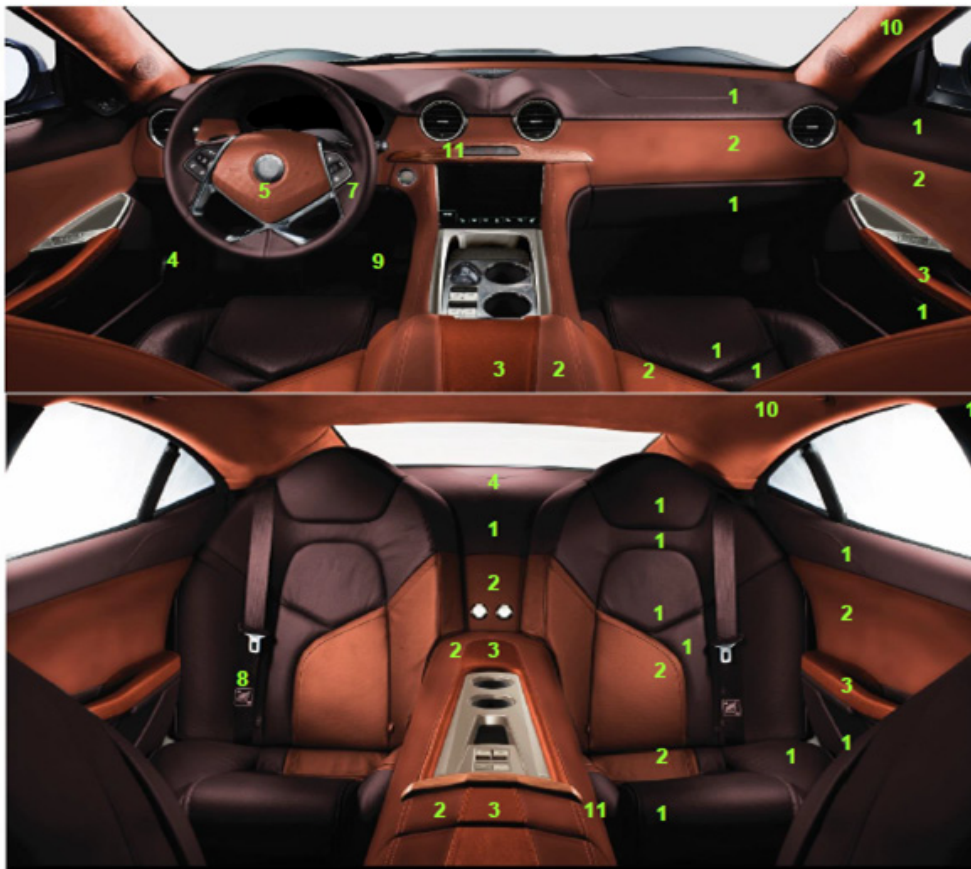

- 1 Bark NA .**
Seat: QA
Door:
IP: Upper, Lower
B Pillar: Upper,
Package Tray
- 2 Clay MB .**
Seat: QA
Door:
IP: Inner
B Pillar: Center
Center Console Entire:
- 3 Sun MA .**
Door: Armrest
Center Console
- 4 Bark NA .**
Door Speaker Grille
Package Tray Speaker Grille
Seat Side Shields
- 5 Clay MB .**
SW Airbag Cover
- 6 Bark NA .**
Gamish
B Pillar Lower

Steering Wheel Shroud
- 7 Bark NA**
Steering Wheel Rim
- 8 Bark NA . Seatbelt**
- 9 Bark NA . Carpet**
- 10 Clay MB**
A & C Pillars
Headliner
- 11 Fallen Wood .**

Karma Automotive Bulletins and service documents are intended for use by experienced and trained Technicians. If you lack the skills, tools, equipment and a suitable workshop for any procedure described in this document, we suggest you leave such repairs to a Karma retailer and service provider. See your service provider for advice on whether your vehicle may benefit from the information contained within this document. The information contained in the Karma Bulletin is accurate at the date of publication. However, Karma Automotive regularly updates technical information. Please check with your Karma Automotive Retailer and Karma Automotive service provider that the bulletin you intend to use contains the latest available information.