



FIELD SERVICE CAMPAIGN – 18121

18 December 2018

SUBJECT:

Front Axle Left-Side Spring Spacer

MODELS INVOLVED:

International® MV™ Series and DuraStar®

DEFECT DESCRIPTION:

Certain MV™ Series and DuraStar® models may have been built with an incorrect spacer for the left-side front axle spring resulting in a lean condition.

ELIGIBILITY:

This procedure applies ONLY to vehicles marked in the International® Service PortalSM with FSC 18121. Also complete any other open campaigns listed on the Service Portal at this time.

TOOLS REQUIRED:

No Special Tools Required

PARTS REQUIRED:

| Part Number | Description | Quantity |
|-------------|---|----------|
| 2512808C1 | Spacer – 3” x 1/2” | 1 |
| 3609927C1 | Bolt, “U” 3/4” x 7” UNF | 2 |
| 416743C2 | Nut, Hexagon Lock Flange 3/4-16UNF, PHC | 4 |

Table 1 Parts Information

WORK INSTRUCTIONS

WARNING! To prevent property damage, personal injury, and / or death, park vehicle on hard flat surface, turn the engine off, set the parking brake, and install wheel chocks to prevent the vehicle from moving in both directions.

WARNING! To prevent property damage, personal injury, and / or death, use extreme caution when lowering or raising the floor jack to allow suspension movement.

WARNING! To prevent personal injury and / or death, always wear safe eye protection when performing vehicle maintenance.

WARNING! To prevent personal injury and / or death, if the vehicle must be raised, do not work under the vehicle supported only by jacks. Jacks can slip or fall over.

WARNING! To prevent property damage, personal injury, and / or death, keep flames or sparks away from vehicle and do not smoke while servicing the vehicle's batteries. Batteries expel explosive gases.

1. Park vehicle on flat surface.
2. Shift transmission into Park or Neutral and set parking brake.
3. Turn ignition to Key OFF position.
4. Install wheel chocks.
5. Using a tape measure, measure front of truck from frame rail to ground on both left-side and right-side.
 - a. If front left-side is lower than right-side by a measurement greater than 3/8 inch, proceed to Step 6.
 - b. If front left-side is lower than right-side by a measurement less than 3/8 inch, proceed to Step 15.

WARNING! To prevent property damage, personal injury, and / or death, use extreme caution when lowering or raising the floor jack to allow suspension movement.

6. Using a floor jack positioned at a safe location on front axle, lift vehicle and secure with 3-foot jack stands on frame rails.
7. Using a floor jack to support axle from falling, remove left-side U-bolts.
8. Lower floor jack supporting front axle to allow enough space between left-side spring and axle to insert spacer.

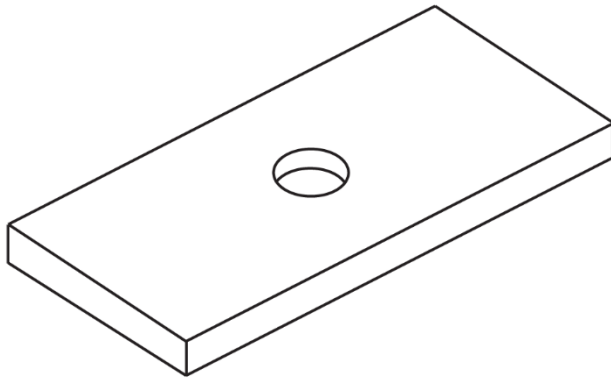

0000435983

Figure 1. Spacer

NOTE: Ensure the lower tabs fit into the hole in the axle and the center pin tab of the spring fits into the spacer.

9. Insert spacer (Figure 1) on left-side with tab pointing down.
10. Raise floor jack to remove any space between spacer, axle and spring.
11. Install new U-bolts.
12. Using a torque wrench, in a diagonal pattern, tighten U-bolts in 50 lb-ft (68 N•m) increments to a final value of 260 – 300 lb-ft (192 – 222 N•m).
13. Lift vehicle and remove jack stands.
14. Lower floor jack and remove from under vehicle.
15. Remove wheel chocks.

LABOR INFORMATION

Operation number must appear on all claims.

| Operation Number | Description | Time |
|------------------|-----------------------------|--------|
| A40-18121-1 | Install Front Spring Spacer | 0.7 hr |

Table 2 Labor Information

WARRANTY CLAIMS

Warranty claim expense is to be charged to Warranty. Claims are to be submitted in the normal manner, making reference to Field Service Campaign 18121.

Section 7 of the Warranty Policy and Procedures Manual contains further information related to the submission and processing of AFC / Recall claims.

As with all claim submissions, items acquired locally must be submitted in the “Other Charges” tab. The cost of any bulk items (such as a bag of cable tie straps, roll of wire, barrel of oil, or tube of silicone) should be prorated for the cost of the individual pieces / amount used during each repair.

To make sure this important improvement is made in a timely manner, all claims for 18121 activity must be submitted by 18 December 2019 or within the normal warranty period for the component, if after 18 December 2019.

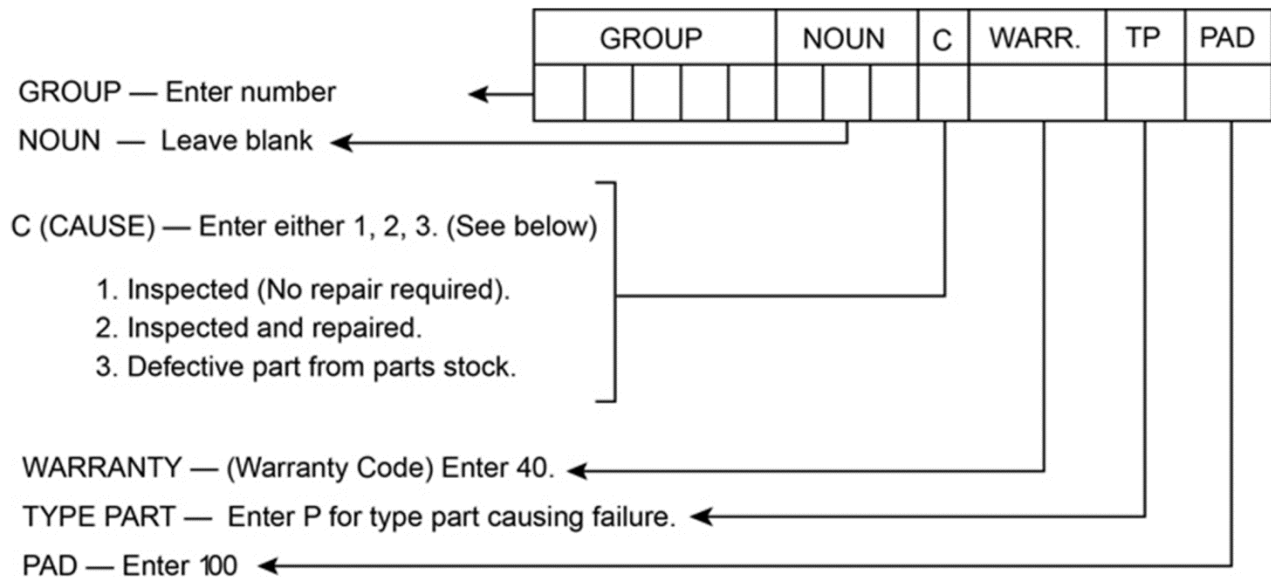

0000047910