

**Noise Symptom - Knocking Noises in the Air Conditioning System: Reworking air conditioning system (SY 170/18)**

Model Line: All **911 Carrera (991)** vehicles excluding GTx models.

Model Year: **As of 2017 up to 2019**

Subject: **Air conditioning**

Symptom: Complaint about "knocking noises" from the underbody area.

Cause: Vibrations from the air-conditioning compressor can be transmitted via the refrigerant lines and holders to the underbody.

Remedial Action: In the event of a customer complaint, attach aluminum butyl damping mats on the underbody as described in the "**Work Procedure**" section.



**Information**

**The following points must be observed in relation to the part numbers listed below and the relevant vehicle (depending on equipment):**

- **Particular/modified components**, whose part numbers are listed accordingly, are **required for the remedial action**.
- **Part number indexes will increase over time**. Before performing repairs, cross reference with PET (Porsche Spare Parts Catalog), for newer parts (higher index).
- **PET must be checked** to determine if additional components are needed.

Parts Info: **971.863.815** ⇒ Insulation for tunnel

Work Procedure: 1 **Preliminary work:**

1.1 Remove cover for rear underbody, see ⇒ *Workshop Manual '519419 Removing and installing cover for rear underbody'*.

2 **Reworking air conditioning system:**

2.1 Cut damping mat (⇒ *Cutting and positioning damping mats -1-*) as shown in the screw point (⇒ *Cutting and positioning damping mats -3-*) and refrigerant line holder (⇒ *Cutting and positioning damping mats -4-*) area leaving 5 mm all the way around (⇒ *Cutting and positioning damping mats -white markings-*).

2.2 Affix damping mats (⇒ *Cutting and positioning damping mats -1 and 2-*) flush on the seam seals (⇒ *Cutting and positioning damping mats -red markings-*).

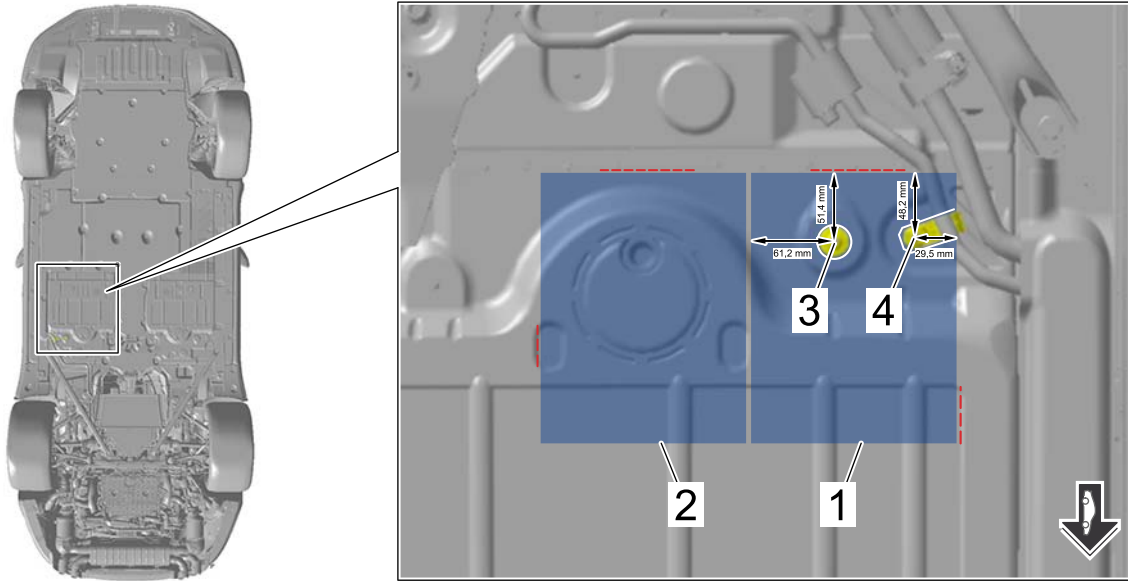

*Cutting and positioning damping mats*

**3 Subsequent work:**

3.1 Install cover for rear underbody, see ⇒ *Workshop Manual '519419 Removing and installing cover for rear underbody'*.

**End** of action required.

Invoicing: The work involved is invoiced under the labor operation:

APOS	Labor operation	I No.
87004900	Reworking air conditioning system	

For invoicing and documentation using PQIS, enter the following coding:

<b>Location (FES5)</b>	87340	Air-conditioning compressor
<b>Damage type (SA4)</b>	2015	creaking

References: ⇒ *Workshop Manual '519419 Removing and installing cover for rear underbody'*

**Important Notice:** Technical Bulletins issued by Porsche Cars North America, Inc. are intended only for use by professional automotive technicians who have attended Porsche service training courses. They are written to inform those technicians of conditions that may occur on some Porsche vehicles, or to provide information that could assist in the proper servicing of a vehicle. Porsche special tools may be necessary in order to perform certain operations identified in these bulletins. Use of tools and procedures other than those Porsche recommends in these bulletins may be detrimental to the safe operation of your vehicle, and may endanger the people working on it. Properly trained Porsche technicians have the equipment, tools, safety instructions, and know-how to do the job properly and safely. Part numbers listed in these bulletins are for reference only. The work procedures updated electronically in the Porsche PIWIS diagnostic and testing device take precedence and, in the event of a discrepancy, the work procedures in the PIWIS Tester are the ones that must be followed.

© 2018 Porsche Cars North America, Inc.