



SERVICE MANUAL INFORMATION

**SB-18-032 CONVENTIONAL DTC P2483
WORKSHOP MANUAL CORRECTION**

**GROUP: SERVICE MANUAL UPDATE
BULLETIN NO: SB-18-032
DATE: 12-18-2018
REF: SB-A-11-090**

SUBJECT VEHICLES: 2018MY-2019MY Conventional Trucks equipped with an J08E.

The following is to inform you of the above caption. This service data should be attached to the relevant pages of the workshop manuals for maintenance and to use for servicing.

OVERVIEW:

Workshop manual correction of DTC P2483 inspection procedure and troubleshooting information.



DTC: P2483

EN01H16F01030F03001185

P2483: Exhaust gas temperature sensor 5 (DPR outlet) - rationality INFORMATION [at Starter switch on]

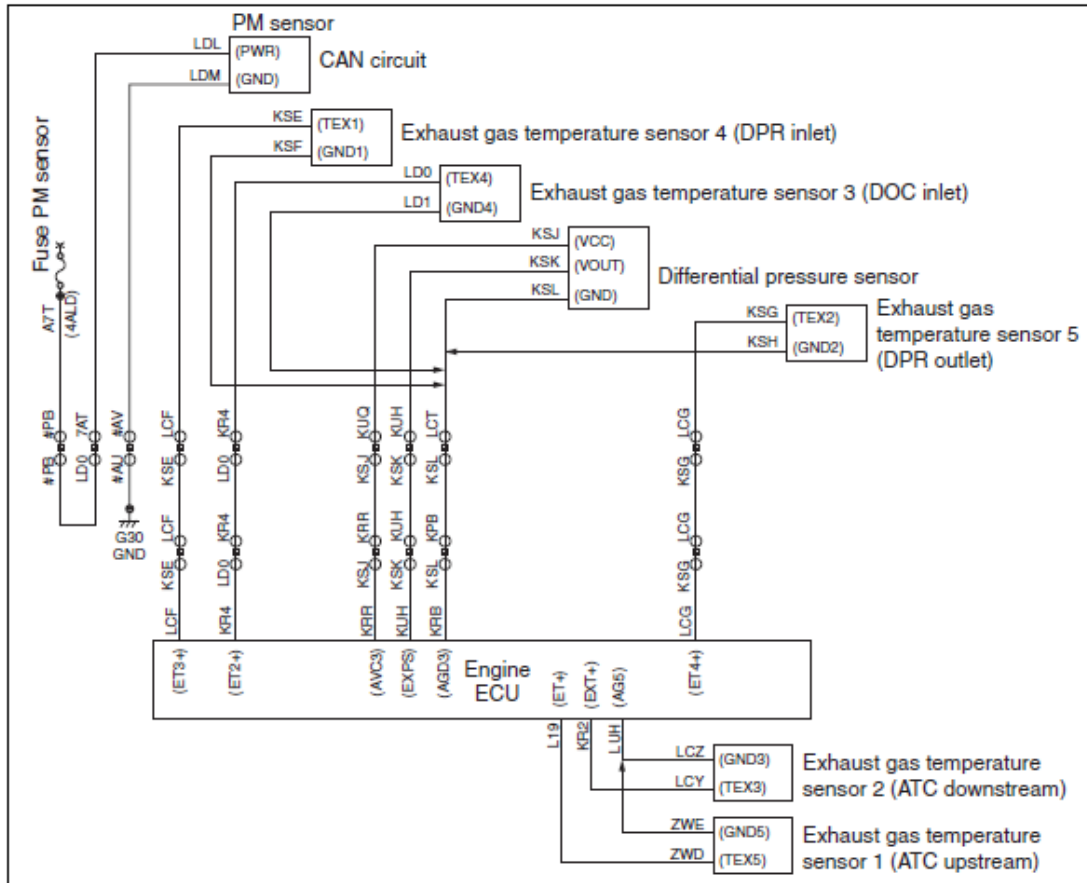

SAPH16F010301368

1. Technical description

- The function of the DPR is to regenerate PM, which raises the exhaust gas temperature.
- The value of the exhaust gas temperature sensor 5 (DPR outlet) is used to control DPR regeneration.

<Description of malfunction>

- The exhaust gas temperature cannot be correctly recognized.

2. DTC set condition**(1) DTC detection condition**

- Battery voltage is in the range of 11 V to 16 V.
- Starter switch ON.
- Engine off.
- Difference between engine coolant temperature and intake temperature is within $\pm 8^{\circ}\text{C}$ ($\pm 14.4^{\circ}\text{F}$) for 8 seconds after the engine start.
- The difference between the engine coolant temperatures before the engine start and at present is 30°C (54°F) or more.
- Engine coolant temperature is at least -10°C (-14°F).
- Intake air temperature is at least -10°C (-14°F).

(2) Judgment criteria

- Difference between exhaust gas temperature sensor 1 (ATC upstream) and exhaust gas temperature sensor 2 (ATC downstream) stays less than $\pm 50^{\circ}\text{C}$ ($\pm 90^{\circ}\text{F}$).
- Difference between exhaust gas temperature sensor 2 (ATC downstream) and exhaust gas temperature sensor 3 (DOC inlet) stays less than $\pm 50^{\circ}\text{C}$ ($\pm 90^{\circ}\text{F}$).
- Difference between exhaust gas temperature sensor 3 (DOC inlet) and exhaust gas temperature sensor 4 (DPR inlet) stays less than $\pm 50^{\circ}\text{C}$ ($\pm 90^{\circ}\text{F}$).
- Difference between exhaust gas temperature sensor 4 (DPR inlet) and exhaust gas temperature sensor 5 (DPR outlet) stays more than $\pm 50^{\circ}\text{C}$ ($\pm 90^{\circ}\text{F}$).
The conditions described above remain for 1 seconds ore more.

3. Reset condition

- Immediately after normal operation is restored.

4. Indication, warning or system control regulation when the DTC is set.

- MIL: ON
- SVS Light: OFF
- Engine output is restricted.

5. Symptoms on the vehicle when the DTC is set**<Symptoms on the vehicle due to backup control (fail safe function)>**

- Engine output is insufficient.

<Symptoms on the vehicle due to malfunction>

- -

6. Pre-inspection work

- Check that the battery voltage is in the normal range.

7. After-inspection work

- Clear all past DTCs.
- Check that no DTC is stored after test drive.

8. Estimated failure factors**Exhaust gas temperature sensor 5 (DPR outlet):**

- Disconnected sensor or sensing unit failure (due to dirt, clogging, damage, etc.)
- Abnormal sensor resistance
- Malfunction of engine ECU sensor power supply

**TRUCKS**

A Toyota Group Company

After the above:

- Battery voltage is in the range of 11 V – 16 V.
- The engine speed remains at 500 r/min or more for 5 seconds or more.
- The difference between the engine coolant temperature and intake air temperature is more than 8°C (14.4°F).
- Exhaust gas flow quantity \geq 500 kg/h.
- Engine speed \geq 1,750 r/min.
- Fuel injection amount \geq 15 mm³/st. cyl.
- Exhaust gas temperature sensor 3 (DOC inlet) is valid.

In addition, the following conditions continue for at least 10 seconds:

- Engine speed variation is within 625 r/min.
- Fuel injection quantity variation is within 625 mm³/st. sec
- Vehicle speed \geq 30 km/h (19 mph).

(2) Judgment criteria

- Difference between the calculated exhaust gas temperature sensor 5 (DPR outlet) and actual exhaust gas temperature sensor 5 (DPR outlet) stays more than 80°C (144°F).
The conditions described above remain for 3 seconds or more.

3. Reset condition

- Immediately after normal operation is restored.

4. Indication, warning or system control regulation when the DTC is set.

- MIL: ON
- SVS Light: OFF
- Engine output is restricted.

5. Symptoms on the vehicle when the DTC is set**<Symptoms on the vehicle due to backup control (fail safe function)>**

- Engine output is insufficient.

<Symptoms on the vehicle due to malfunction>

- –

6. re-inspection work

- Check that the battery voltage is in the normal range.

7. After-inspection work

- Clear all past DTCs.
- Check that no DTC is stored after test drive.

8. Estimated failure factors**Exhaust gas temperature sensor 5 (DPR outlet):**

- Disconnected sensor or sensing unit failure (due to dirt, clogging, damage, etc.)
- Abnormal sensor resistance
- Malfunction of engine ECU sensor power supply

**TRUCKS**

A Toyota Group Company

INSPECTION PROCEDURE: P2483

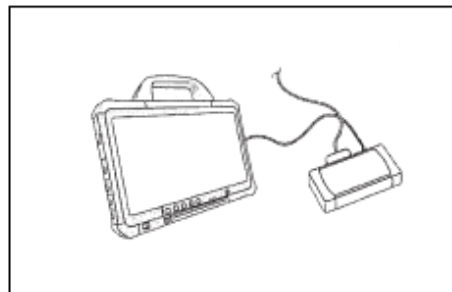
1 Check the DTC detected (Engine ECU) [HINO DX II]

SAPR116F010301370

1. Set the starter switch to the "LOCK" position.
2. Connect the vehicle to HINO DX II .
3. Set the starter switch to the "ON" position.
4. Select [Engine] and check if any DTC other than P2483 has been detected.

Have DTCs other than P2483 been detected?

YES

Go to diagnosis procedure of related DTC.

NO

Go to step 2.

2 Inspect the exhaust gas temperature sensor 5 (DPR outlet) connector

1. Check the connection of the exhaust gas temperature sensor 5 (DPR outlet) connector (Looseness and poor contact).

Was any failure found?

YES

**Connect securely, repair if needed.
Perform "After-inspection work" of INFORMATION section.**

NO

Go to step 3.

3 Inspect the exhaust gas temperature sensor 5 (DPR outlet)

1. Check the installation of the exhaust gas temperature sensor 5 (DPR outlet).
2. Make sure there is no dirt or damage to the exhaust gas temperature sensor 5 (DPR outlet).

Was any failure found?

HINO

TRUCKS

A Toyota Group Company

YES

Clean the exhaust gas temperature sensor 5 (DPR outlet) and install it properly.
If damaged, replace the exhaust gas temperature sensor 5 (DPR outlet).
Perform "After-inspection work" of INFORMATION section.

NO

Go to step 4.

4 Inspect the exhaust gas temperature sensor 5 (DPR outlet) unit

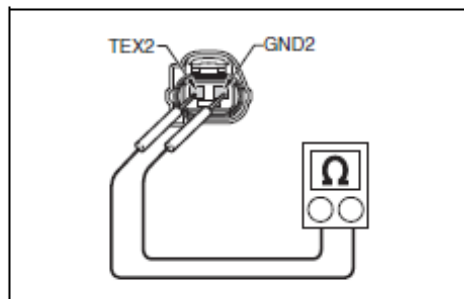

SAPH16F010301371

1. Set the starter switch to the "LOCK" position.
2. Disconnect the exhaust gas temperature sensor 5 (DPR outlet) connector.
3. Use the electrical tester to measure the resistance between the terminals of the exhaust gas temperature sensor 5 (DPR outlet).

Measurement conditions	Tester connections	Standard values
Starter switch: LOCK	Exhaust gas temperature sensor 5 (DPR outlet) TEX2 – GND2	20 °C {68 °F}: 13.7 – 29.8 kΩ 50 °C {122 °F}: 7.13 – 13.7 kΩ 80 °C {176 °F}: 4.1 – 7.13 kΩ

Do the measurements meet the standard value?

YES

Go to step 5.

NO

Replace the exhaust gas temperature sensor 5 (DPR outlet)
Perform "After-inspection work" of INFORMATION section.

HINO

TRUCKS

A Toyota Group Company

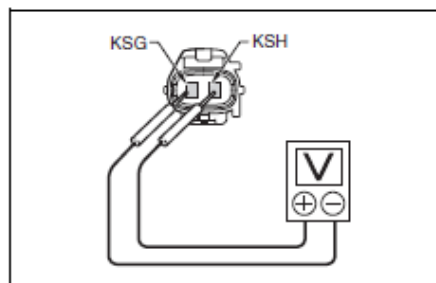
5 Inspect the exhaust gas temperature sensor 5 (DPR outlet) power supply

1. Set the starter switch to the "ON" position.
2. Use the electrical tester to measure the voltage between the terminals of the exhaust gas temperature sensor 5 (DPR outlet) vehicle-side connector.

Measurement conditions	Tester connections	Standard values
Starter switch: ON	Exhaust gas temperature sensor 5 (DPR outlet) vehicle-side connector KSG – KSH	4.5 – 5.5 V

Do the measurements meet the standard value?

YES

NO

Go to step 8.

Go to step 6.

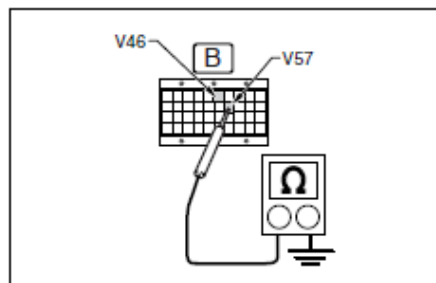
6 Inspect for short-circuit of the exhaust gas temperature sensor 5 (DPR outlet) harness

1. Set the starter switch to the "LOCK" position.
2. Connect the signal check harness to the engine ECU.
3. Use the electrical tester to measure the resistance between the terminals of the engine ECU (signal check harness) and ground.

Measurement conditions	Tester connections	Standard values
Starter switch: LOCK	Engine ECU (signal check harness) AGD3(V46) – Ground ET4+(V57) – Ground	$\infty \Omega$

Do the measurements meet the standard value?

YES

NO

Go to step 7.

Repair or replace the harness.
Perform "After-inspection work" of INFORMATION section.

HINO

TRUCKS

A Toyota Group Company

7 Inspect disconnection of the exhaust gas temperature sensor 5 (DPR outlet) harness

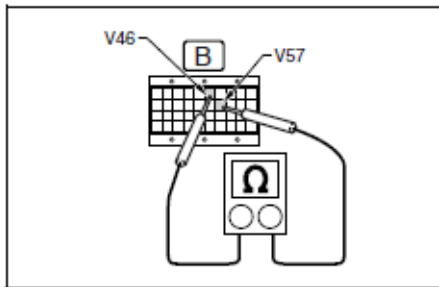

SAPH16F010301374

1. Connect the exhaust gas temperature sensor 5 (DPR outlet) connector.
2. Use the electrical tester to measure the resistance between the terminals of the engine ECU (signal check harness).

Measurement conditions	Tester connections	Standard values
Starter switch: LOCK	Engine ECU (signal check harness) AGD3 (V46) – ET4+ (V57)	20 °C (68 °F): 13.7 – 29.8 kΩ 50 °C (122 °F): 7.13 – 13.7 kΩ 80 °C (176 °F): 4.1 – 7.13 kΩ

Do the measurements meet the standard value?

YES

Go to step 8.

NO

Repair or replace the harness.
Perform "After-inspection work" of INFORMATION section.

8 Check the DTC detected (Engine ECU) 2 [HINO DX II]

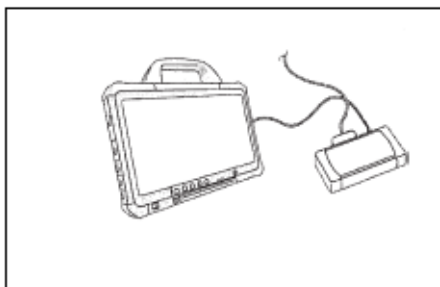

SAPH16F010301375

1. Perform engine warm-up. (engine coolant temperature: 60 °C (140 °F) or more)
2. Stop the engine and set the starter switch to the "LOCK" position.
3. Connect the vehicle to HINO DX II .
4. Set the starter switch to the "ON" position.
5. Select [Engine] and check if P2483 has been detected.

Has DTC P2483 been detected?

YES

Replace the engine ECU.
Perform "After-inspection work" of INFORMATION section.

NO

Procedure completed.
Perform "After-inspection work" of INFORMATION section.