



N276 UPS13118-3BNAS1

# TECHNICAL BULLETIN

21 DEC 2018

© Jaguar Land Rover North America, LLC

NOTE: The information in Technical Bulletins is intended for use by trained, professional Technicians with the knowledge, tools, and equipment required to do the job properly and safely. It informs these Technicians of conditions that may occur on some vehicles, or provides information that could assist in proper vehicle service. The procedures should not be performed by 'do-it-yourselfers'. If you are not a Retailer, do not assume that a condition described affects your vehicle. Contact an authorized Land Rover service facility to determine whether this bulletin applies to a specific vehicle.

## INFORMATION

## SECTION:

303-01

## SUBJECT/CONCERN:

Update Prior to Sale: Center Main Crankshaft Pulley Bolt

## AFFECTED VEHICLE RANGE:

MODEL:	MODEL YEAR:	VIN:	APPLICABILITY:
Discovery (LR)	2019	088985-400585	V6 S/C 3.0L Petrol
Range Rover Velar (LY)	2019	200216-799976	V6 S/C 3.0L Petrol
Range Rover Sport (LW)	2019	421049-839761	V6 S/C 3.0L Petrol /V8 S/C 5.0L Petrol

MODEL:	MODEL YEAR:	VIN:	APPLICABILITY:
Range Rover (LG)	2019	531122-540602	V6 S/C 3.0L Petrol /V8 S/C 5.0L Petrol

## MARKETS:

NORTH AMERICA

## CONDITION SUMMARY:

### SITUATION:

An issue has been identified on certain Land Rover vehicles within the listed Affected Vehicle Range where the center main crankshaft pulley/damper bolt may have been manufactured away from specification.

### ACTION:

Retailers are required to HOLD affected new vehicles that are within your control and refrain from releasing the vehicles for new vehicle sale pending completion of the Diagnostic/Workshop Procedure detailed in this Technical Bulletin. Unsold vehicles should have this performed as part of the Pre-Delivery Inspection (PDI) process but must have it completed prior to vehicle handover to the customer.

This program does not apply to any vehicle already registered and in use, either with the retailer or customer. Any vehicle already in use may continue to be driven and any repair instructions deemed necessary will be communicated through a separate bulletin.

## PARTS:

### NOTE:

Partial quantities of all campaign requirements for LR011952 were shipped to all USA and Canada Retailers on December 20, 2018. Parts orders for the remaining balance of all campaign parts have been placed for all USA and Canada Retailers and will be fulfilled over the next several days.

DESCRIPTION	PART NUMBER/SUNDRY CODE	QUANTITY/VALUE	EXPECTED PERCENTAGE DEMAND
Bolt(s) - Center main crankshaft pulley	LR011952	1	100

## SPECIAL TOOLS:

Refer to TOPIx Workshop Manual/Workshop Procedure for any required special tools.

## WARRANTY:

### NOTE:

Use the Jaguar Land Rover claims submission system to make sure that a vehicle is affected by this program prior to undertaking any rework action.

At the time of confirming a booking for vehicle repair, make sure that all open Recall and Service Actions are identified to make sure the correct parts are available and adequate workshop time is allocated for repairs to be completed at one visit.

Warranty claims must be submitted quoting the Program Code and the relevant Option Code; this will result in payment of the stated time. The SRO and parts information is included for information only. The Option Code(s) that allows for the drive in/drive out allowance may only be claimed if the vehicle is brought back into the workshop for this action alone to be undertaken.

Repair procedures are under constant review and therefore times/prices are subject to change; those quoted here must be taken as guidance only. Use TOPIx to obtain the latest repair time.

This program is valid for a limited time only. Warranty claims with a repair date prior to the December 20, 2019, closure date must be submitted or payment within 30 calendar days of completion of the repair.

PROGRAM CODE	OPTION CODE	DESCRIPTION	SRO	TIME (HOURS)	PART NUMBER/SUNDRY CODE	QUANTITY/VALUE
--------------	-------------	-------------	-----	--------------	-------------------------	----------------

PROGRAM CODE	OPTION CODE	DESCRIPTION	SRO	TIME (HOURS)	PART NUMBER/SUNDRY CODE	QUANTITY/VALUE
N276	A	Discovery, Range Rover Sport, Range Rover Crankshaft pulley bolt(s) - Renew	12.21.89.01	0.9	LR011952	1
N276	B	Discovery, Range Rover Sport, Range Rover Crankshaft pulley bolt(s) - Renew Drive in/drive out	12.21.89.01 02.02.02	0.9 0.2	LR011952 -	1 -
N276	C	Range Rover Velar Crankshaft pulley bolt(s) - Renew Drive in/drive out	12.21.89.01	1.5	LR011952	1
N276	D	Range Rover Velar Crankshaft pulley bolt(s) - Renew Drive in/drive out	12.21.89.01 02.02.02	1.5 0.2	LR011952 -	1 -

Normal Warranty policies and procedures apply.

#### WORKSHOP PROCEDURE:

#### CAUTION:

**The center main crankshaft pulley/damper bolt is left-hand thread.**

#### NOTES:

- Some variation in the illustrations may occur, but the essential information is always correct.
- Some components shown removed for clarity.

1

 NOTE:

**Discovery, Range Rover Sport, Range Rover only.**

Remove the cooling fan and shroud (see TOPIx Workshop Manual section 303-03: Engine Cooling - Cooling Fan and Shroud).

1 Once all tasks are finished, go to Step 3.

2

 NOTE:

**Range Rover Velar only.**

Remove the radiator (see TOPIx Workshop Manual section 303-03: Engine Cooling - Radiator).

1 Once all tasks are finished, go to Step 3.

3

 NOTE:

Do not discard the 2 outer crankshaft pulley bolt(s).

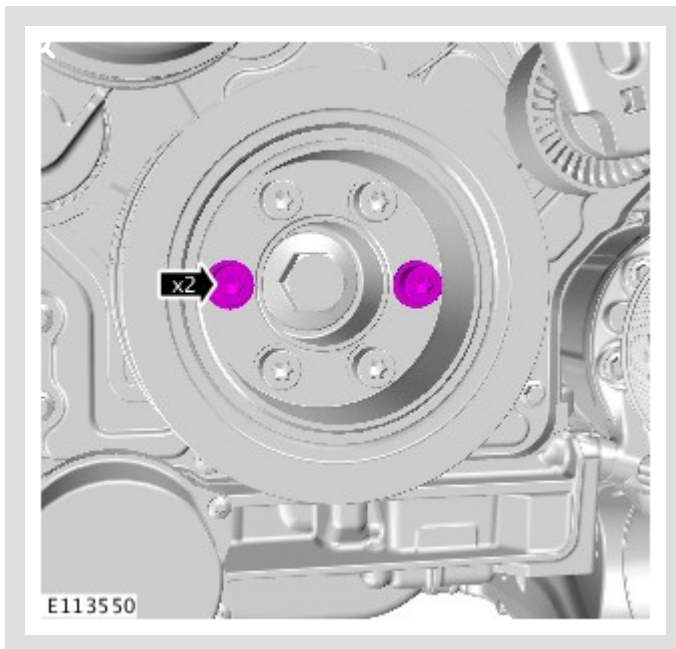

Remove and set to the side **only** the 2 highlighted outer crankshaft pulley bolt(s).

4

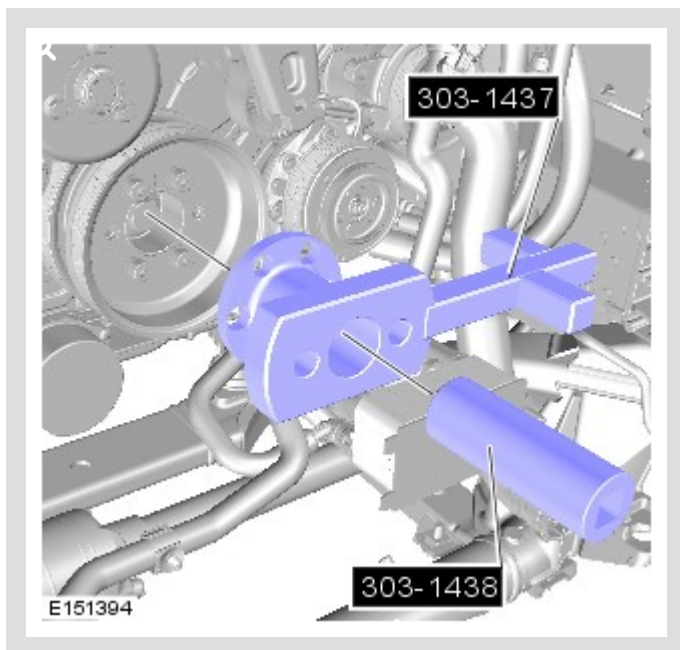

Install the special tools **303-1437** and **303-1438** as shown.

5

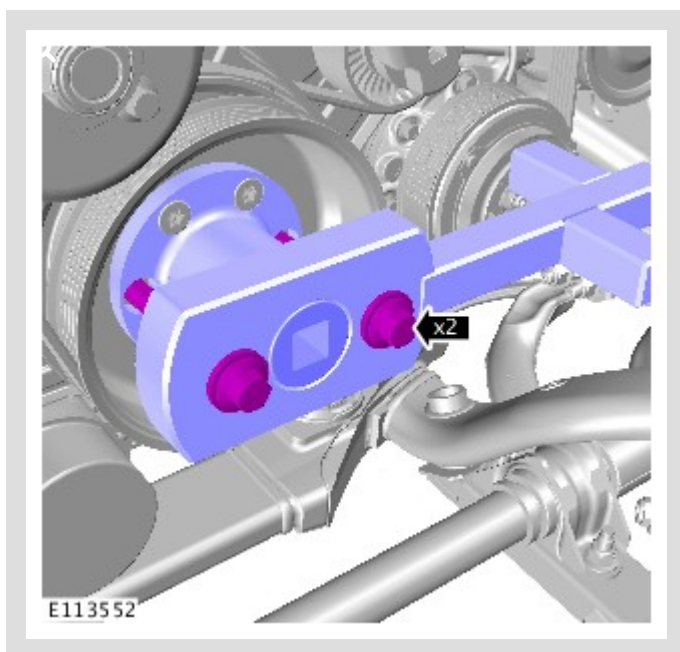

Using the bolt(s) for special tool 303-1437, install the 2 bolt(s) to the crankshaft pulley.

- Torque: **25 Nm**

6

**ⓘ CAUTION:**

Use care when positioning the vehicle stand.

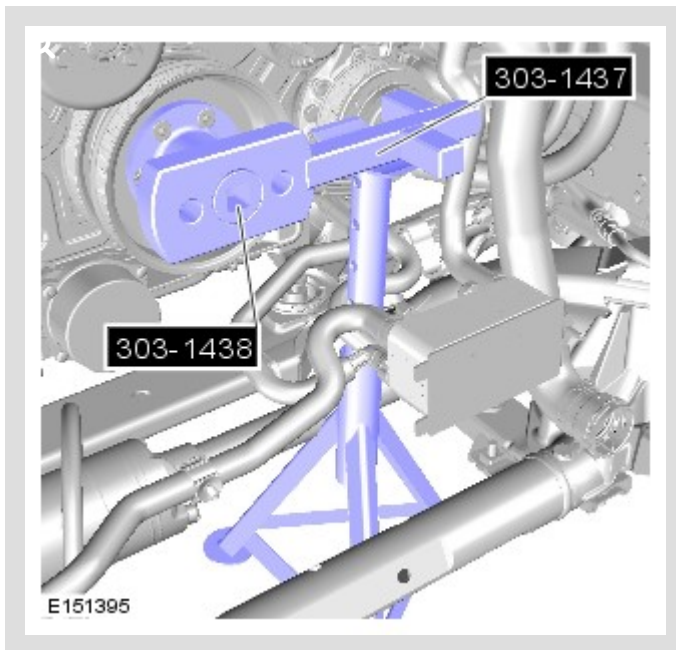

Use a suitable vehicle stand to support the special tools **303-1437** and **303-1438**.

7

**ⓘ CAUTIONS:**

- **The center main crankshaft pulley/damper bolt is left-hand thread.**
- Do not use air tools to remove the center main crankshaft pulley bolt(s).

**⚠ NOTE:**

Loosen the center main crankshaft pulley bolt(s) by hand progressively.

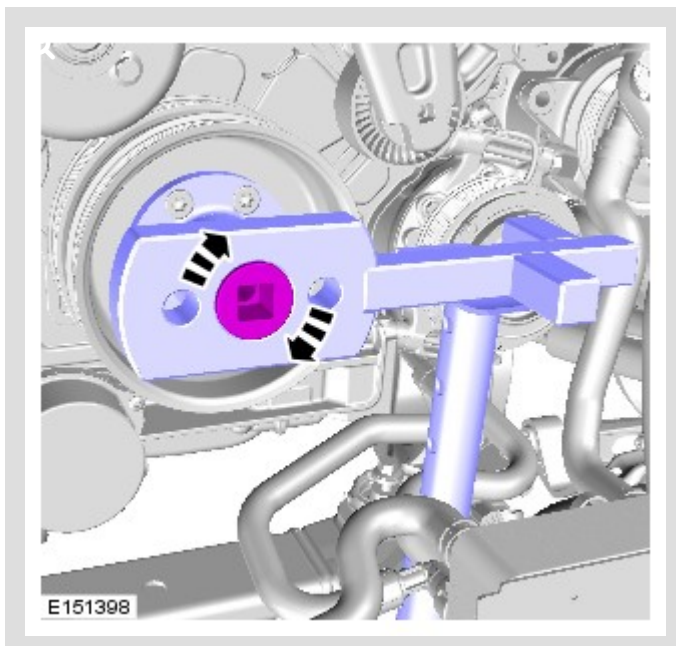

Remove the center main crankshaft pulley bolt(s).

- If the center main crankshaft pulley bolt(s) breaks during removal, **continue to hold the vehicle.**
- If the center main crankshaft pulley bolt(s) does not break during removal, **go to Step 8.**

8

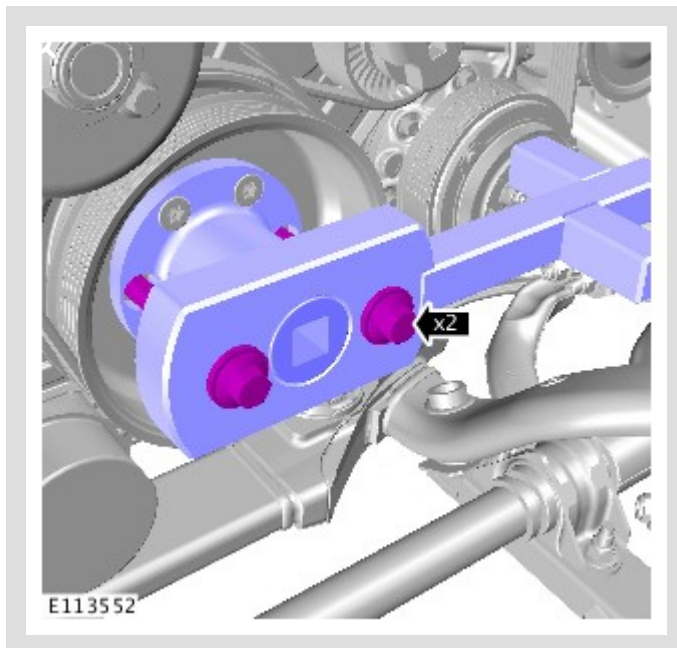

Remove the 2 bolt(s) from special tool **303-1437**.

9

**ⓘ CAUTION:**

Use care when removing the vehicle stand.



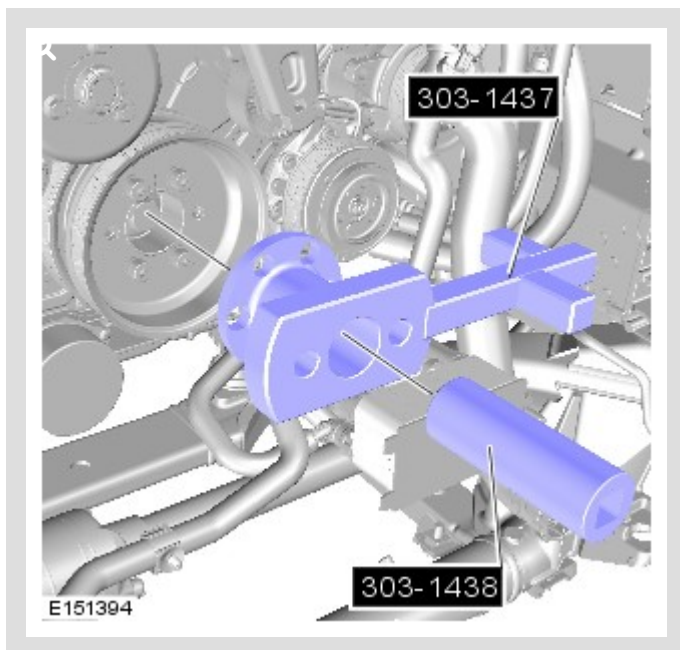

Remove the vehicle stand and special tools **303-1437** and **303-1438**.

10

**ⓘ CAUTION:**

The center main crankshaft pulley/damper bolt is left-hand thread.

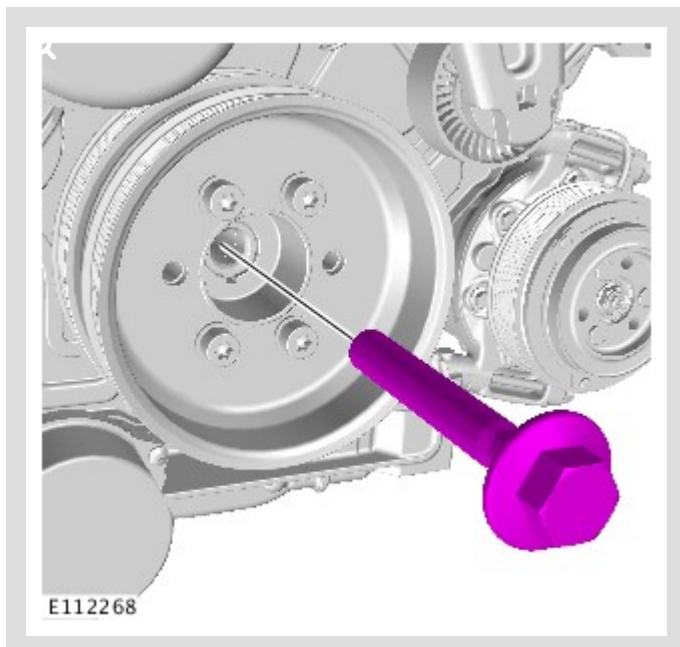

Remove and discard the center main crankshaft pulley bolt(s).

11

**ⓘ CAUTION:**

The center main crankshaft pulley/damper bolt is left-hand thread.

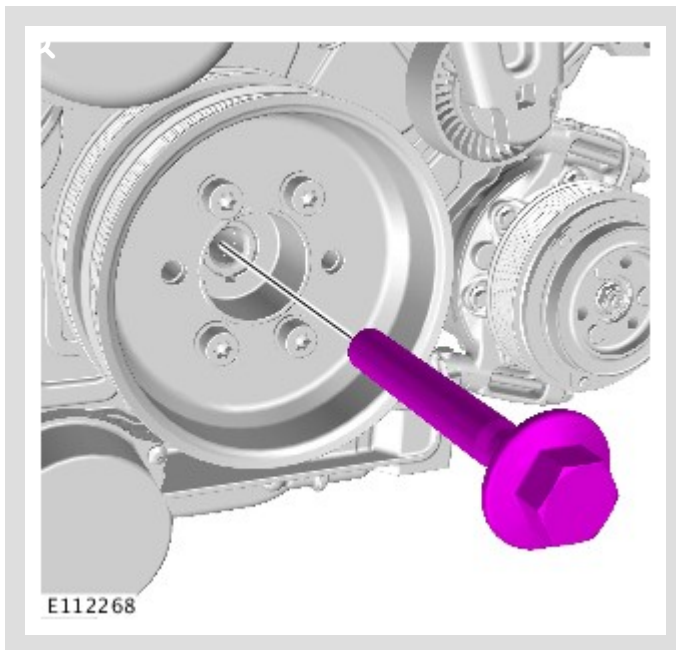

Install the new center main crankshaft pulley bolt(s).

12

**ⓘ CAUTION:**

Use care when positioning the vehicle stand.

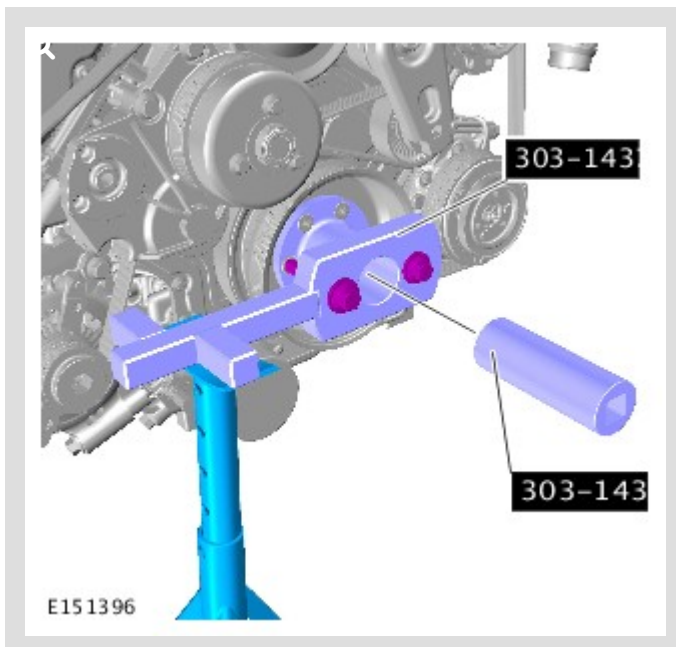

Install the special tools **303-1437** and **303-1438**.

**1** Using the bolt(s) for special tool 303-1437, install the 2 bolt(s) to the crankshaft pulley.

- Torque: **25 Nm**

**2** Use a vehicle stand to support the special tools **303-1437** and **303-1438**.

13

**ⓘ CAUTION:**

The center main crankshaft pulley/damper bolt is left-hand thread.

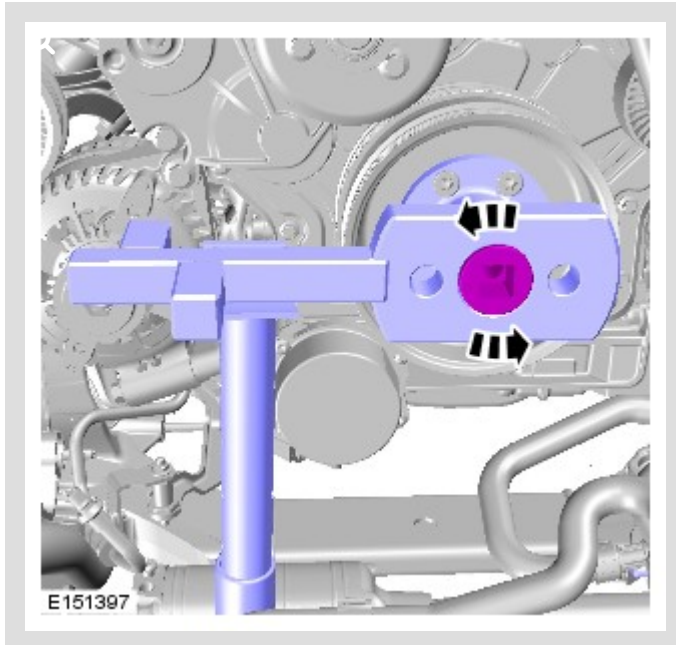

Tighten the center main crankshaft pulley bolt(s) in 2 stages. Make sure that the socket is turned through 270°, not the torque wrench.

- Torque:
  - Stage 1: **200 Nm**
  - Stage 2: **270°**

14

**ⓘ CAUTION:**

Use care when removing the vehicle stand.

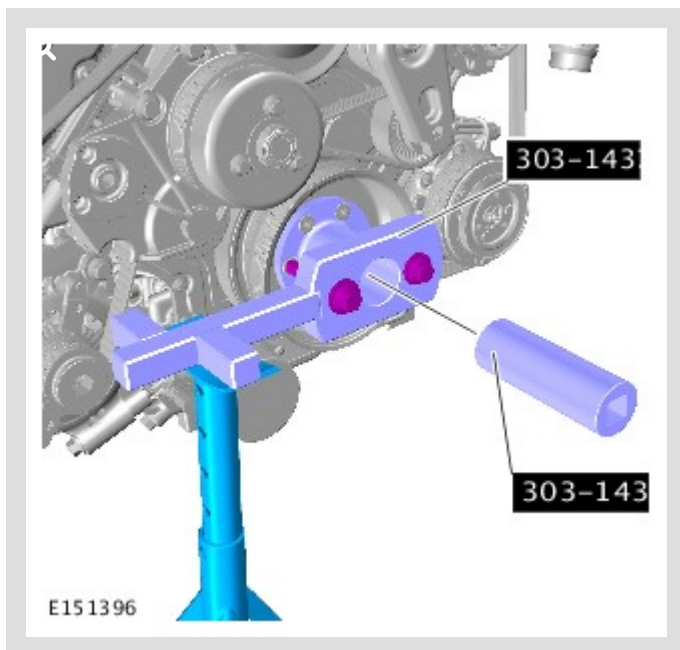

Remove the vehicle stand and special tools **303-1437** and **303-1438**.

15

△ NOTE:

The original M10 bolt(s) can be reused.

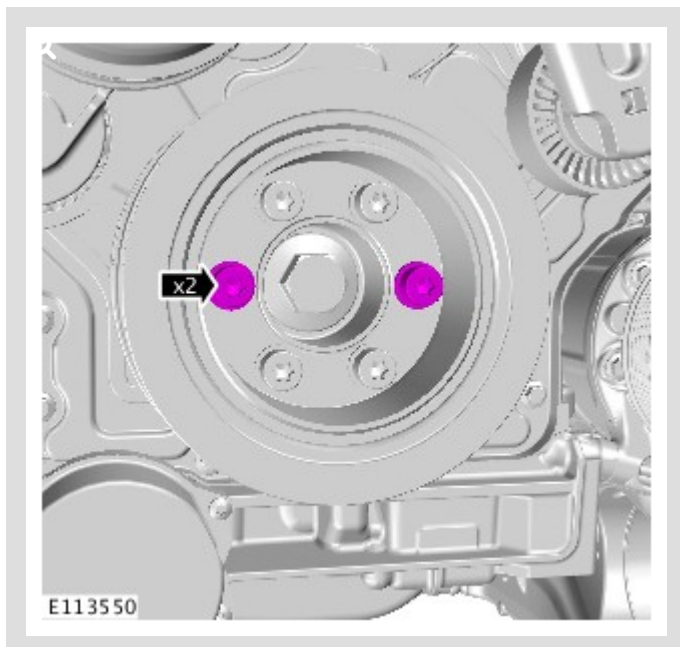

Install the 2 original outer crankshaft pulley bolt(s).

- 1 Clean the original outer crankshaft pulley bolt(s).
- 2 Apply Loctite 270 to the threads.

■ Torque: **65 Nm**

16

 **NOTE:**

**Discovery, Range Rover Sport, Range Rover only.**

Install the cooling fan and shroud (see TOPIx Workshop Manual section 303-03: Engine Cooling - Cooling Fan and Shroud).

- 1 Once all tasks are finished, release the vehicle.

- 
- 17 Install the cooling fan and shroud (see TOPIx Workshop Manual section 303-03: Engine Cooling - Cooling Fan and Shroud).

18

 **NOTE:**

**Range Rover Velar only.**

Install the radiator (see TOPIx Workshop Manual section 303-03: Engine Cooling - Radiator).

- 1 Once all tasks are finished, release the vehicle.