

# Squeak Noise Over Rough Roads/Speed Bumps

**Service Category** Suspension

**Section** Front Suspension

**Market** USA

Toyota Supports  
 ASE Certification 

## Applicability

YEAR(S)	MODEL(S)	ADDITIONAL INFORMATION
2013 - 2018	Avalon, Avalon HV	
2014 - 2017	Camry, Camry HV	

## Introduction

Some 2014 – 2017 model year Camry and Camry HV vehicles and 2013 – 2018 model year Avalon and Avalon HV vehicles may exhibit a squeak noise from the front stabilizer bushings. This condition may be present when traveling over rough roads or speed bumps. Follow the Repair Procedure in this bulletin to address this condition.

## Warranty Information

OP CODE	DESCRIPTION	TIME	OFF	T1	T2
SU1804	R & R Front Stabilizer Bushings and Bracket	1.0	48815-06090 48815-06140 48824-06020	91	99

### APPLICABLE WARRANTY

- This repair is covered under the Toyota Basic Warranty. This warranty is in effect for 36 months or 36,000 miles, whichever occurs first, from the vehicle's in-service date.
- Warranty application is limited to occurrence of the specified condition described in this bulletin.

# Squeak Noise Over Rough Roads/Speed Bumps

## Parts Information

PART NUMBER		MODEL	GRADE	PART NAME	QTY
PREVIOUS	NEW				
48815-06140	48815-33220	Avalon, Avalon HV	All	Bush, Stabilizer, FR	2
		Camry, Camry HV	SE		
48815-06090	48815-33210				XLE, LE
48824-06020	48824-33080	Avalon, Avalon, HV, Camry, Camry HV	All	Bracket, Stabilizer	2

## Repair Procedure

1. Confirm the condition exists.  
Is a squeak noise present from the front when driving over a rough road or speed bumps?
  - **YES** — Continue to step 2.
  - **NO** — This bulletin does NOT apply. Continue diagnosis using the applicable Repair Manual.
2. Apply soapy water to the front stabilizer bushings and recheck for the squeak noise.  
Did the squeak noise change or go away?
  - **YES** — Continue to step 3.
  - **NO** — This bulletin does NOT apply. Continue diagnosis using the applicable Repair Manual.
3. Using an underhoist support stand or equivalent, support the cradle assembly in the location shown.

Figure 1.

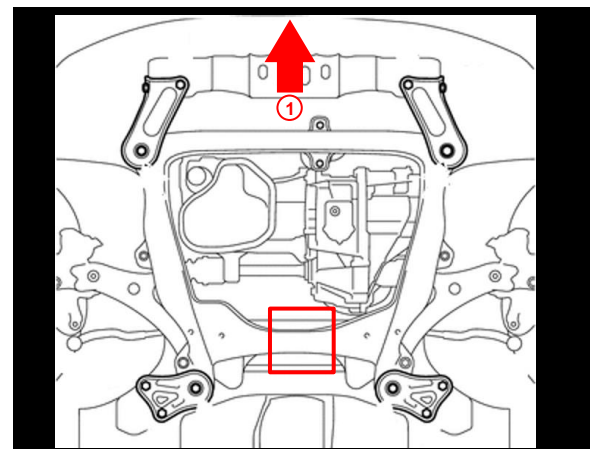

1 Front

## Squeak Noise Over Rough Roads/Speed Bumps

### Repair Procedure (continued)

4. Remove the four nuts from the suspension member brace rear LH and RH.

**Figure 2.**

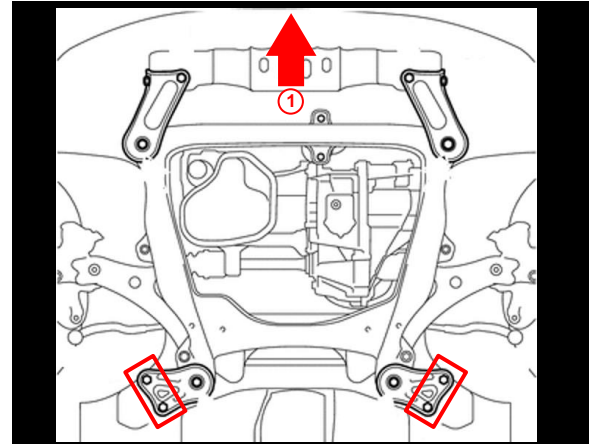

<b>1</b>	<b>Front</b>
----------	--------------

5. Loosen (do NOT remove) the two bolts in the suspension member brace rear LH and RH.

**Figure 3.**

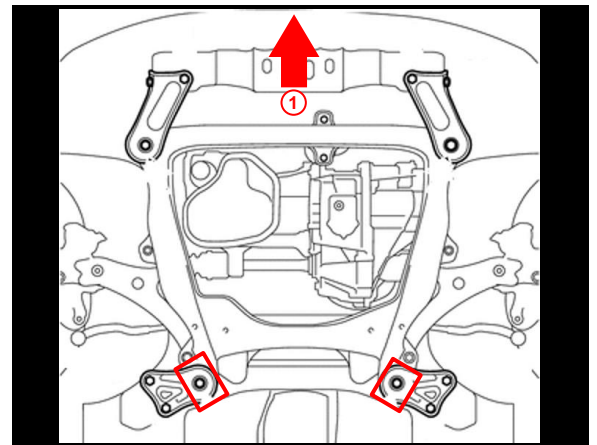

<b>1</b>	<b>Front</b>
----------	--------------

6. Slowly lower the underhoist support stand to gain access to the stabilizer bushings.

**NOTE**

Lowering the underhoist support stand approximately 1 – 1.5 in. will supply sufficient space to remove the bushings.

## Squeak Noise Over Rough Roads/Speed Bumps

### Repair Procedure (continued)

7. Replace the front stabilizer bushings AND the brackets with NEW parts.
  - A. Remove the stabilizer brackets (LH and RH).  
Remove the two bolts and the stabilizer bracket, both LH and RH, from the front frame assembly.

Figure 4. LH Side

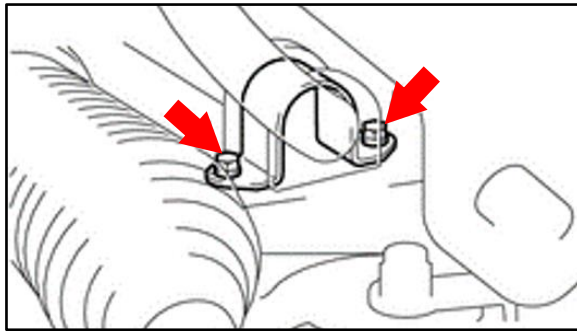
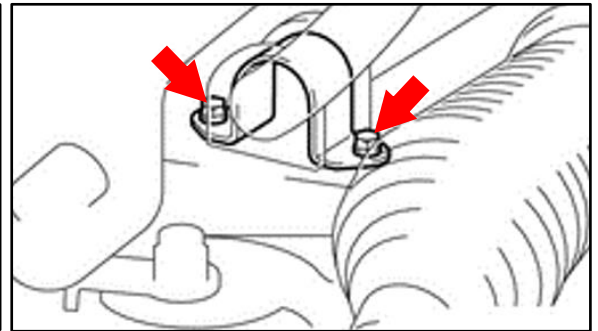

Figure 5. RH Side



- B. Remove both front stabilizer bushings from the front stabilizer bar.
  - C. Install both front stabilizer bushings to the outside of the bushing stopper on the front stabilizer bar.

**NOTE**

Make sure the cutout of the front stabilizer bushing faces the rear side as shown.

Figure 6.

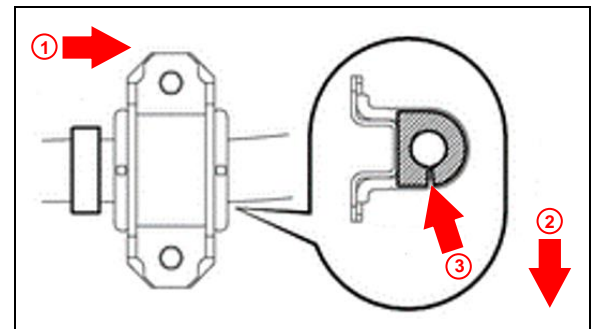

1	Outside
2	Rear
3	Cutout

- D. Install the stabilizer brackets (LH and RH).  
**Torque: 30 N\*m (306 kgf\*cm, 22 ft\*lbf)**
8. Slowly raise the underhoist support stand until the engine cradle is in its original position.

## Squeak Noise Over Rough Roads/Speed Bumps

### Repair Procedure (continued)

9. Torque two bolts in suspension member rear LH and RH.

**Torque: 85 N\*m (867 kgf\*cm, 63 ft\*lbf)**

**Figure 7.**

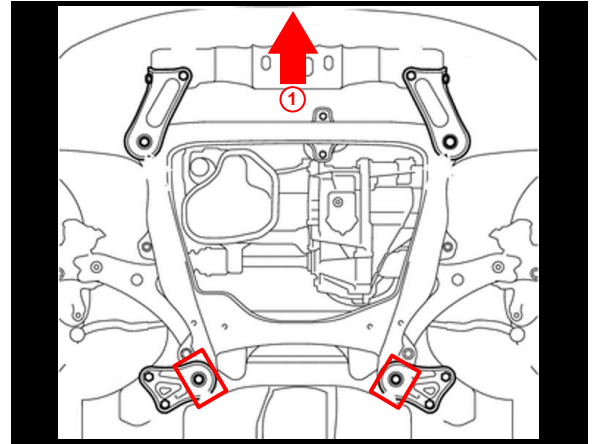

<b>1</b>	<b>Front</b>
----------	--------------

10. Install and torque four nuts on suspension member rear LH and RH.

**Torque: 32 N\*m (329 kgf\*cm, 24 ft\*lbf)**

**Figure 8.**

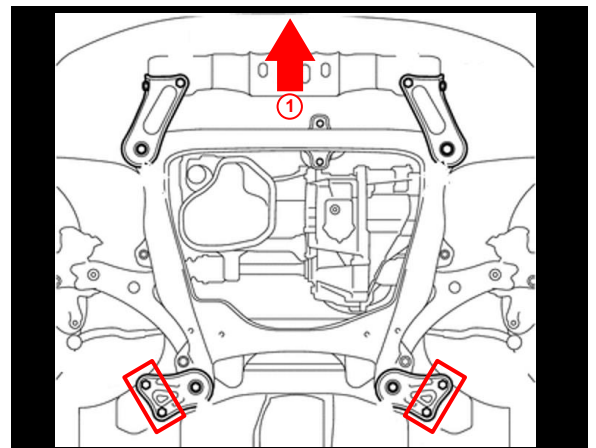

<b>1</b>	<b>Front</b>
----------	--------------

11. Remove the underhoist support stand and confirm the condition no longer exists.