

Classification:

EL18-027

Reference:

ITB18-042

COPYRIGHT© NISSAN NORTH AMERICA, INC.

Date:

November 26, 2018

**2013 M AND 2014-2017 Q70;  
WHISTLE NOISE TRANSMITTED TO CALL RECIPIENT  
WHEN USING BLUETOOTH® HANDS-FREE PHONE FEATURE**

**APPLIED VEHICLES:** 2013 M37 and M56 (Y51)  
2013 M35 Hybrid (Y51)  
2014-2017 Q70 (Y51)  
2014-2017 Q70 Hybrid (Y51)

**IF YOU CONFIRM**

While using the Bluetooth® Hands-Free Phone Feature:

- The call recipient (the person receiving the phone call) hears a whistle noise through their phone's speaker during the call.
- The whistle noise is not heard by the call sender (Infiniti customer) during the call.
- The whistle noise increases when the engine RPM of the call sender's vehicle is raised.

**ACTION**

Repair the related electrical harness wiring at the Telematics Control Unit (TCU).

**IMPORTANT:** The purpose of **ACTION** (above) is to give you a quick idea of the work you will be performing. You **MUST** closely follow the entire **SERVICE PROCEDURE** as it contains information that is essential to successfully completing this repair.

Infiniti Bulletins are intended for use by qualified technicians, not 'do-it-yourselfers'. Qualified technicians are properly trained individuals who have the equipment, tools, safety instruction, and know-how to do a job properly and safely. **NOTE:** If you believe that a described condition may apply to a particular vehicle, DO NOT assume that it does. See your Infiniti retailer to determine if this applies to your vehicle.

## SERVICE PROCEDURE

1. Turn the ignition switch OFF.
2. Remove the instrument lower cover RH.
  - Pull downward and disengage fixing pawl and metal clips.

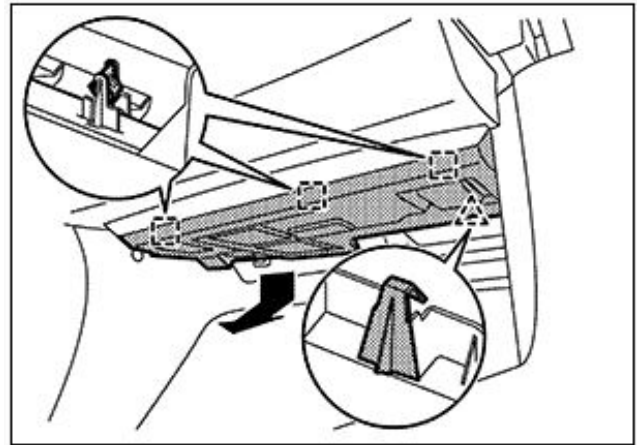
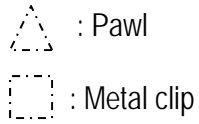

Figure 1

3. Disconnect foot lamp RH harness connector.

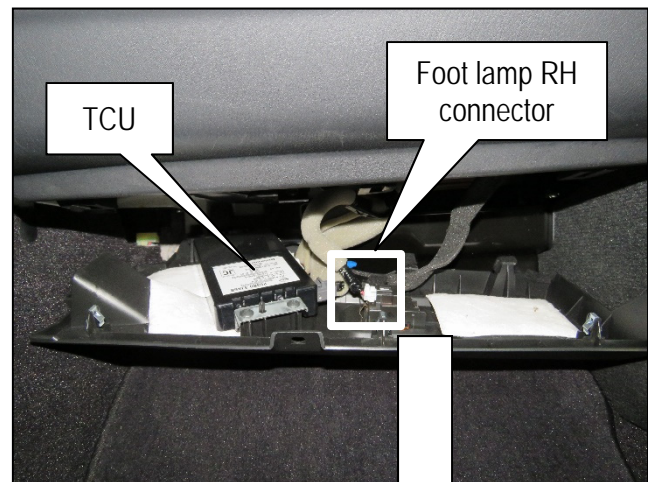

Figure 2

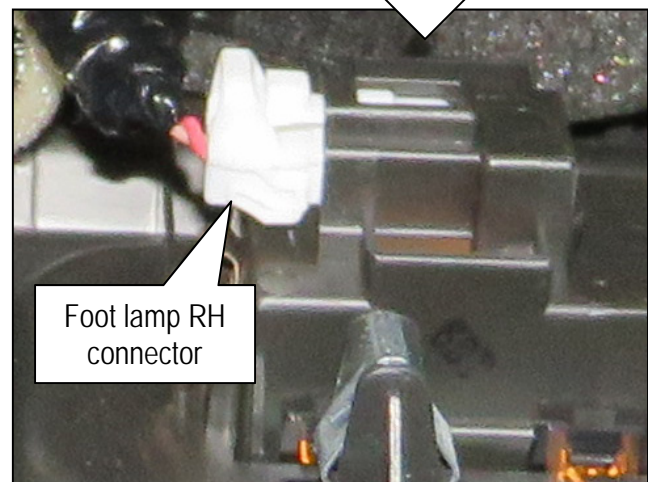

Figure 3

4. Disconnect the TCU's 40 pin connector, M216.

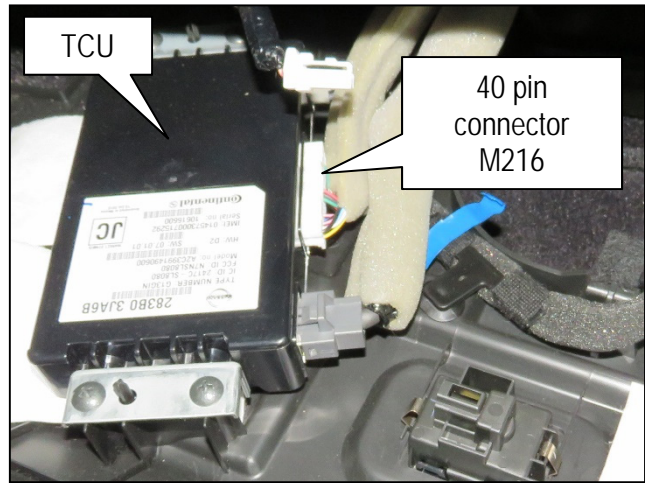

Figure 4

5. Open the foam and corrugated cover to gain access to the harness.
  - Separate 2 inches of the foam and corrugated cover away from connector M216.

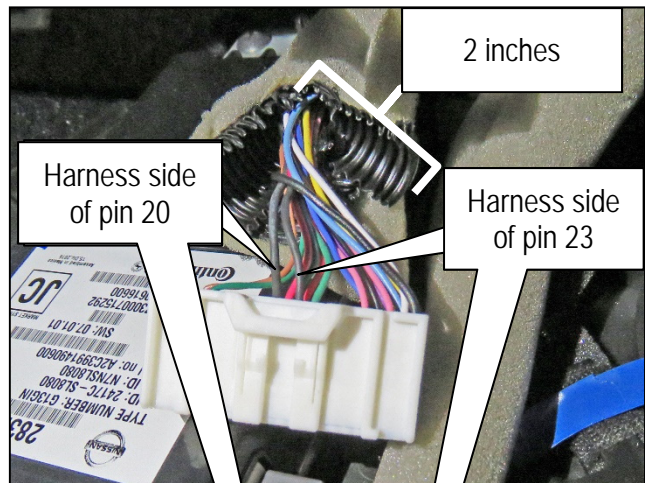

Figure 5

6. Locate black wire in pin 20 and pin 23 in TCU connector M216.

**NOTE:** View is from harness side (rear) of connector M216.

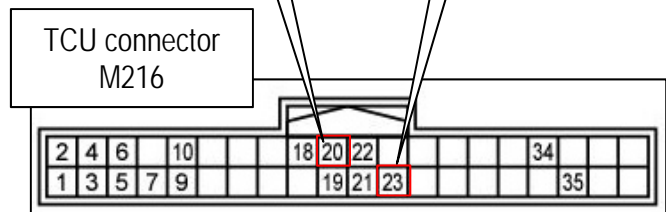

Figure 6

7. Measure 1 inch from M216 and cut both black wires going ONLY to pins 20 and 23.

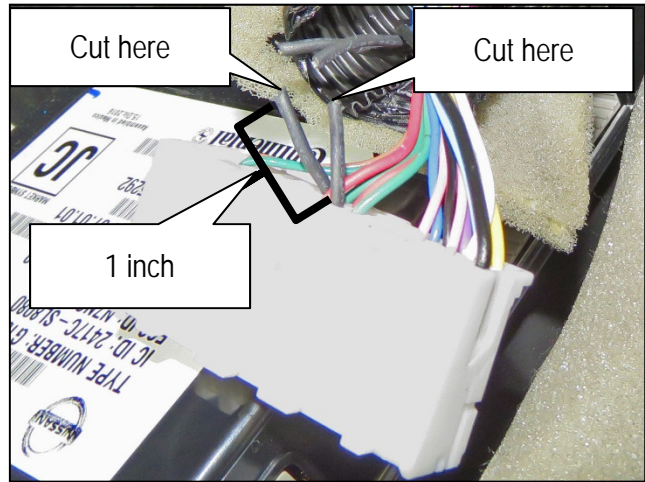

Figure 7

8. Strip ½ inch of insulation from the harness side of both wires.

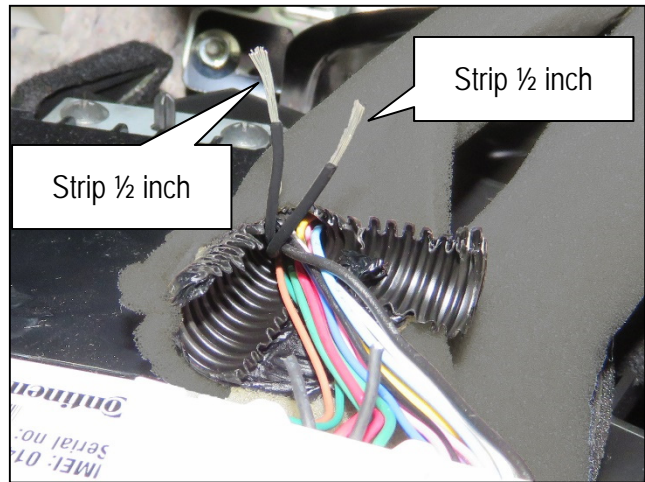

Figure 8

9. Twist the stripped pair of wires together.

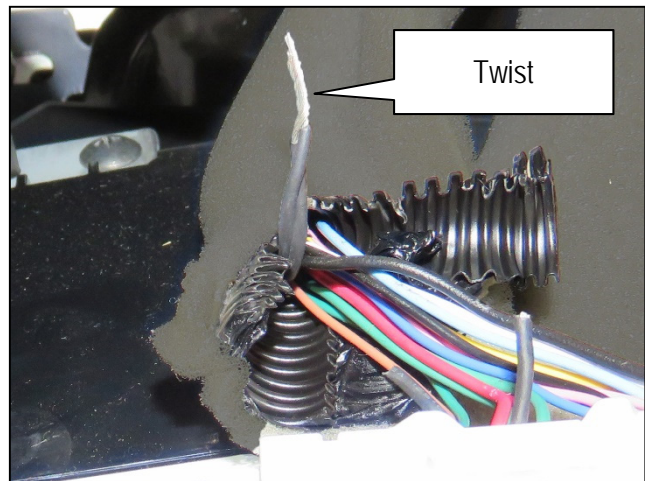

Figure 9

10. Install a Solder Sleeve Connector onto the twisted wire pair.

- Solder Sleeve Connector is listed in the **PARTS INFORMATION** section of this bulletin.

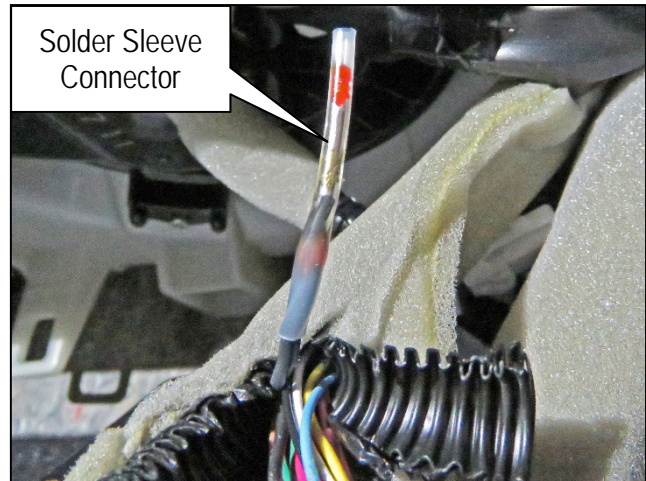

Figure 10

### Solder Sleeve Connector Instructions

11. Slide a Solder Sleeve Connector over the stripped and twisted pair of wires.

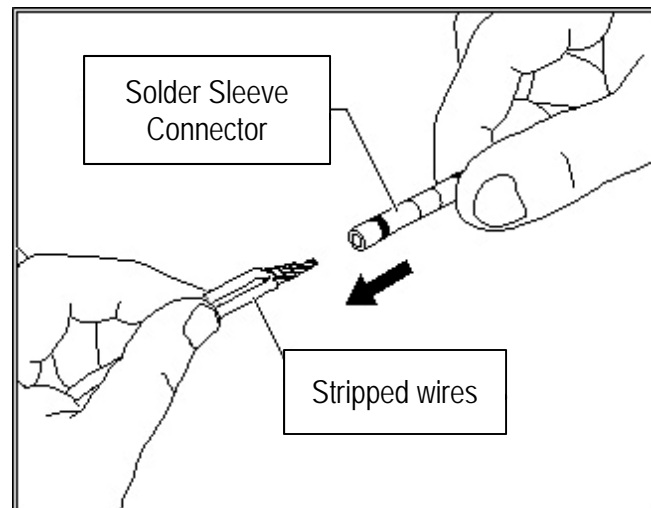

Figure 11

12. Position the Solder Sleeve Connector so that the solder ring (in the Solder Sleeve Connector) is centered around the exposed twisted wire area.

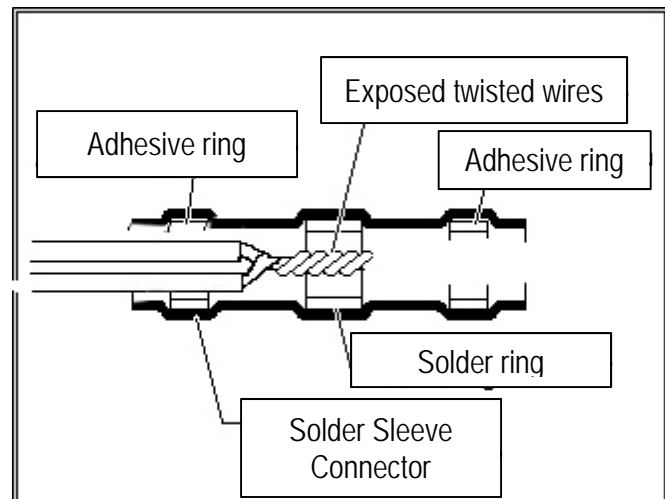

Figure 12

13. Use the special Flameless Heat Gun—J-46538 to heat the Solder Sleeve Connector.

This operation will:

- Melt the solder (silver ring inside the Solder Sleeve Connector) into the exposed twisted wire area.
- Melt the sealant (red rings inside Solder Sleeve Connector) onto the wires.
- Shrink the plastic sleeve onto the wires.

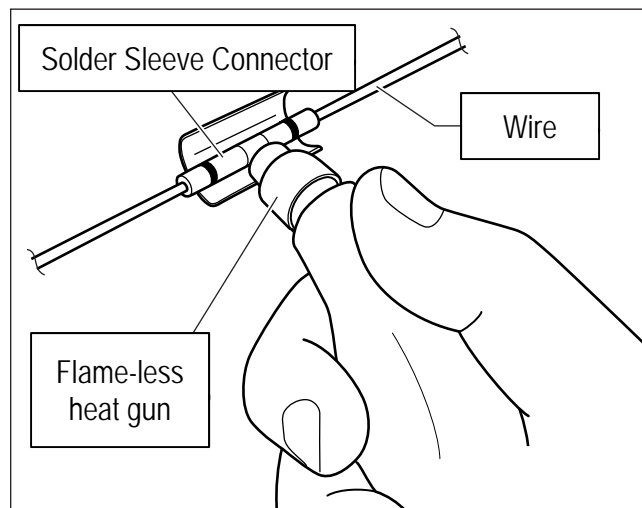

Figure 13

**NOTE:** Tool J-46538 can be purchased from TECH-MATE at 1-800-662-2001.

**Important Soldering Tips:**

- Position the Solder Sleeve Connector in the middle of the heat shield (of the Heat Gun).
- Start heating the Solder Sleeve Connector from the center and move back and forth (side to side) and around to allow even distribution of the heat to the entire Solder Sleeve Connector.
- Make sure the solder completely flows into the exposed twisted wires and the adhesive properly seals the wire insulation to the Solder Sleeve Connector sleeve. Stop applying the heat immediately after this happens.

**WARNING:**

- The Flame-Less Heat Gun and the Solder Sleeve Connector becomes HOT during the soldering process.
- Allow the Gun and Solder Sleeve Connector to cool down before handling them.

**CAUTION:** Be careful not to damage the Solder Sleeve Connector or wires with the heat gun:

- Do NOT apply heat for more than about 40 seconds.
- Do NOT overheat the Solder Sleeve Connector or wires (i.e., severe darkening of Solder Sleeve Connector or wire insulation).

14. Individually tape the 2 cut wires coming out of connector M216.

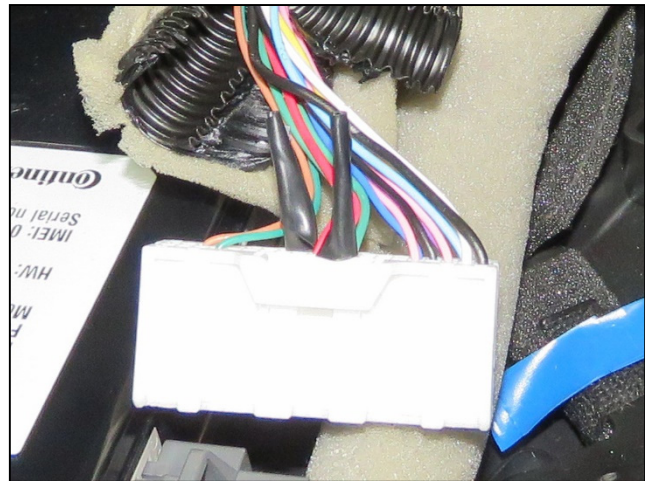

Figure 14

15. Fold the Solder Sleeve Connector up towards the harness.

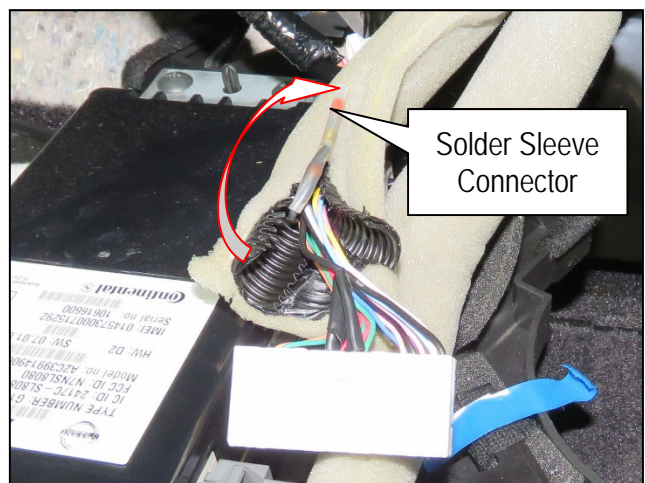

Figure 15

16. Tape the Solder Sleeve Connector, corrugated cover, and foam back onto the harness.

- Use 3M/Scotch Professional Grade Vinyl Super 88 Electrical Tape (3/4" wide) or equivalent.



Figure 16

17. Reconnect connector M216 to the TCU.

18. Reconnect foot lamp RH harness connector.

19. Install the instrument lower cover RH.

- Push upward to engage fixing pawl and metal clips.

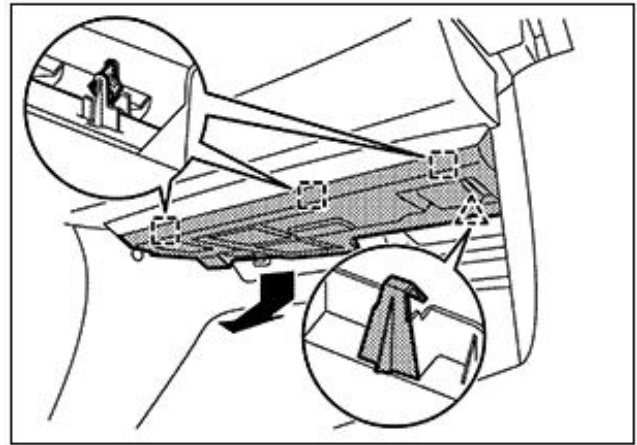
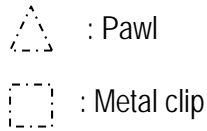

Figure 17

#### PARTS INFORMATION

DESCRIPTION	PART NUMBER	QUANTITY
Terminal – Joint (Solder Sleeve Connector Connector)	24361 – 7990A	1
Electrical Tape	3M/Scotch Professional Grade Vinyl Super 88 Electrical Tape ( 3/4" wide) or equivalent (1)	Shop Supply

(1) This item is available at many local auto supply and hardware stores.

#### CLAIMS INFORMATION

Submit a Primary Part (PP) type line claim using the following claims coding:

DESCRIPTION	PFP	OP CODE	SYM	DIA	FRT
Repair TCU Harness	23461-7990A	RX6XAA	ZE	32	0.3

#### AMENDMENT HISTORY

PUBLISHED DATE	REFERENCE	DESCRIPTION
November 26, 2018	ITB18-042	Original bulletin published