

| | | |
|--------------------------|---|---------------------------|
| TSIB 18-01 Rev. A | | September 28, 2018 |
| TO: | All Operators | |
| TITLE: | Inspect and Reroute, as required, L9N CCV Hose | |
| APPLICABILITY: | All New Flyer L9N CNG Xcelsior Buses built prior to 18-May-2018 | |

New Flyer has observed some instances where the crankcase vent (CCV) filter blow-by gas outlet hose can droop from its originally installed location due to things such as maintenance of other components in the area of the hose. Cummins requires that the CCV filter blow-by gas outlet hose has a slope up from the engine to the CCV filter to prevent moisture accumulation. In four known cases drooping of the hose has allowed moisture to accumulate in the line and freeze blocking release of crankcase pressure. This pressure buildup may cause the front engine cover to bulge out and rub against the engine crankshaft pulley.

This issue may appear on any New Flyer L9N CNG Xcelsior Buses built prior to 18-May-2018.

1. Inspect the routing of the crankcase vent (CCV) filter blow-by gas outlet hose, see Figure 1. Ensure the hose is sloping continuously up from engine to CCV filter without any sharp bends or dips and is routed in such a way that liquid will not accumulate. The hose may need to be adjusted by relocating the hose support p-clips. See Figures 2 and 3.

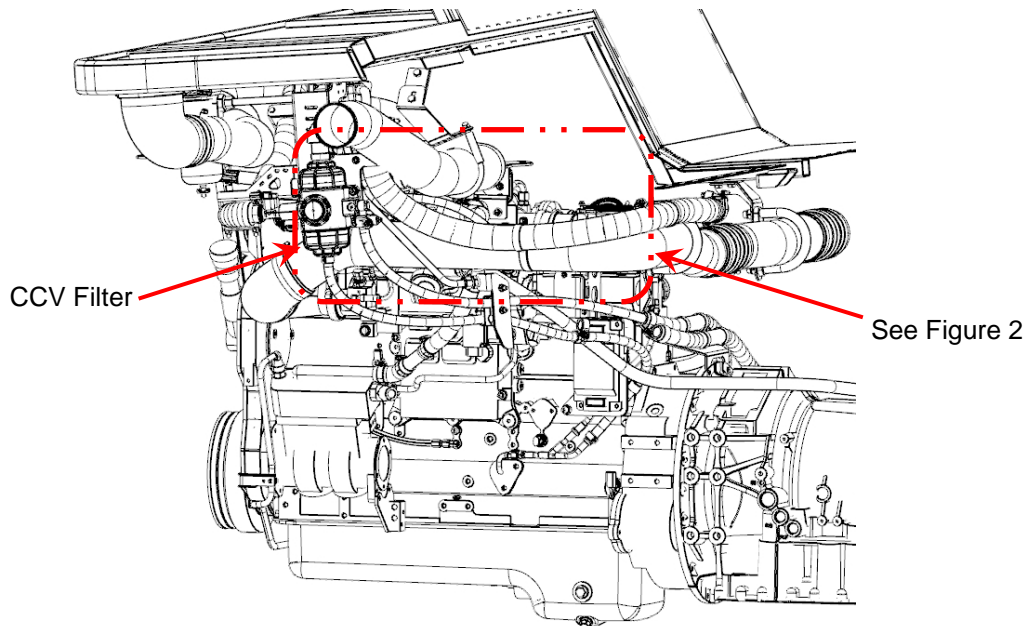

Figure 1: Crankcase Vent Filter Hose Location



NEW FLYER

2. If the CCV hose has a droop exceeding $\frac{3}{4}$ inch, as shown in Figure 2, relocate the existing p-clips securing the hose from the CAC tube to the alternator air intake tube. See Figure 3.

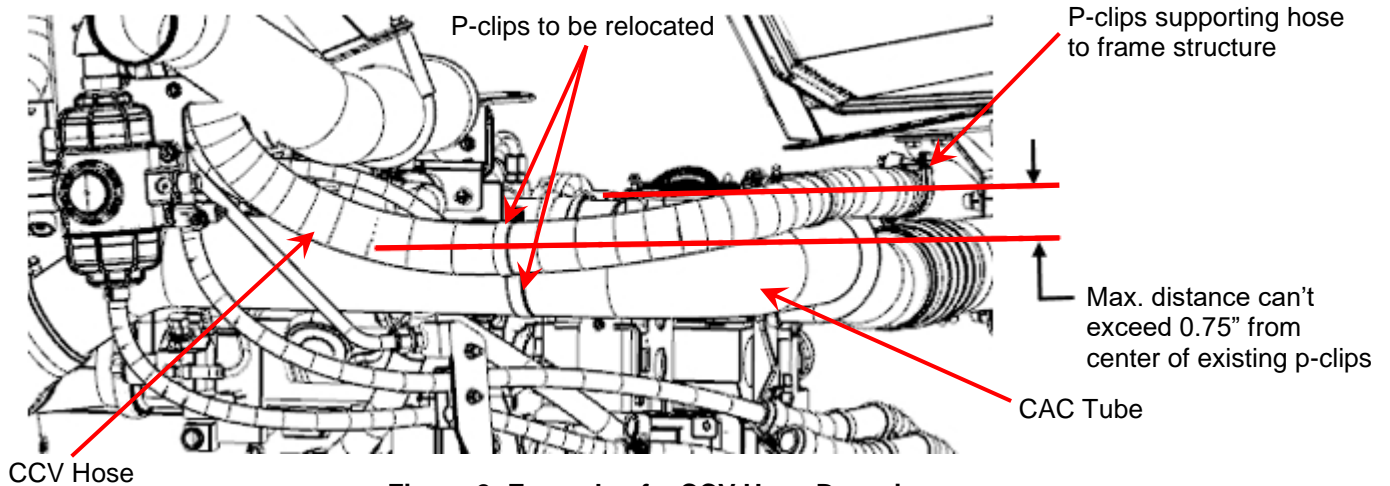

Figure 2: Example of a CCV Hose Drooping

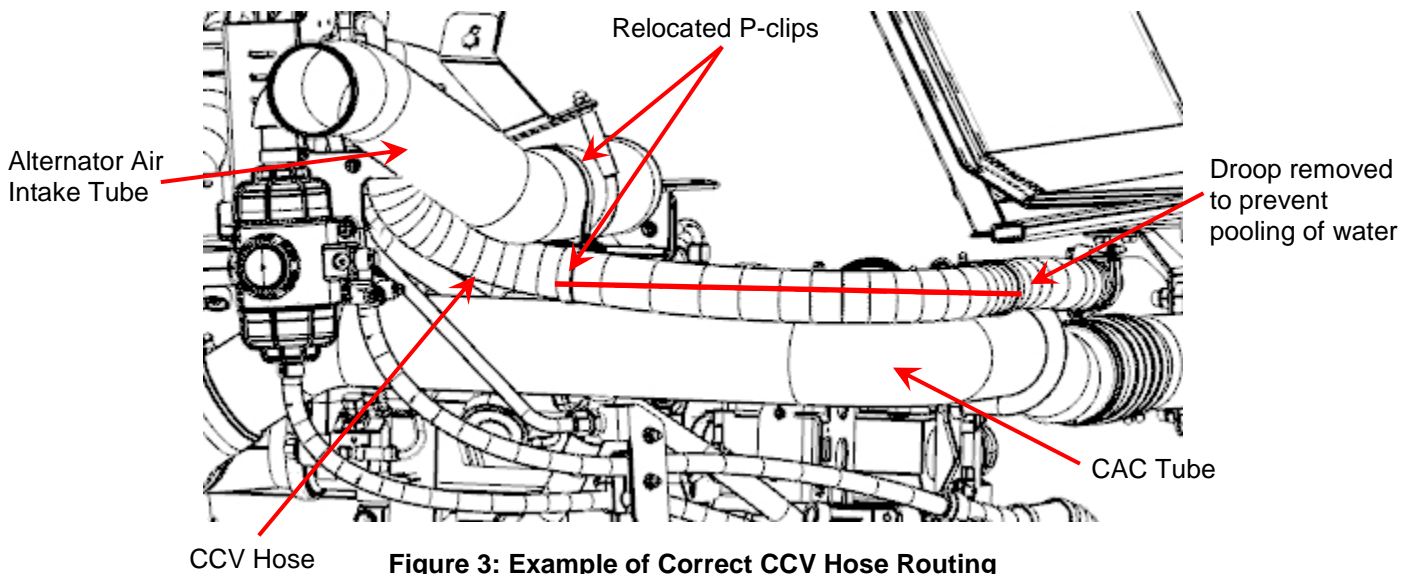

Figure 3: Example of Correct CCV Hose Routing

Direct all inquiries regarding this bulletin to:

Ted Kosokowsky
Technical Service Manager
New Flyer Service Organization
Phone: (204) 224-6859
Email: Ted_Kosokowsky@newflyer.com