



LTB01250NAS1

TECHNICAL BULLETIN

19 NOV 2018

© Jaguar Land Rover North America, LLC

NOTE: The information in Technical Bulletins is intended for use by trained, professional Technicians with the knowledge, tools, and equipment required to do the job properly and safely. It informs these Technicians of conditions that may occur on some vehicles, or provides information that could assist in proper vehicle service. The procedures should not be performed by 'do-it-yourselfers'. If you are not a Retailer, do not assume that a condition described affects your vehicle. Contact an authorized Land Rover service facility to determine whether this bulletin applies to a specific vehicle.

INFORMATION

SECTION:

501-00

SUBJECT/CONCERN:

Rear Spoiler-to-Right D-Pillar Gap Too Tight

AFFECTED VEHICLE RANGE:

MODEL:	MODEL YEAR:	VIN:
Discovery Sport (LC)	2018	748005-778617

MARKETS:

NORTH AMERICA

CONDITION SUMMARY:**SITUATION:**

The rear spoiler gap to the right D-pillar may be too tight or may clash with the right outer D-pillar.

CAUSE:

This may be caused by an incorrect rear spoiler tolerance.

ACTION:

Should a customer express this concern, follow the Inspection Procedure, and if necessary Workshop Procedure, below.

PARTS:

PART NUMBER	DESCRIPTION	QUANTITY
RYH500310	Washer nut(s)	1
LR123708	Adjustable stud(s)	1

TOOLS:

Refer to Workshop Manual for any required special tools.

WARRANTY:**NOTES:**

- Repair procedures are under constant review, and therefore times are subject to change; those quoted here must be taken as guidance only. Always refer to JLR claims submission system to obtain the latest repair time.

- The JLR Claims Submission System requires the use of causal part numbers. Labor only claims must show the causal part number with a quantity of zero.

DESCRIPTION	SRO	TIME (HOURS)	CONDITION CODE	CAUSAL PART
Rear spoiler - Inspection - No further action	05.10.10	0.1	07	LR074674
Rear spoiler - Modification	76.10.89.05	0.2	07	LR074674

△ NOTE:

Normal Warranty procedures apply.

INSPECTION PROCEDURE:

1

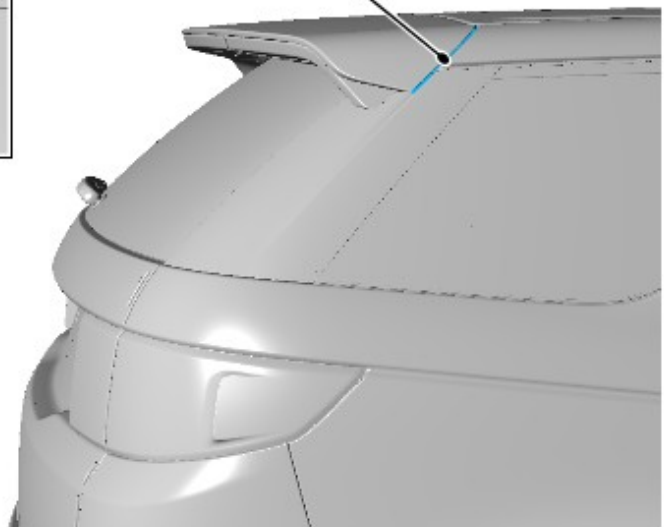
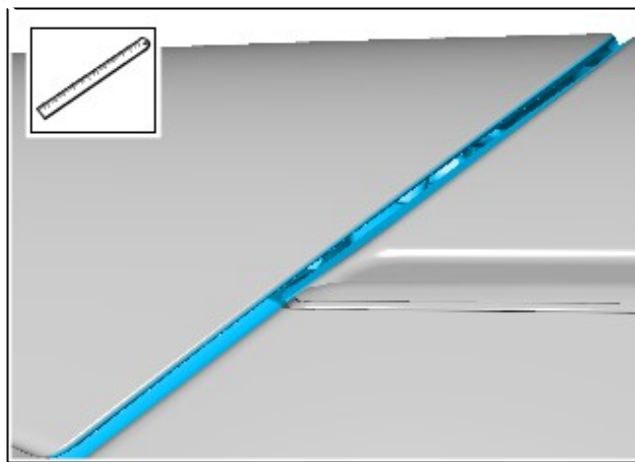

E235 708

Use a suitable tool to measure and record the gap between the rear spoiler and the right outer D-pillar.

- If the gap is 2.5mm-5.5mm (in specification), do not continue with this Technical Bulletin.
- If the gap is less than 2.5mm or greater than 5.5mm (out of specification), go to the Workshop Procedure below.

WORKSHOP PROCEDURE:

1 Open the tailgate.

2

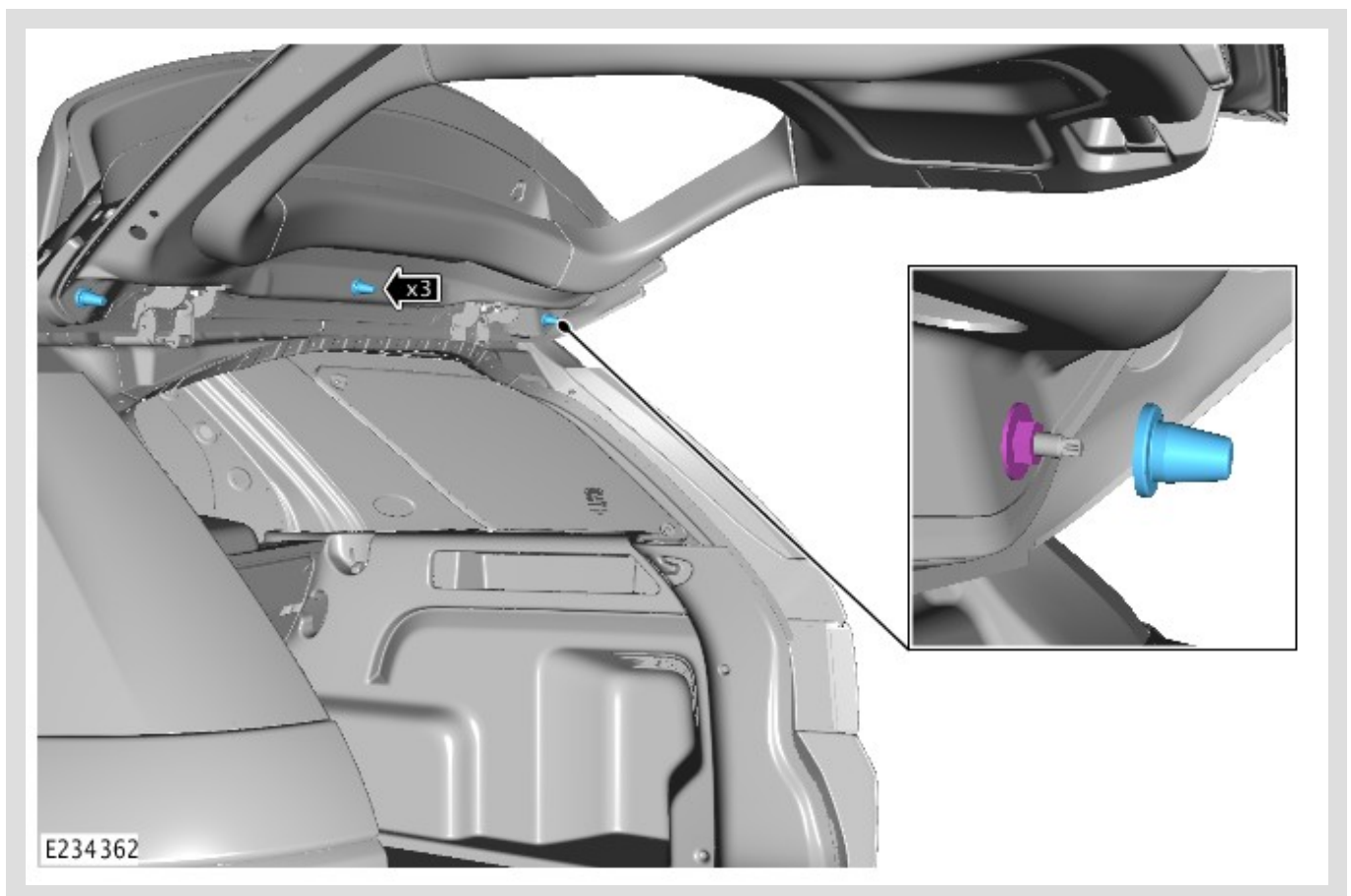

Remove the 3 rear spoiler fastener covers and fasteners.

- Torque: **10 Nm**

3

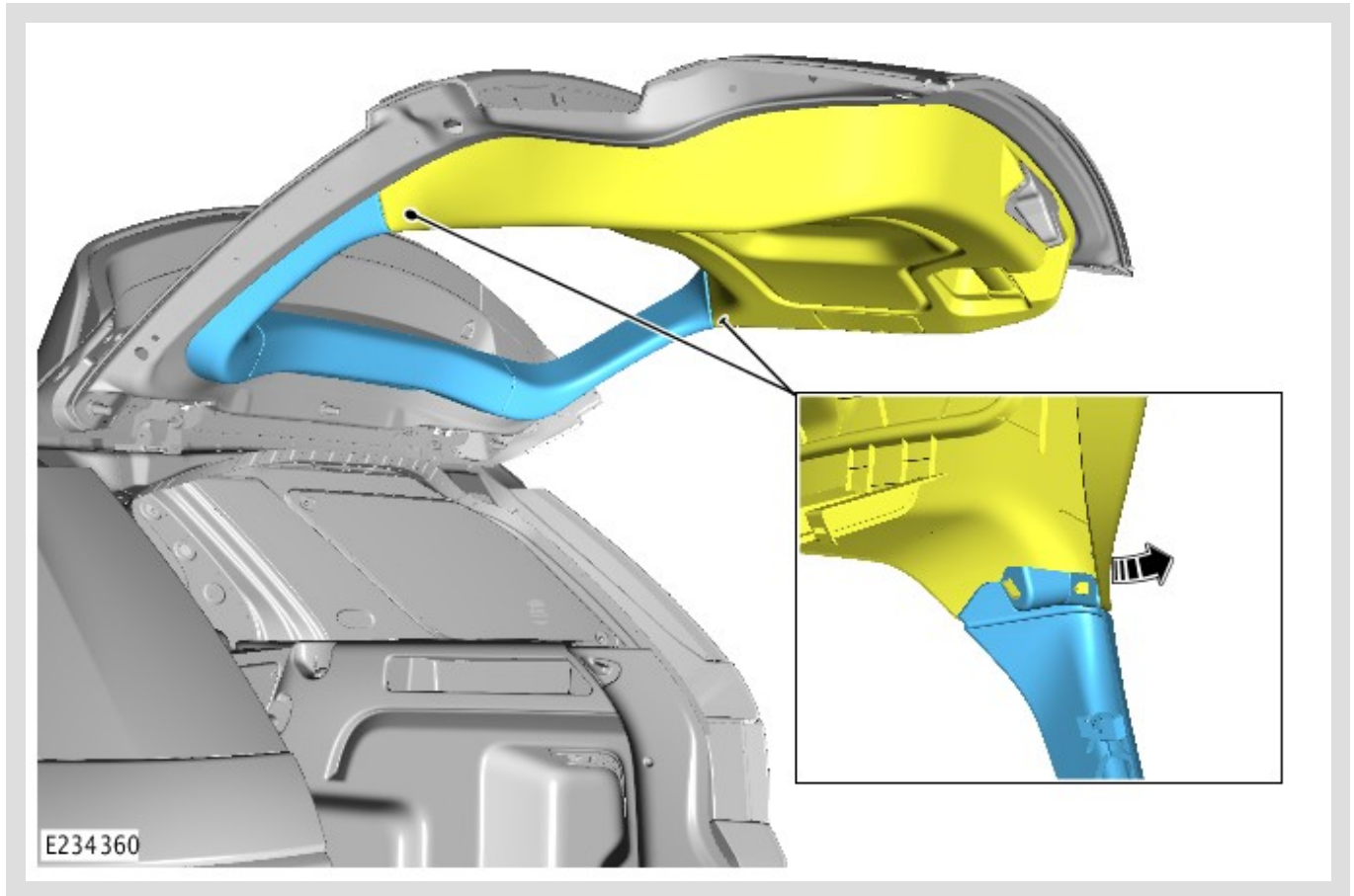

Remove the tailgate interior upper trim panels.

4

 **NOTE:**

Retain the rear spoiler left fastener.

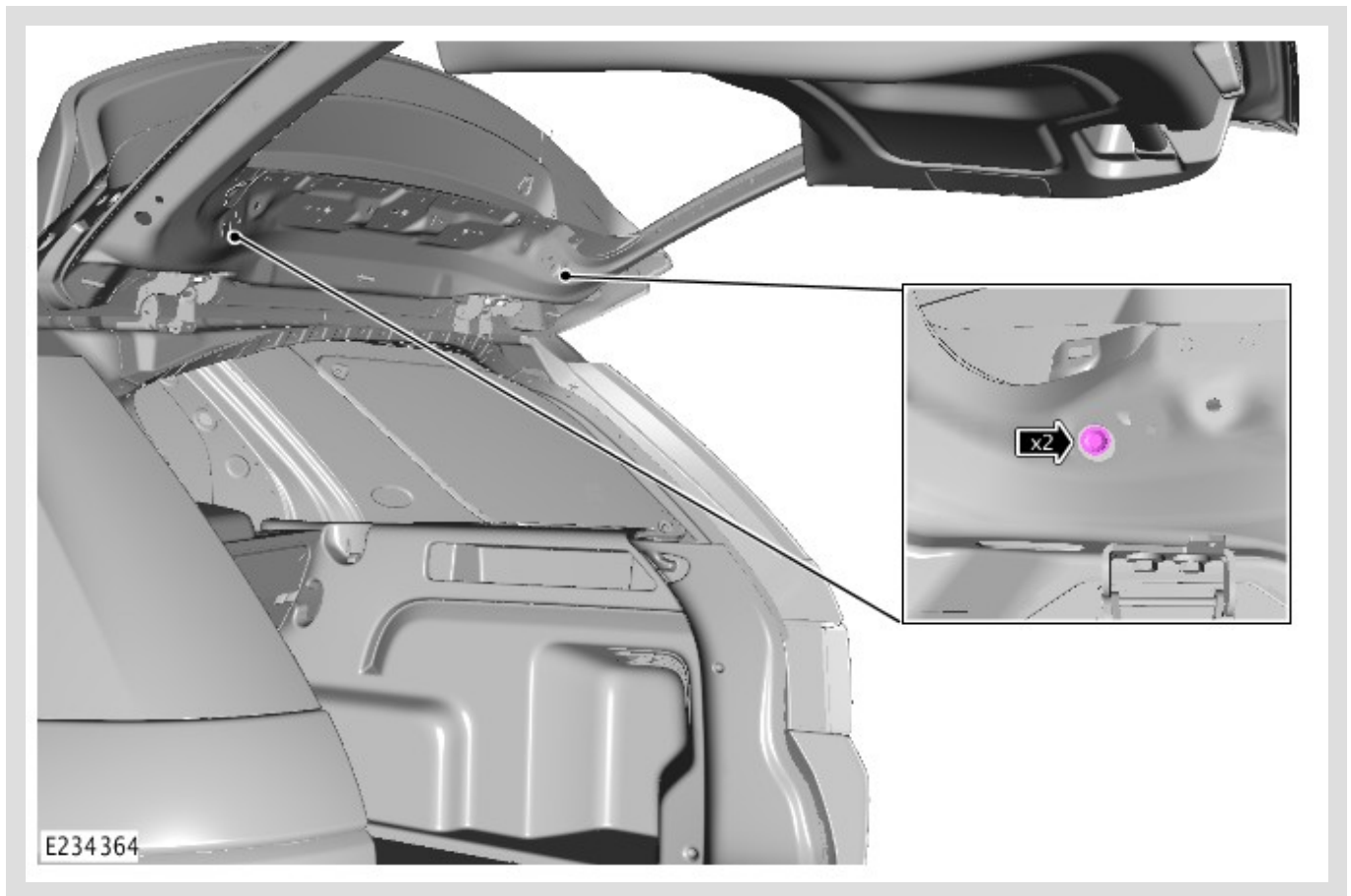

Remove rear spoiler left and right fasteners.

- 1 Retain the left fastener.
- 2 Discard the right fastener.

5 Lower the tailgate.

6 **ⓘ CAUTIONS:**

- Do not stretch or damage the wiring harness or rear washer jet hose while repositioning the rear spoiler.
- Do not to damage the vehicle body/paint while positioning the rear spoiler.

⚠ NOTE:

This step requires the assistance of another technician.

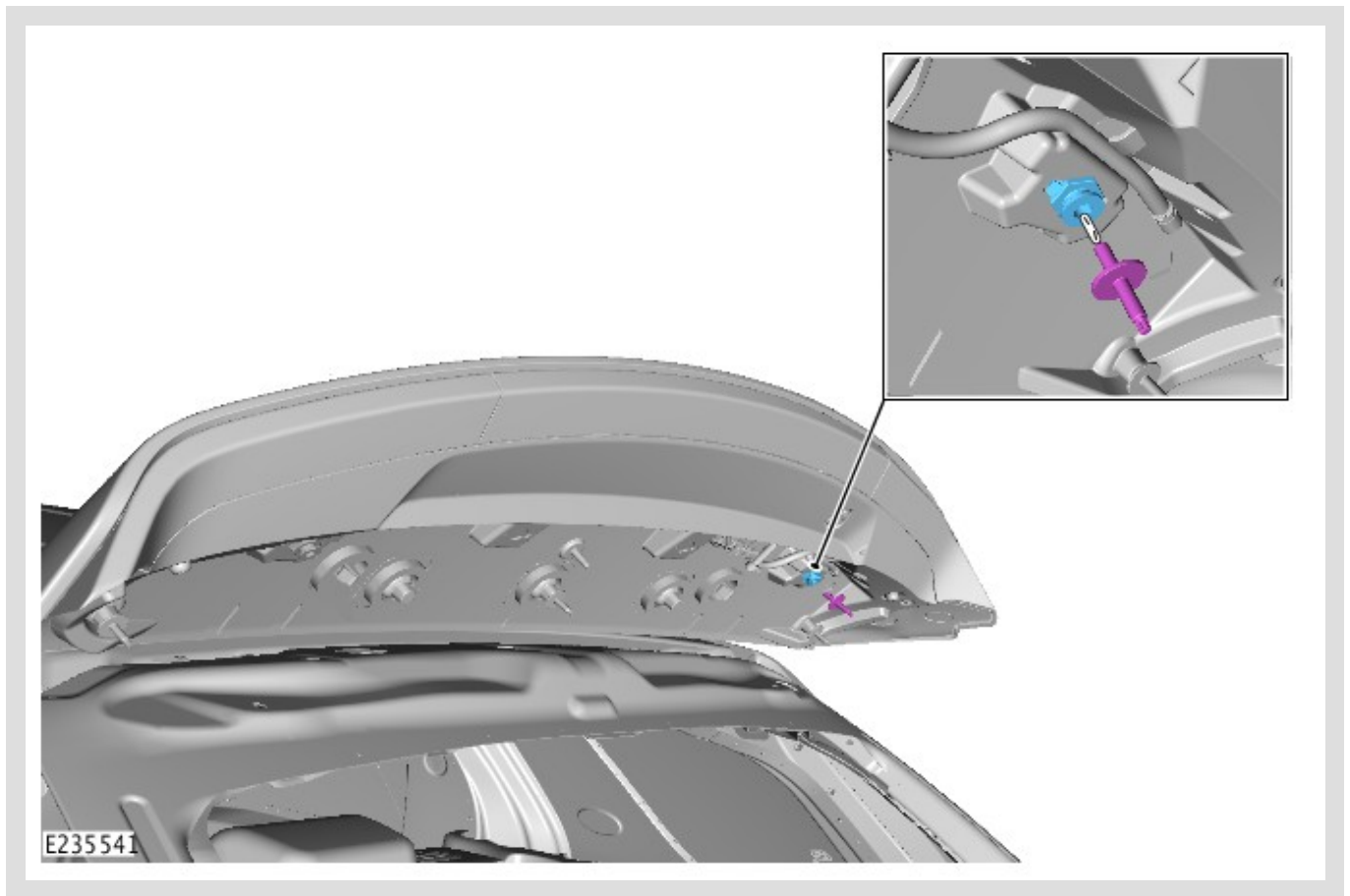

With the assistance of another technician, position the rear spoiler away from the vehicle body and install the new adjustable stud to the rear spoiler right fastener thread.

7

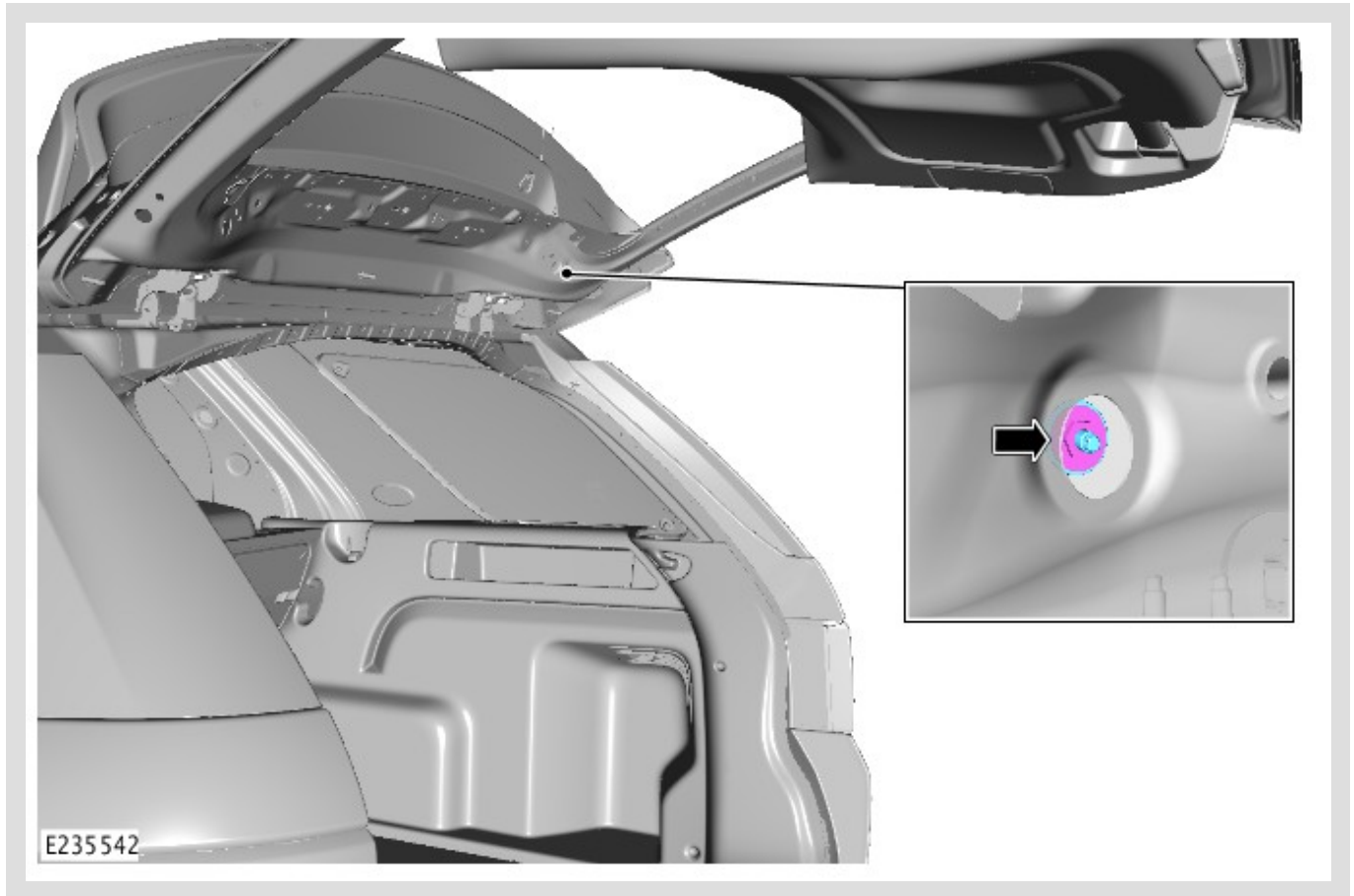

Install the rear spoiler new right washer nut(s).

- Torque: **10 Nm**

8

△ NOTE:

Use the original fastener.

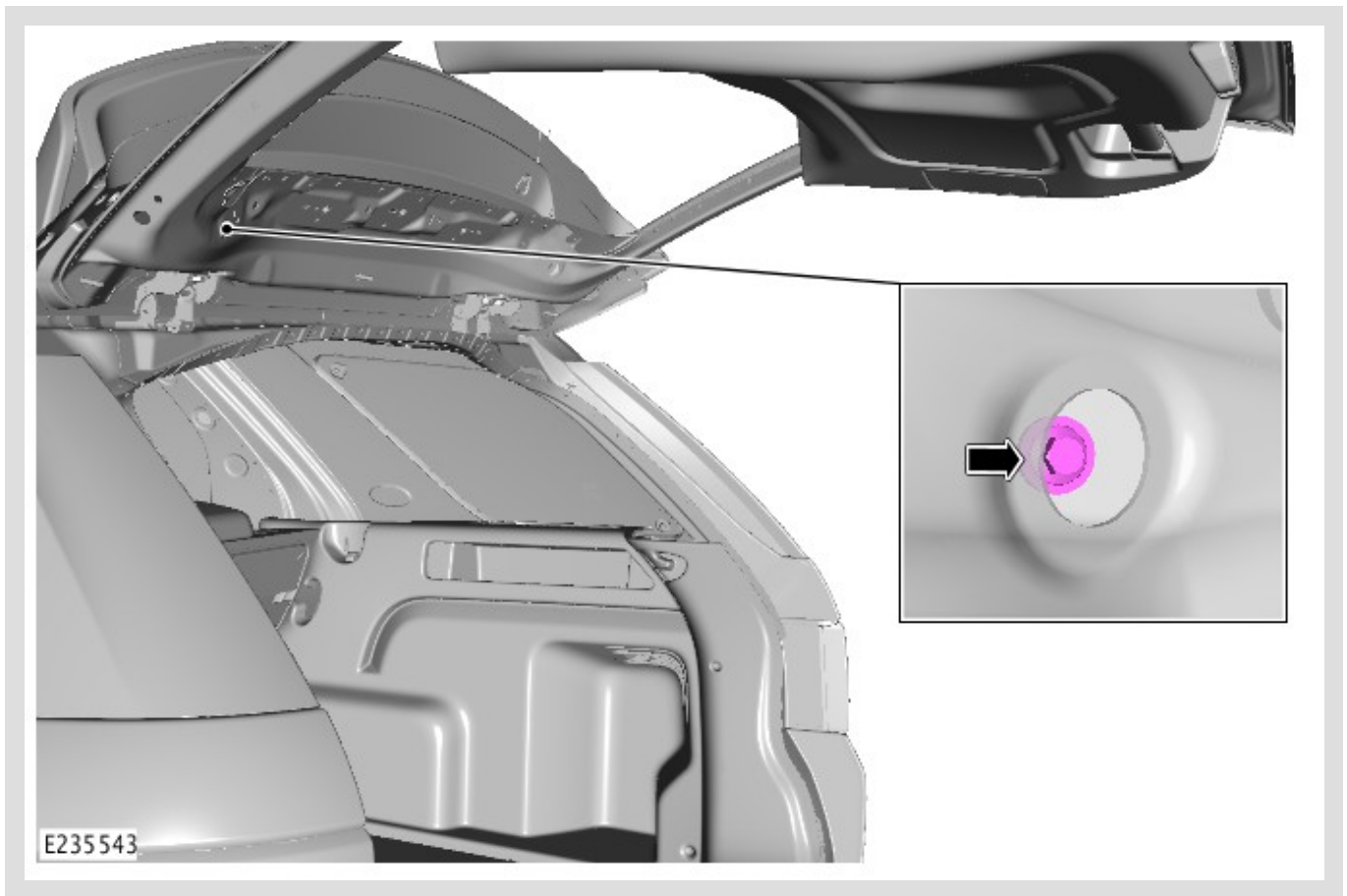

Install the rear spoiler left fastener.

- Torque: **10 Nm**

☰ Close the tailgate.

10

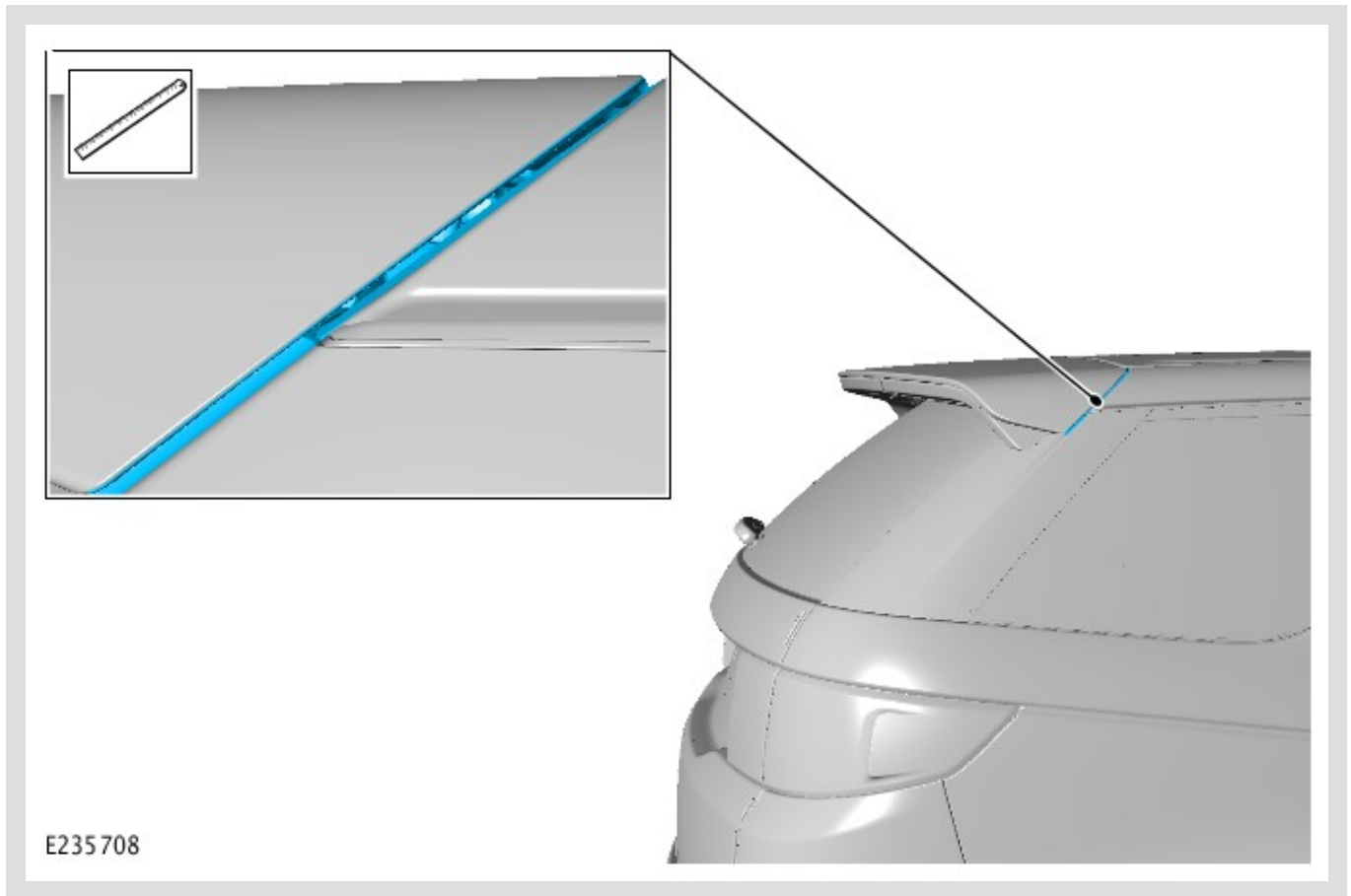

Use a suitable tool to measure and record the gap between the rear spoiler and the right outer D-pillar.

- If the gap is 2.5mm-5.5mm (in specification), inspect that the spoiler gaps are within tolerance on both sides of the vehicle.
 - Go to Step 11.
- If the gap is less than 2.5mm or greater than 5.5mm (out of specification), open the tailgate, remove the washer nut(s), and adjust the adjustable stud that was installed in Step 6.
 - Repeat Step 10 until all gaps are in specification.
 - Go to Step 11.

11 Open the tailgate.

12 Reverse steps 2-3.

13 Close the tailgate.

