

## General Information

A new design for the Saf-T-Liner C2 grille went into production on February 5, 2018. The hood design has also changed slightly to accommodate a different grille fastening strategy. The old grille and hood part numbers will no longer be produced, and will supersede to the new design with new part numbers.

## Grille Replacement

NOTE: The new grille surround design can be used with the old hoods.

To replace a grille on a hood from a vehicle built prior to February 5, 2018, the additional fasteners shown in [Table 1](#) must be used. See [Fig. 1](#) and [Fig. 2](#). Parts are available at the PDCs.

Additional Parts for Grille Replacement		
Part Number	Description	Qty.
23-10900-227	Washer, Stainless Steel	4
23-13865-006	Nut/Conical Washer Assy.	4
23-13384-020	Screw, M6	4

**Table 1, Additional Parts for Grille Replacement**

1. Park the vehicle on a level surface, shut down the engine, and set the parking brake. Chock the tires.
2. Remove the four screws that attach the grille to the hood, and discard them.
3. Remove the isolated nuts from the hood, and discard them.
4. Install the new grille, with the new washers between the grille and the hood, then attach it to the hood with the new screws and nut/conical washer assemblies. Tighten the nuts 60 to 84 lbf-in (680 to 950 N-cm).

## Hood Replacement

The old grille does not fit on the new hood design. If the old hood design is not available, a new grille is required when replacing a hood on a vehicle built prior to February 5, 2018.

## Warranty

This bulletin is informational only. Warranty does not apply.

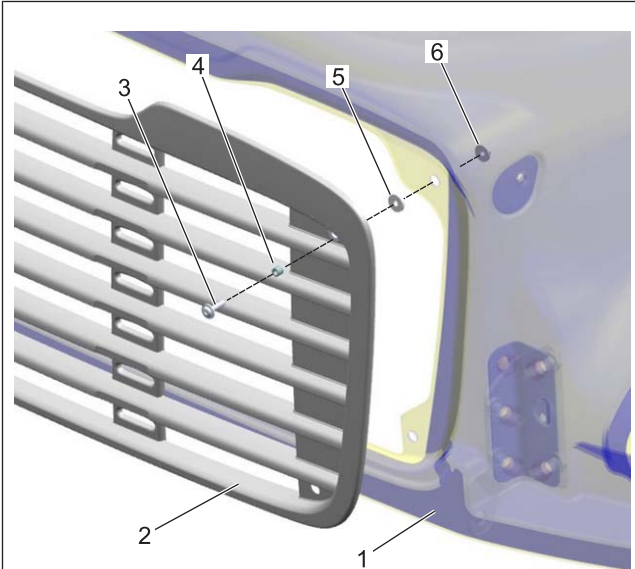

04/25/2018

f880952

1. Hood
2. Grille
3. Screw, M6 (23-13384-020)
4. Compression Limiter
5. Washer (23-10900-227)
6. Nut/Conical Washer Assy. (23-13865-006)

**Fig. 1, Grille Installation**

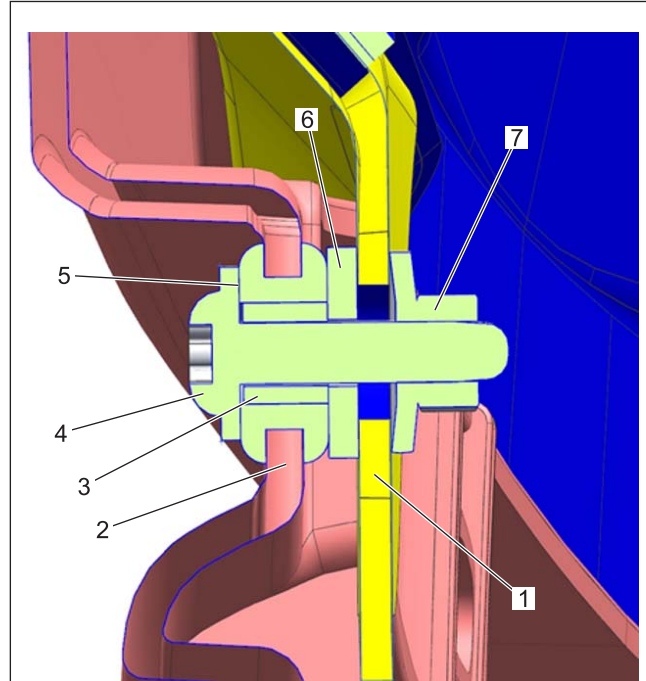

04/25/2018

f880953

1. Hood
2. Grille
3. Compression Limiter
4. Screw, M6 (23-13384-020)
5. Grommet
6. Washer (23-10900-227)
7. Nut/Conical Washer Assy. (23-13865-006)

**Fig. 2, Grille Fasteners**