



Emissions Recall

Code: 26L3

Subject	Catalytic Converter Support Bracket
Release Date	October 16, 2018
Affected Vehicles	U.S.A. & CANADA: Certain 2013-2014 MY Volkswagen Touareg with 3.6L V6 Gasoline Engine <i>Check Campaigns/Actions screen in Elsa on the day of repair to verify that a VIN qualifies for repair under this action. Elsa is the <u>only</u> valid campaign inquiry & verification source.</i> <ul style="list-style-type: none">✓ Campaign status must show “open.”✓ If Elsa shows other open action(s), inform your customer so that the work can also be completed at the same time the vehicle is in the workshop for this campaign.
Problem Description	In certain vehicles, the cylinders 4-6 catalytic converter support bracket weld may crack. If this happens, the resulting vibration increase on the exhaust system can cause the catalytic converter flange to break and illuminate the malfunction indicator light (MIL) in the instrument panel. A vehicle with a MIL on will not pass an emissions inspection.
Corrective Action	Install a support bracket onto the affected catalytic converter. Once this emissions recall repair has been completed, Volkswagen will provide a warranty extension for the catalytic converter support bracket as described in Warranty Bulletin VWP-18-10 (USA) / Warranty Service Circular CVWP-18-26 (Canada).
Parts Information	Parts will be allocated prior to owner notification. If allocated parts have been used and your dealership is at the weekly Upper Order Limit, please submit the backordered sales document number to upperorderlimits@vw.com to have additional parts released.
Code Visibility	On or about October 16, 2018, affected vehicles will be listed on the Inventory Vehicle Open Campaign Action report under My Dealership Reports (found on www.vw.com & OMD Web). A list will not be posted for dealers who do not have any affected vehicles. On or about October 16, 2018, this campaign code will show open on affected vehicles in Elsa. On or about October 16, 2018, affected vehicles will be identified with this campaign code in the VIN Lookup tool at www.vw.com .
Owner Notification	Owner notification will take place in October. Owner letter examples are included in this bulletin for your reference.
Emissions Campaigns Requirements (CALIFORNIA ONLY)	The California Air Resources Board and the Department of Motor Vehicles (DMV) require emissions-related campaigns to be completed prior to vehicle registration renewal. When campaign work is done you must provide the owner with a signed “Vehicle Emission Recall – Proof of Correction” certificate (RC EMISCAVWAU). Order certificates online via the Compliance Label Ordering portal at www.vw.com .
Additional Information	Please alert everyone in your dealership about this action, including Sales, Service, Parts and Accounting personnel. Contact Warranty if you have any questions. Dealers must ensure that every affected inventory vehicle has this campaign completed <u>before delivery to consumers</u> . Fill out and affix Campaign Completion Label (CAMP 010 000) after work is complete. Labels can be ordered at no cost via the Compliance Label Ordering portal at www.vw.com .

Claim Entry Instructions

After campaign has been completed, enter claim as soon as possible to help prevent work from being duplicated elsewhere. Attach the Elsa screen print showing action open on the day of repair to the repair order.

If customer refused campaign work:

- ✓ U.S. dealers: Submit request via WISE under the *Campaigns/Update/Recall Closure* option.
- ✓ Canada dealers: Upload the repair order [signed by customer] to Volkswagen WIN/Operations/Campaign Closure.

Service Number	26L3									
Damage Code	0099									
Parts Vendor Code	WWO									
Claim Type	Sold vehicle: 7 10 Unsold vehicle: 7 90									
Causal Indicator	Mark Catalyst Bracket as causal part									
Vehicle Wash/Loaner	Do not claim wash/loaner under this action									
Criteria I.D.	01									
	Install Catalyst Bracket Labor operation: 2674 23 99 90 T.U. <table border="1"><thead><tr><th>Quantity</th><th>Part Number</th><th>Description</th></tr></thead><tbody><tr><td>1.00</td><td>7P0253309A</td><td>Catalyst bracket and clamp</td></tr><tr><td>1.00</td><td>N 10653102</td><td>Bolt</td></tr></tbody></table>	Quantity	Part Number	Description	1.00	7P0253309A	Catalyst bracket and clamp	1.00	N 10653102	Bolt
Quantity	Part Number	Description								
1.00	7P0253309A	Catalyst bracket and clamp								
1.00	N 10653102	Bolt								

Customer Letter Example (United States)

Subject: Emissions Recall 26L3 - Catalytic Converter Support Bracket & Warranty Extension Certain 2013-2014 Model Year Volkswagen Touareg 3.6L V6 Gasoline Engine Vehicles

Dear Volkswagen Owner,

In cooperation with the United States Environmental Protection Agency and the California Air Resources Board, we are informing you of our decision to conduct an emissions recall and provide an extended warranty on certain 2013-2014 model year Volkswagen Touareg 3.6L V6 gasoline engine vehicles. Our records show that you are the owner of a vehicle affected by these actions.

Emissions Recall 26L3

What is the issue?	In certain vehicles, the cylinders 4-6 catalytic converter support bracket weld may crack. If this happens, the resulting vibration increase on the exhaust system can cause the catalytic converter flange to break and illuminate the malfunction indicator light (MIL) in the instrument panel. A vehicle with a MIL on will not pass an emissions inspection.
What will we do?	Your authorized Volkswagen dealer will install a support bracket onto the affected catalytic converter. This work may take up to a day to complete and will be performed for you free of charge. Please keep in mind that your dealer may need additional time for the preparation of the repair, as well as to accommodate their daily workshop schedule.
What should you do?	Please contact your authorized Volkswagen dealer as soon as possible to schedule this service. To set up an appointment online, please visit www.vw.com/find-a-dealer .
Important information for California Vehicle Owners – California Regulations	California regulations require that this campaign be completed prior to the time you renew your vehicle registration. Therefore, please make sure that this campaign is completed prior to the renewal of your vehicle registration , and that you furnish proof of completion to the Department of Motor Vehicles (DMV) in the form of a copy of the dealer's repair order, including a signed "Proof of Correction" certificate. You obtain this from your dealer after the campaign has been completed. Please retain the signed "Proof of Correction Certificate" with your vehicle records. DO NOT MAIL THIS FORM to the DMV, unless requested.

Warranty Extension Coverage for Catalytic Converter Support Bracket Weld (Post- 26L3 Repair)

After Emissions Recall 26L3 has been completed on your vehicle, Volkswagen will extend warranty coverage for the catalytic converter support bracket weld in your vehicle (under specific conditions) to 10 years or 120,000 miles, whichever occurs first, from the vehicle's original in-service date.

Warranty Extension Coverage/Limitations	<p>If the MIL in your vehicle comes on and stays on while your vehicle is within the time and mileage limits of this warranty extension, at no cost to you, an authorized Volkswagen dealer will perform a diagnosis to determine if the light is on due to a faulty catalytic converter support bracket weld.</p> <ul style="list-style-type: none">• If diagnosis confirms that your vehicle has the issue, the repair will be performed at no cost to you.• If diagnosis reveals that your vehicle has an <u>unrelated issue(s)</u>, any necessary repairs will not be covered under this warranty extension. Your dealer will advise you what the associated repair cost(s) will be.
What you should do	<ul style="list-style-type: none">• Ensure all vehicle drivers have read the vehicle owner's manual so they are familiar with how the emissions system and associated warning lights (including the MIL) work. In some locales, an illuminated Malfunction Indicator Lamp could cause your vehicle to fail an emissions inspection, and your vehicle registration application could be denied.• Please be aware that other conditions (unrelated to the issue described in this letter) may cause the MIL in your vehicle to illuminate. Customers should be prepared to cover diagnosis and repair costs associated with these other, unrelated conditions.• Please keep this letter with your Warranty booklet for future reference, and deliver it to any new owner, along with the owner's manual. Should you ever sell the vehicle, this warranty extension is fully transferable to subsequent owners.
Additional information regarding this warranty extension	<ul style="list-style-type: none">• A vehicle is not eligible for the extended warranty coverage described in this letter if it has a branded title (including, but not limited to: "Totaled," "Assembled," "Dismantled," "Flood," "Junk," "Rebuilt," "Reconstructed," "Lemon Law Buyback," "Fleet," "Mileage Unknown," "Stolen," or "Salvaged," or if it was acquired by any person or entity from a junkyard, salvage facility, or body shop).• The warranty and maintenance information that came with your vehicle contains information on the limited warranties applicable to your vehicle. Please read these limited warranties carefully to determine your warranty rights and obligations, as this information also applies to the coverage provided to you in this warranty extension.• Damage or malfunctions caused by outside influence, such as damage due to an accident, or vehicle misuse or neglect, and repairs that are necessary for proper diagnosis of these conditions or required to bring the vehicle up to factory specifications are not covered by this warranty extension.
Lease vehicles and address changes	If you are the lessor and registered owner of the vehicle identified in this action, please forward this letter immediately via first-class mail to the lessee within ten (10) days of receipt. If you have changed your address or sold the vehicle, please fill out the enclosed prepaid Owner Reply card and mail it to us so we can update our records.

The repair information in this document is intended for use only by skilled technicians who have the proper tools, equipment and training to correctly and safely maintain your vehicle. These procedures are not intended to be attempted by "do-it-yourselfers," and you should not assume this document applies to your vehicle, or that your vehicle has the condition described. To determine whether this information applies, contact an authorized Volkswagen dealer. ©2018 Volkswagen Group of America, Inc. and Volkswagen Canada. All Rights Reserved.

Reimbursement of Expenses

If you have previously paid for repairs relating to the condition described in this letter, please refer to the enclosed form that explains how to request reimbursement.

Can we assist you further?

If your authorized Volkswagen dealer fails or is unable to complete this work free of charge within a reasonable time, or if you should have any questions about this communication, please reach out to us using your preferred method of communication at www.vw.com/contact or by calling us at 800-893-5298.

Checking your vehicle for open Recalls and Service Campaigns

To check your vehicle's eligibility for repair under this or any other recall/service campaign, please visit www.vw.com/owners/recalls and enter your Vehicle Identification Number (VIN) into the Recall/Service Campaign Lookup tool.

We apologize for any inconvenience this matter may cause; however we are taking this action to help ensure your vehicle continues to meet and exceed your expectations.

Sincerely,

Volkswagen Customer Protection

Customer Letter Example (CANADA)

Subject: Emissions Recall 26L3 - Catalytic Converter Support Bracket & Warranty Extension Certain 2013-2014 Model Year Volkswagen Touareg 3.6L V6 Gasoline Engine Vehicles

Dear Volkswagen Owner,

This notice is sent to you in accordance with the requirements of the *Canadian Environmental Protection Act, 1999*. Volkswagen has determined that a defect, which relates to a prescribed emission standard, exists in certain 2013-2014 model year Volkswagen Touareg 3.6L V6 gasoline engine vehicles. Our records show that you are the owner of a vehicle affected by this action.

Volkswagen is providing you with an emissions recall repair and extended warranty coverage for the catalytic converter support bracket weld as described in this letter.

Emissions Recall 26L3

- What is the issue?** In certain vehicles, the cylinders 4-6 catalytic converter support bracket weld may crack. If this happens, the resulting vibration increase on the exhaust system can cause the catalytic converter flange to break and illuminate the malfunction indicator light (MIL) in the instrument panel. A vehicle with a MIL on will not pass an emissions inspection.
- This defect, if present, has an impact on tailpipe emissions.
- What will we do?** Your authorized Volkswagen dealer will install a support bracket onto the affected catalytic converter. This work may take up to a day to complete and will be performed for you free of charge. Please keep in mind that your dealer may need additional time for the preparation of the repair, as well as to accommodate their daily workshop schedule.
- What should you do?** In order to limit any possible inconvenience, please contact your authorized Volkswagen dealer as soon as possible to schedule this service. On or about October XX, 2018 the necessary repair instructions and parts will be available to your authorized Volkswagen dealer.

Warranty Extension Coverage for Catalytic Converter Support Bracket Weld (Post- 26L3 Repair)

After Emissions Recall 26L3 has been completed on your vehicle, Volkswagen will extend warranty coverage for the catalytic converter support bracket weld in your vehicle (under specific conditions) to 10 years or 193,000 kilometers, whichever occurs first, from the vehicle's original in-service date.

Warranty Extension Coverage/Limitations If the MIL in your vehicle comes on and stays on while your vehicle is within the time and mileage limits of this warranty extension, at no cost to you, an authorized Volkswagen dealer will perform a diagnosis to determine if the light is on due to a faulty catalytic converter support bracket weld.

- If diagnosis confirms that your vehicle has the issue, the repair will be performed at no cost to you.
- If diagnosis reveals that your vehicle has an unrelated issue(s), any necessary repairs will not be covered under this warranty extension. Your dealer will advise you what the associated repair cost(s) will be.

What you should do

- Ensure all vehicle drivers have read the vehicle owner's manual so they are familiar with how the emissions system and associated warning lights (including the MIL) work. In some locales, an illuminated Malfunction Indicator Lamp could cause your vehicle to fail an emissions inspection, and your vehicle registration application could be denied.
- Please be aware that other conditions (unrelated to the issue described in this letter) may cause the MIL in your vehicle to illuminate. Customers should be prepared to cover diagnosis and repair costs associated with these other, unrelated conditions.
- Please keep this letter with your Warranty booklet for future reference, and deliver it to any new owner, along with the owner's manual. Should you ever sell the vehicle, this warranty extension is fully transferable to subsequent owners.

Additional information regarding this warranty extension

- A vehicle is not eligible for the extended warranty coverage described in this letter if it has a branded title (including, but not limited to: "Totaled," "Assembled," "Dismantled," "Flood," "Junk," "Rebuilt," "Reconstructed," "Lemon Law Buyback," "Fleet," "Mileage Unknown," "Stolen," or "Salvaged," or if it was acquired by any person or entity from a junkyard, salvage facility, or body shop).

- The warranty and maintenance information that came with your vehicle contains information on the limited warranties applicable to your vehicle. Please read these limited warranties carefully to determine your warranty rights and obligations, as this information also applies to the coverage provided to you in this warranty extension.
- Damage or malfunctions caused by outside influence, such as damage due to an accident, or vehicle misuse or neglect, and repairs that are necessary for proper diagnosis of these conditions or required to bring the vehicle up to factory specifications are not covered by this warranty extension.

Lease vehicles and address changes If you are the lessor and registered owner of the vehicle identified in this action, please forward this letter immediately via first-class mail to the lessee within ten (10) days of receipt. If you have changed your address or sold the vehicle, please fill out the enclosed prepaid Owner Reply card and mail it to us so we can update our records.

Reimbursement of Expenses

If you have previously paid for repairs relating to the condition described in this letter, please refer to the enclosed form that explains how to request reimbursement.

Can we assist you further?

If your authorized Volkswagen dealer fails or is unable to complete this work free of charge within a reasonable time, please contact Customer Relations, Monday through Friday from 8AM to 8PM EST by phone at 1-800-822-8987 or via our "Contact Us" page at www.vw.ca.

We apologize for any inconvenience this matter may cause; however we are taking this action to help ensure your vehicle continues to meet and exceed your expectations.

Sincerely,

Volkswagen Customer Protection

NOTE

- Damages resulting from improper repair or failure to follow these work instructions are the dealer's responsibility and are not eligible for reimbursement under this action.
- This procedure must be read in its entirety prior to performing the repair.
- Due to variations in vehicle equipment and options, the steps/illustrations in this work procedure may not identically match all affected vehicles.
- Diagnosis and repair of pre-existing conditions in the vehicle are not covered under this action.
- When working during extreme temperatures, it is recommended that the vehicle be allowed to acclimate inside the shop to avoid temperature-related component damage/breakage.

Repair Overview

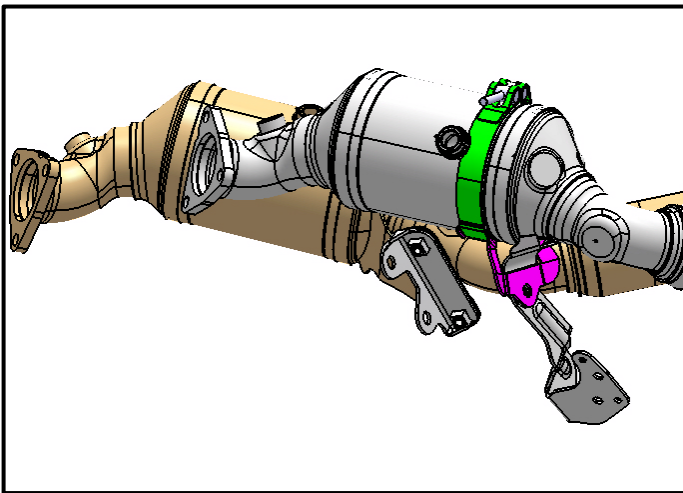

- Install a bracket and clamp to the catalyst for cylinders 4, 5 and 6.

Required Parts

<u>Criteria</u>	<u>Quantity</u>	<u>Part Number</u>	<u>Part Description</u>
01	1	7P0.253.309.A	Catalyst bracket and clamp
	1	N 106.531.02	Bolt

Required Tools

	<p>Torque Wrench 5-50 Nm -VAG1331- (or equivalent)</p>
--	--



The repair information in this document is intended for use only by skilled technicians who have the proper tools, equipment and training to correctly and safely maintain your vehicle. These procedures are not intended to be attempted by "do-it-yourselfers," and you should not assume this document applies to your vehicle, or that your vehicle has the condition described. To determine whether this information applies, contact an authorized Volkswagen dealer. ©2018 Volkswagen Group of America, Inc. and Volkswagen Canada. All Rights Reserved.

Repair Instruction

Section A - Check for Previous Repair

TIP

If Campaign Completion label is present, no further work is required.

Applicable criteria ID(s)	Campaign/Action Status
01 	Open 

EXAMPLE

- Enter the VIN in Elsa and proceed to the “Campaign/Action” screen.

TIP

On the date of repair, print this screen and keep a copy with the repair order.

- Confirm the Campaign/Action is open <arrow 1>. If the status is closed, no further work is required.
- Note the Applicable Criteria ID <arrow 2> for use in determining the correct work to be done and corresponding parts associated.

Proceed to Section B

Section B – Repair Procedure

WARNING

Exhaust components can be extremely hot. Use heat resistant safety gloves and sleeves or allow the exhaust system to cool before working on it to avoid burn injuries.

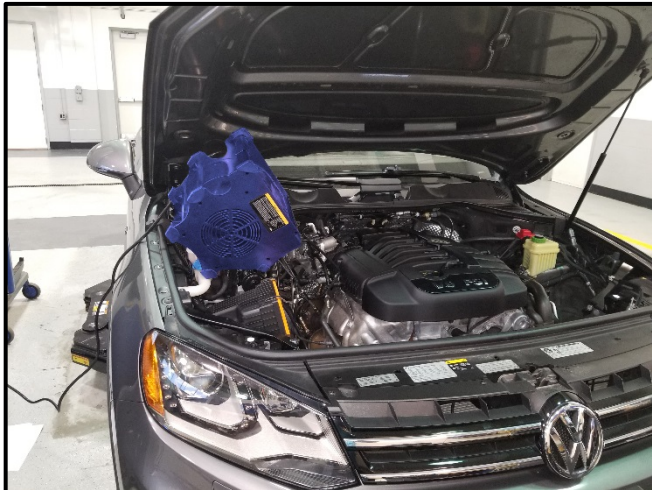

- Using a portable fan will aid in cooling the exhaust.

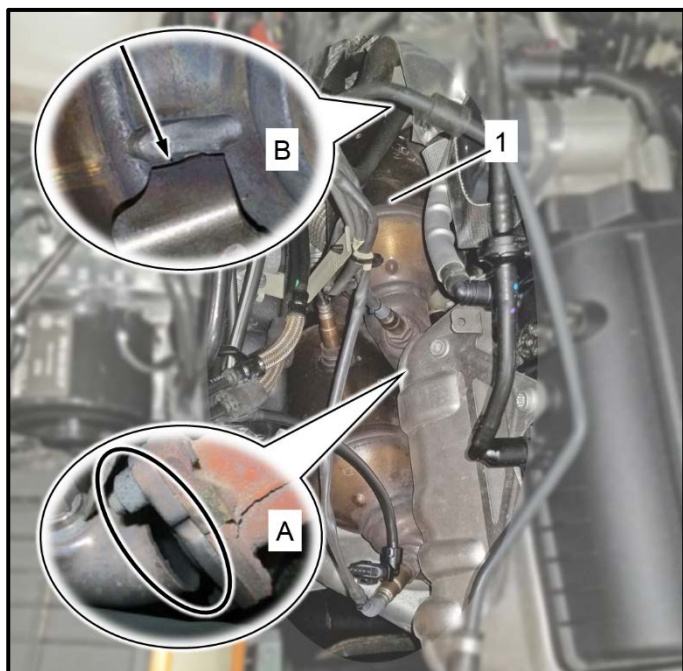

NOTE

- If the vehicle arrives with an active exhaust leak from a broken flange <A> on the cylinder 4, 5 and 6 catalyst <1>, the catalyst must be replaced.
- A broken flange would be a result of a broken weld on the existing catalyst bracket.
- The likelihood of this occurring is extremely rare.
- At the time of this repair, if a cracked flange is found:
 - U.S. dealers: Provide photos of the cracked flange, the broken weld on the catalyst, and the repair order and submit a campaign authorization request for consequential damage.
 - Canadian dealers: Create a VTA WEB ticket and attach photos of the cracked flange, the broken weld on the catalyst and the repair order.

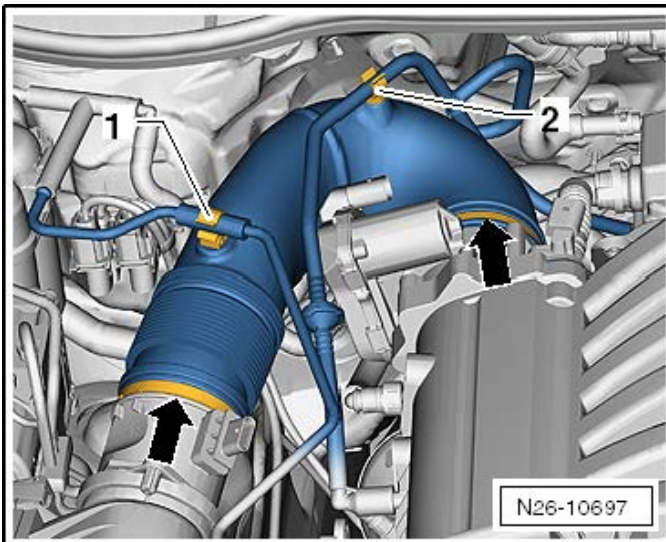

- Unclip hoses <1 and 2> from connecting hose.
- Release clamps <arrows> and remove connecting hose.
- Remove upper section of air filter housing.

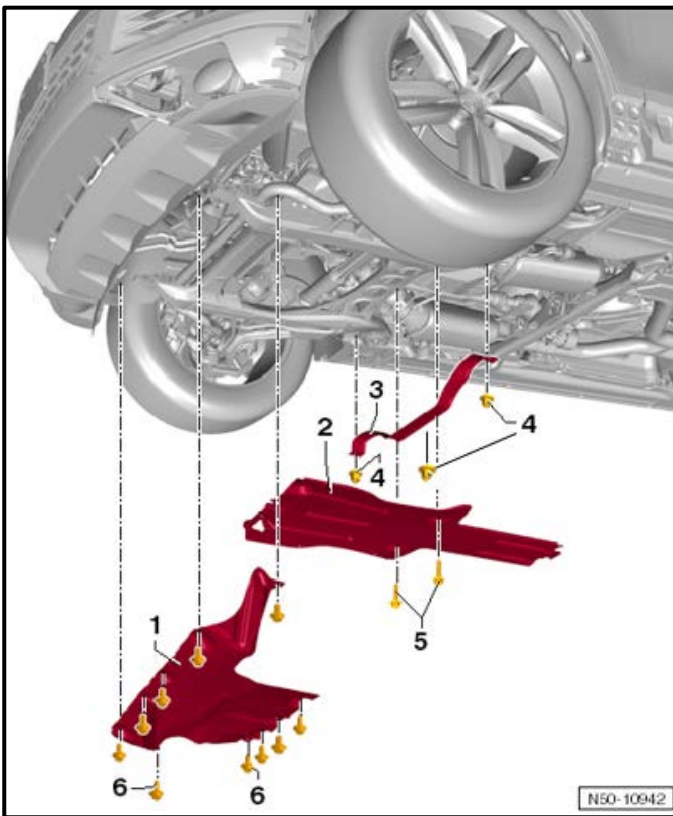

- Raise vehicle.
- Remove bolts <6> and remove front noise insulation <1>.
- Remove bolts <5> and remove rear noise insulation <2>.
- Remove fasteners <4> and bracket <3>.

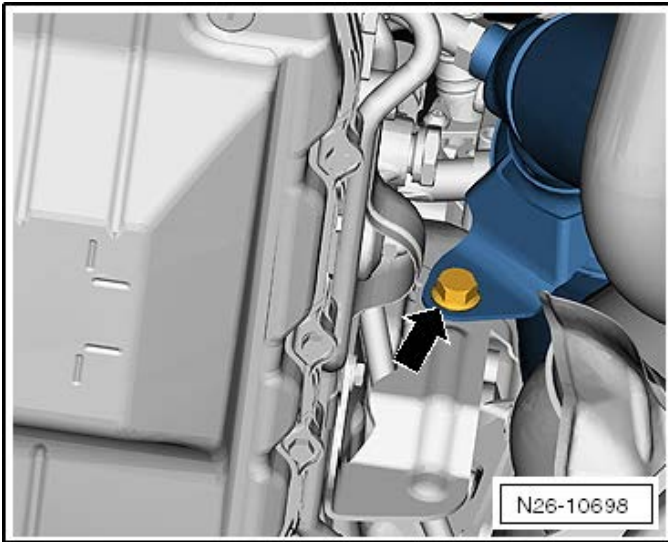

- Remove bolt <arrow>.

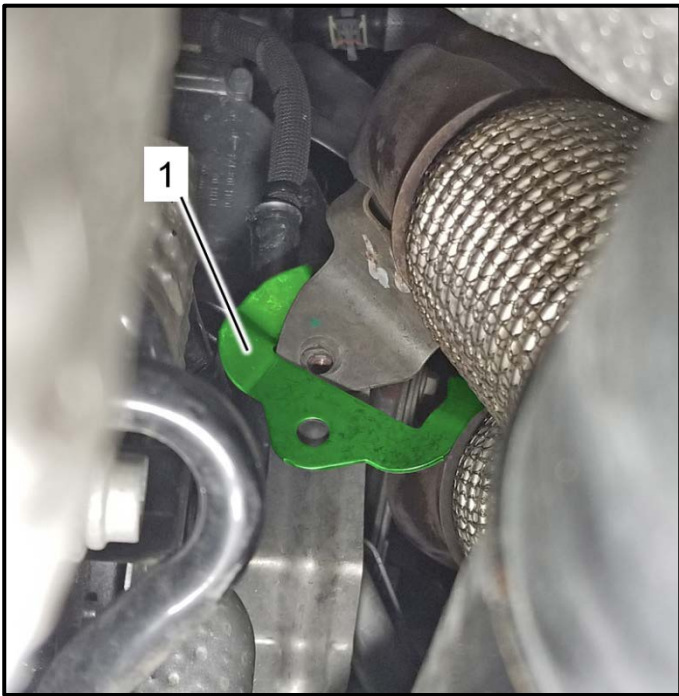

- Position bracket <1>.
- Make sure “fingers” are pointing toward the front of the vehicle.

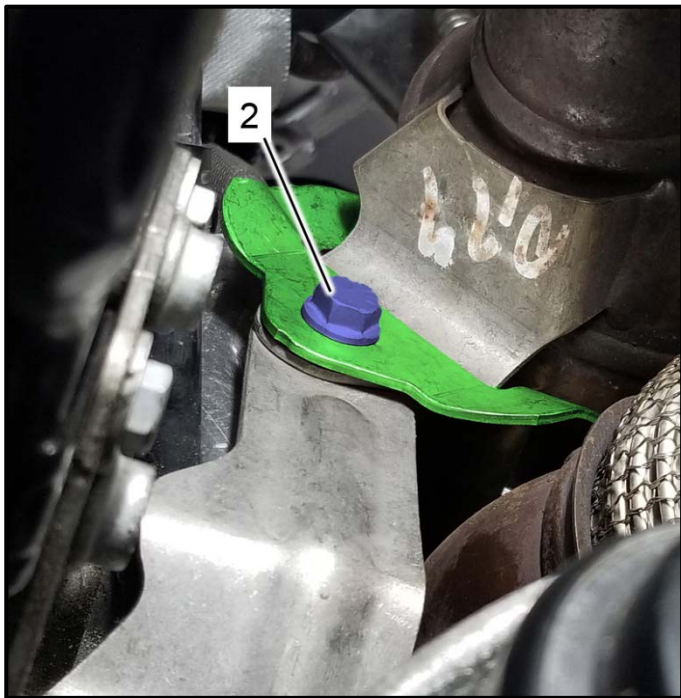

- Install new bolt <2> and torque to 23 Nm.

Part Number	Part Description
N 106.531.02	Bolt

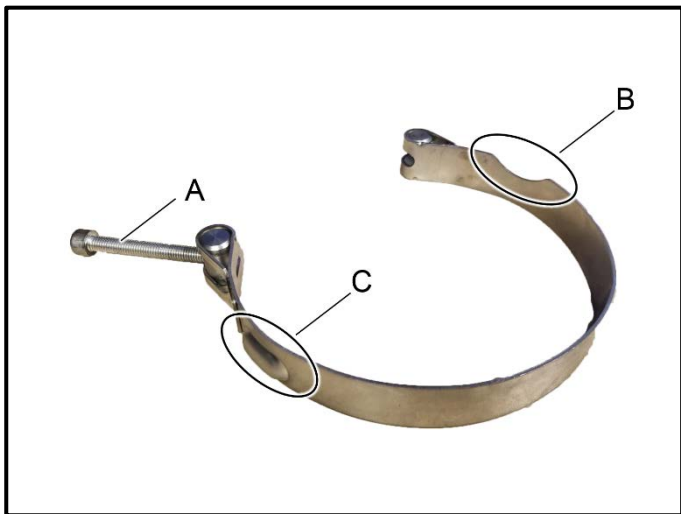

- Open clamp so it will fit over the catalyst.
- Unscrew bolt <A> nearly all the way.
- Clamp will be positioned so that recess will be around the rear of the rear oxygen sensor.
- The recess faces the front of the vehicle.
- The bulge <C> faces the passenger side of the vehicle.

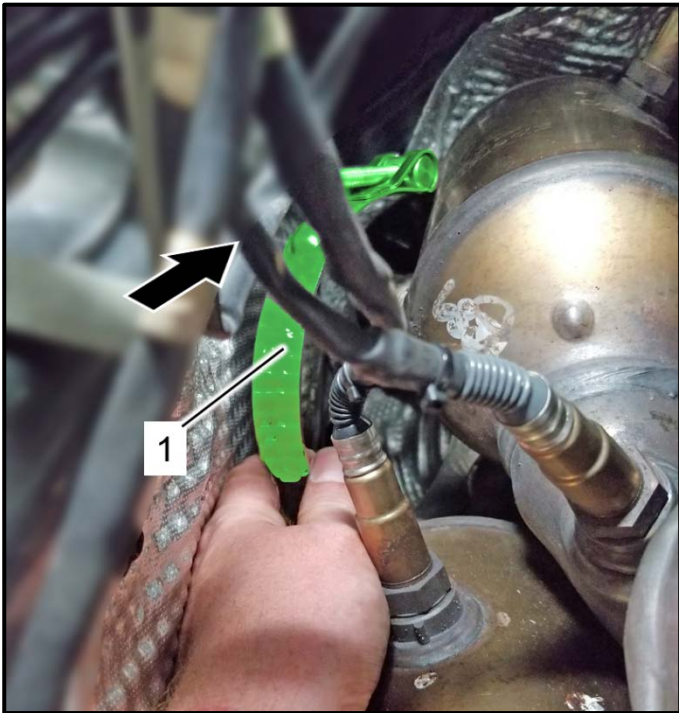

- Lower vehicle.
- Insert clamp <1> towards the rear of the vehicle <arrow>.
- Install clamp around catalyst.

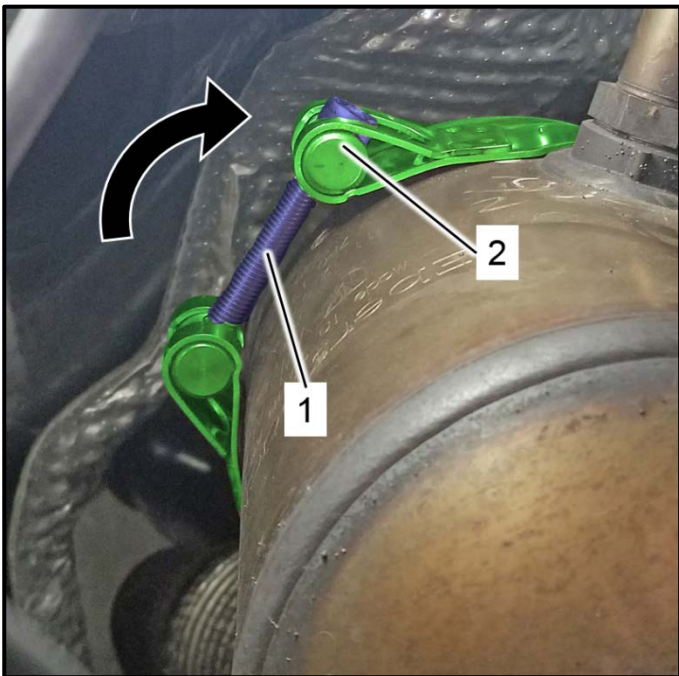

- Rotate bolt <1> down and install into clamp <2>.
- Pretension clamp to a point that will still allow some movement for correct positioning.

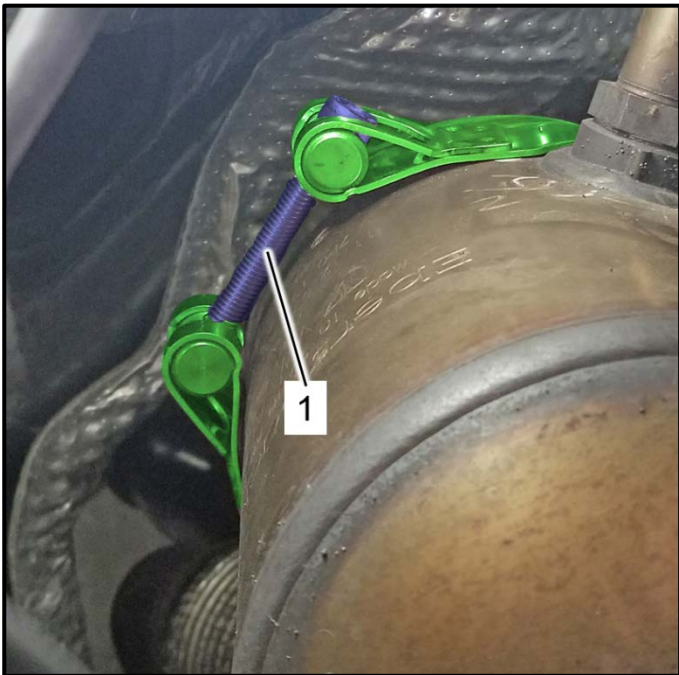
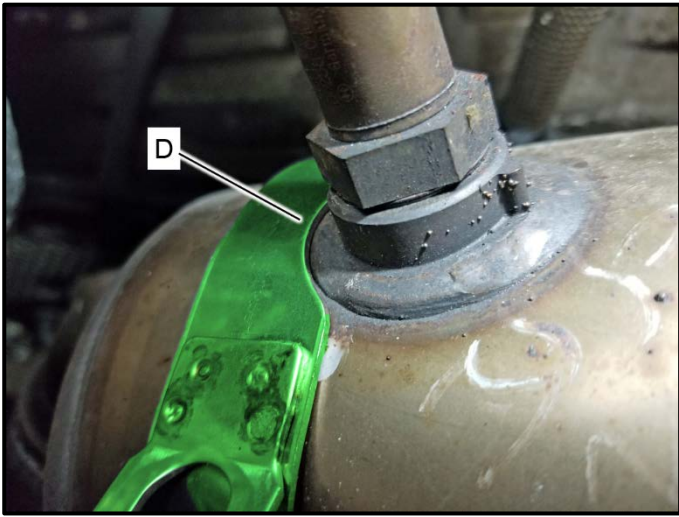
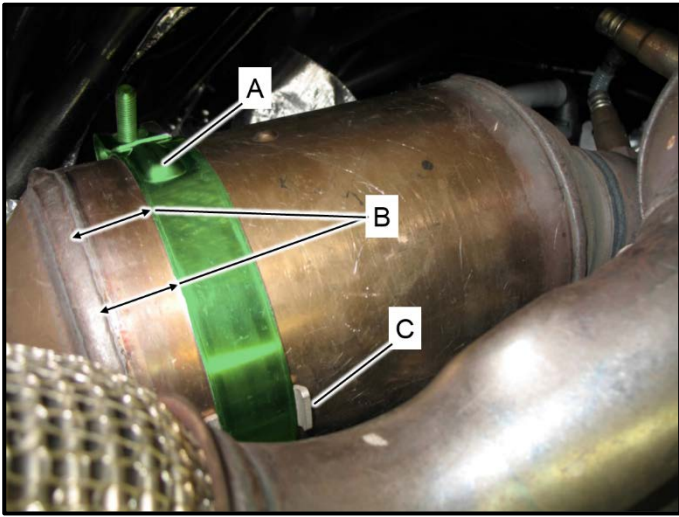

- Verify positioning of clamp:
 - A. The bulge on the clamp must cover the embossing on the catalyst.
 - B. The clamp must be parallel to the weld.
 - C. The clamp must be over the bracket.
 - D. The cutout must fit around the rear of the rear oxygen sensor.

- Torque bolt <1> to 10 Nm and re-verify positioning of clamp. Adjust clamp as needed.

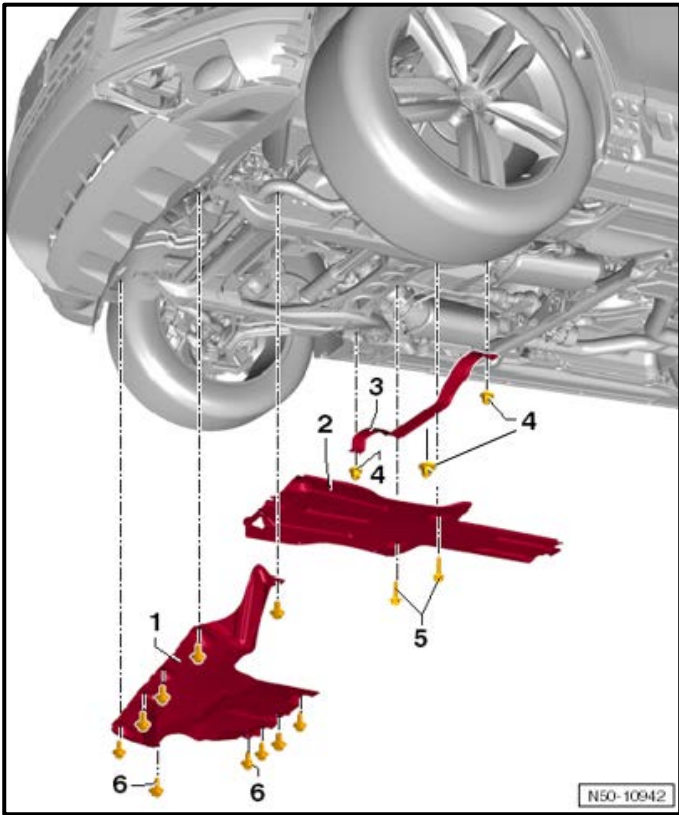

- Install bracket <3> and torque fasteners <4> to 6 Nm.
- Install front and rear noise insulation <1 and 2> and torque bolts to 6 Nm.

Proceed to Section C.

Section C – Campaign Completion Label

Install Campaign Completion Label

- Fill out and affix Campaign Completion Label, part number CAMP 010 000, next to the vehicle emission control information label.

TIP

Ensure Campaign Completion Label does not cover any existing label(s).

Proceed to Section D.

Section D - Parts Return/Disposal

Properly store (retain), destroy or dispose of removed parts in accordance with all state/province and local requirements, unless otherwise indicated and/or requested through the Warranty Parts Portal (WPP) for U.S. and the Part Destruction and Core Disposition Report for Canada.

Proceed to Section E (California only).

Section E – California Only Requirements

CALIFORNIA ONLY Requirements for Emissions Campaigns Having Customer Notification

The California Air Resources Board and the Department of Motor Vehicles (DMV) require emissions-related campaigns to be completed prior to vehicle registration renewal. **When campaign work is done you must provide the owner with a signed “Vehicle Emission Recall – Proof of Correction” certificate (RC EMIS_CAL VW).** Certificates can be ordered at no cost online via the Compliance Label Ordering portal at www.vwhub.com.

TIP

Ensure owners are aware of the importance of retaining the completed certificate for their records. It should be mailed to the California DMV only upon request.