



JTB00609NAS3

# TECHNICAL BULLETIN

17 SEP 2018

© Jaguar Land Rover North America, LLC

NOTE: The information in Technical Bulletins is intended for use by trained, professional Technicians with the knowledge, tools, and equipment required to do the job properly and safely. It informs these Technicians of conditions that may occur on some vehicles, or provides information that could assist in proper vehicle service. The procedures should not be performed by 'do-it-yourselfers'. If you are not a Retailer, do not assume that a condition described affects your vehicle. Contact an authorized Jaguar service facility to determine whether this bulletin applies to a specific vehicle.

## INFORMATION

This reissue replaces all previous versions. Please destroy all previous versions.

Changes are highlighted in blue

### SECTION:

204-00

### SUBJECT/CONCERN:

Boom Noise Heard In The Passenger Compartment

### AFFECTED VEHICLE RANGE:

| MODEL:        | MODEL YEAR:  | VIN:           |
|---------------|--------------|----------------|
| F-PACE (X761) | 2017 Onwards | 045068 Onwards |

### MARKETS:

NORTH AMERICA

### CONDITION SUMMARY:

#### SITUATION:

A boom noise may be heard in the passenger compartment when the vehicle is in motion.

#### CAUSE:

This may be caused by one or more of the following:

- Incorrect rear subframe alignment;
- Incorrect alignment of the tailgate; and/or
- Incorrect alignment of the exhaust system.

**ACTION:**

Should a customer express this concern, follow the Workshop Procedures below.

**PARTS:**

| PART NUMBER | DESCRIPTION    | QUANTITY |
|-------------|----------------|----------|
| T2H3200     | Subframe bolts | 4        |

**TOOLS:**

Refer to Workshop Manual for any required special tools.

**WARRANTY:****NOTES:**

- Repair procedures are under constant review, and therefore times are subject to change; those quoted here must be taken as guidance only. Always refer to JLR claims submission system to obtain the latest repair time.
- The JLR Claims Submission System requires the use of causal part numbers. Labor only claims must show the causal part number with a quantity of zero.

| DESCRIPTION  | SRO         | TIME (HOURS) | CONDITION CODE | CAUSAL PART |
|--|-------------|--------------|----------------|-------------|
| Rear subframe - Noise, Vibration and Harshness (NVH) rectification   | 64.91.24    | 2.0          | 12             | T4N9660     |
| Tailgate - Adjust  | 76.19.55    | 0.1          | 12             | T4N9660     |
| Exhaust alignment - Ingenium I4 2.0L Diesel; Ingenium I4 2.0L Petrol | 30.10.89.03 | 0.4          | 12             | T4N9660     |
| Exhaust alignment - V6 3.0L S/C Petrol                               | 30.10.89.03 | 1.1          | 12             | T4N9660     |
| Road test  | 10.10.13    | 0.2          | 12             | T4N9660     |

**NOTE:**

Normal Warranty procedures apply.

**WORKSHOP PROCEDURE 'A':****NOTES:**

- Removal steps in this procedure may contain installation details.
- Some variation in the illustrations may occur but the essential information is always correct.
- Rear wheel and tire assemblies shown removed for clarity.

**1** Raise and support the vehicle (see TOPIx Workshop Manual section 100-02: Jacking and lifting - Description and operation - Lifting).

2

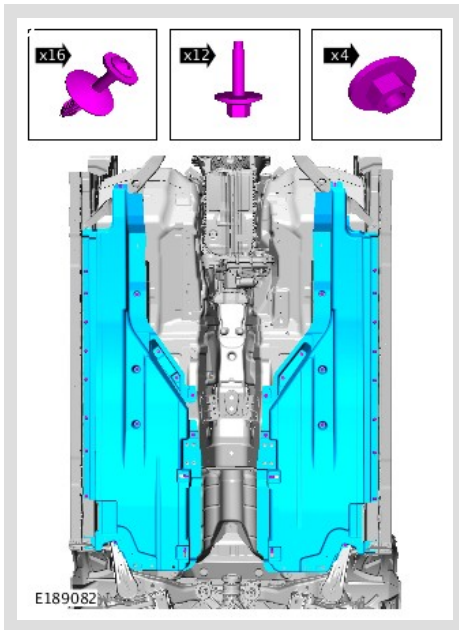

Remove the left and right undershields.

3

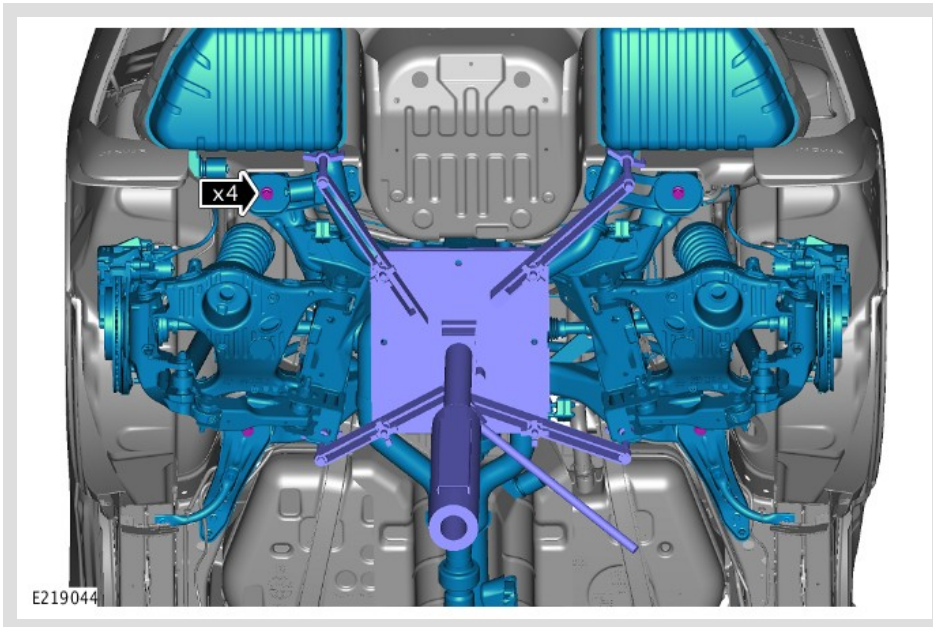

Support the rear subframe assembly with a suitable transmission jack.

- 1 Remove and discard the 4 subframe retaining bolts.

4

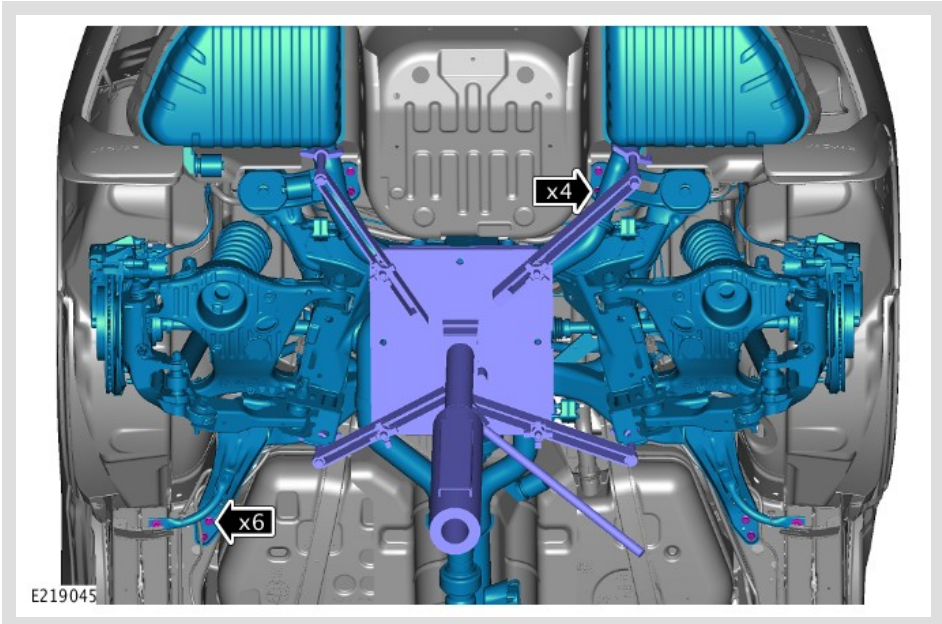

Loosen (only) the subframe support plate retaining bolts (6) and nuts (4).

5

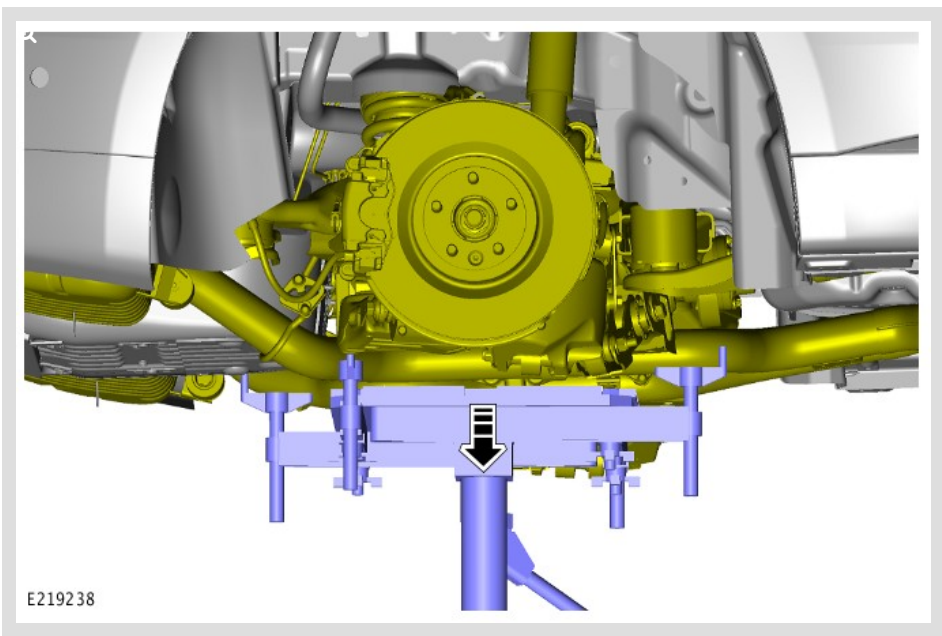

Release the transmission jack and allow the subframe to relax.

6

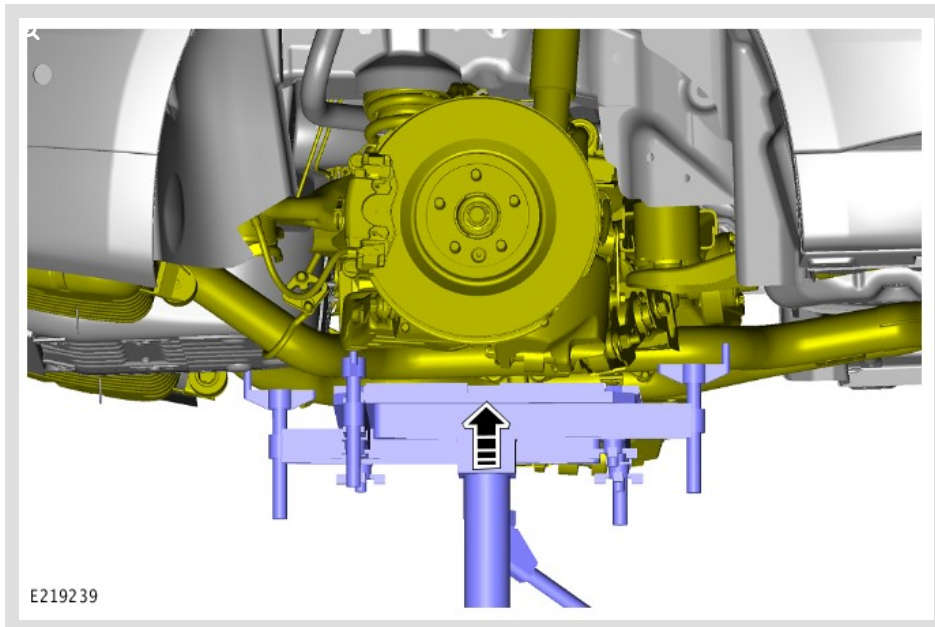

Use the transmission jack to raise the subframe into the correct position.

7

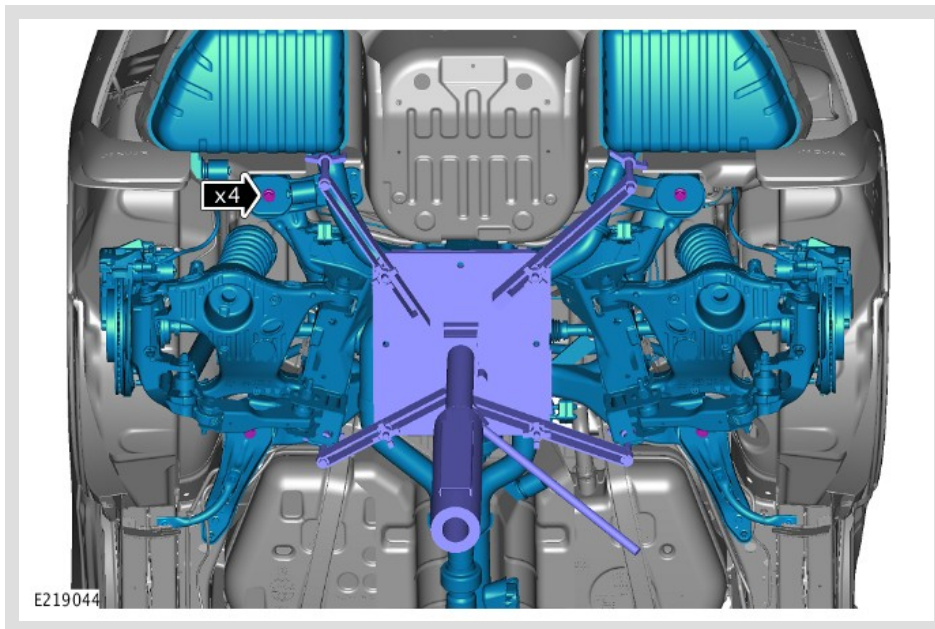

Install the 4 new subframe retaining bolts but do not tighten fully at this time.

8

**NOTE:**

Do not remove the alignment equipment until Step 10.

Complete a 4-wheel alignment inspection/adjustment (see TOPIx Workshop Manual section 204-00: Suspension System - General Information - General Procedures - Four wheel alignment).



9

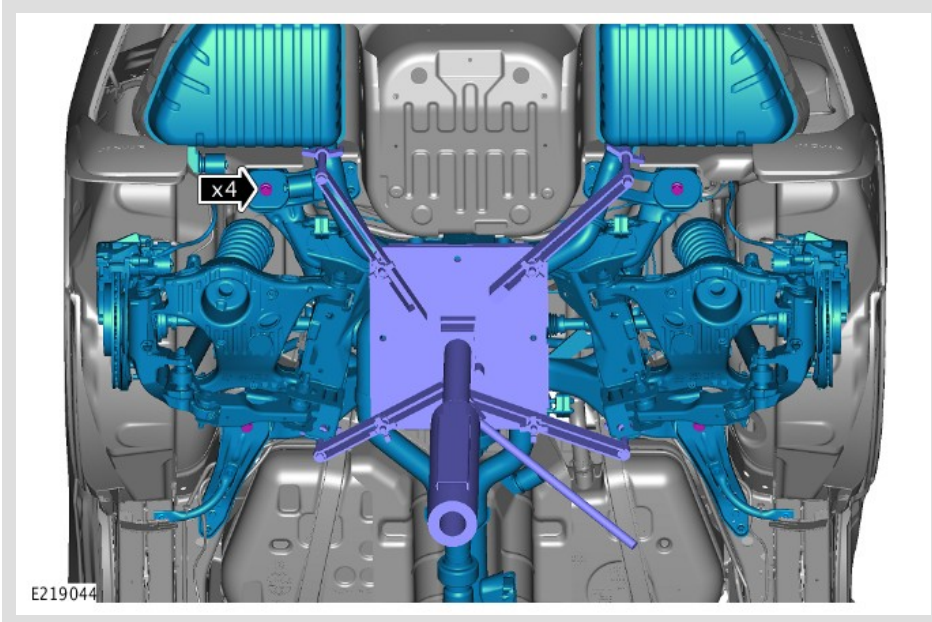

Tighten the subframe retaining bolts.

- Torque: **170 Nm.**

10

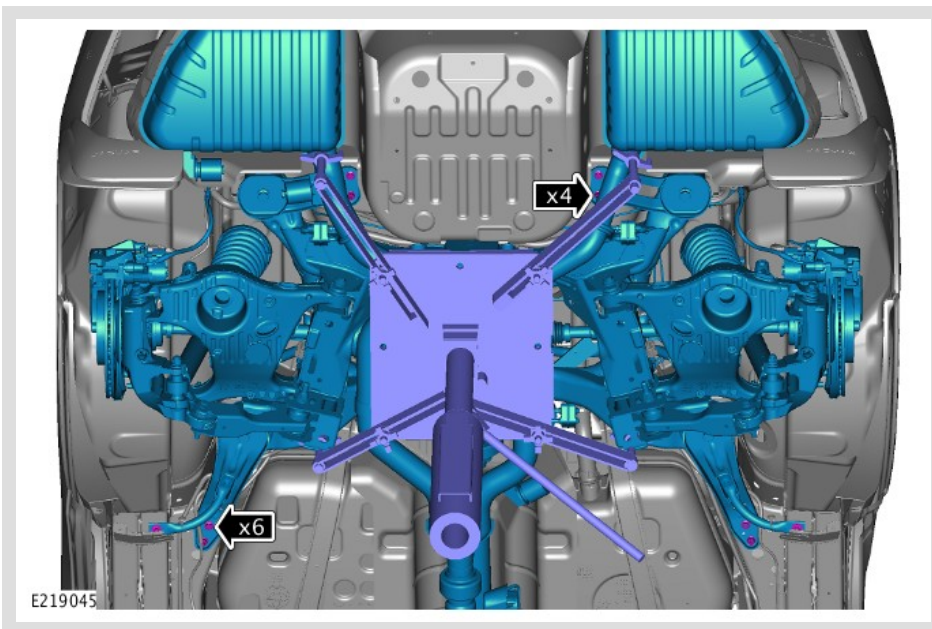

Tighten the subframe support plate retaining bolts (6) and nuts (4).

- Torque:
  - M8 - **25 Nm.**
  - M10 - **60 Nm.**

- 1 Verify alignment settings have not changed.
- 2 Remove the alignment equipment.

11

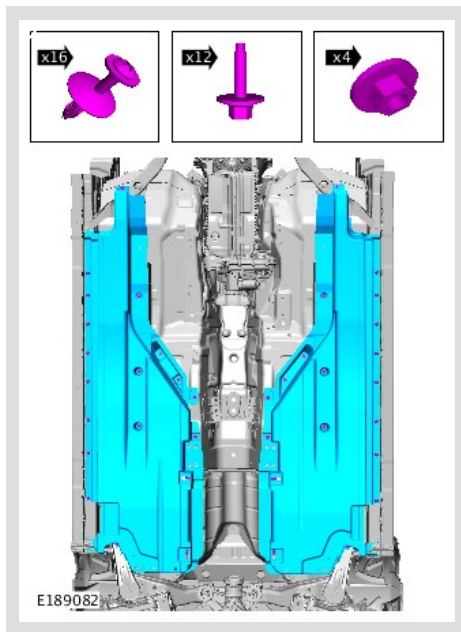

Install the left and right undershields.

12 Lower the vehicle.

13 Go to Workshop Procedure 'B'.

#### WORKSHOP PROCEDURE 'B':

1

#### ⓘ CAUTION:

Make sure the vehicle paintwork is not damaged when taking this measurement.

#### △ NOTES:

- Right shown; left similar.
- This Step must be performed to both sides of the vehicle/tailgate.

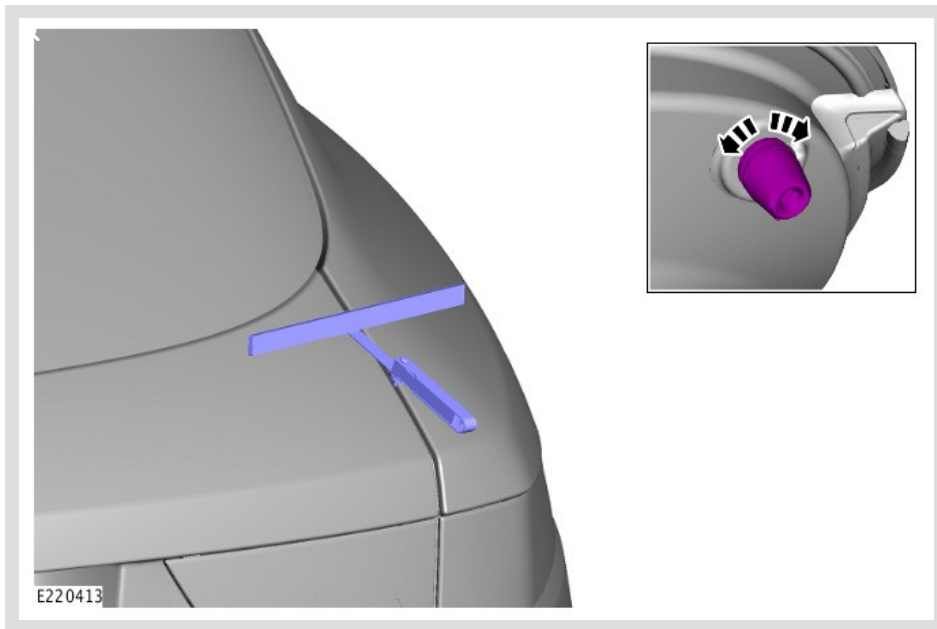

Use a suitable straight edge and a feeler gauge to set the tailgate alignment to 2.5 mm under flush.

1 Perform this step to the other side of the vehicle.

2 Perform a road test.

- If the customer concern is not present, release the vehicle.
- If the customer concern is present -
  - **V6 3.0L S/C engine:** go to Workshop Procedure 'D'.
  - **Ingenium I4 2.0L Diesel or Ingenium I4 2.0L Petrol engine:** go to Workshop Procedure 'C'.

#### WORKSHOP PROCEDURE 'C':

#### ⚠ WARNING:

Observe due care when working near a hot exhaust system.

#### △ NOTES:

- Some variation in the illustrations may occur, but the essential information is always correct.
- This procedure contains illustrations showing certain components removed to provide extra clarity.

**Vehicles with: Ingenium I4 2.0L Diesel or Ingenium I4 2.0L Petrol engine only.**

1 Open the hood.



2

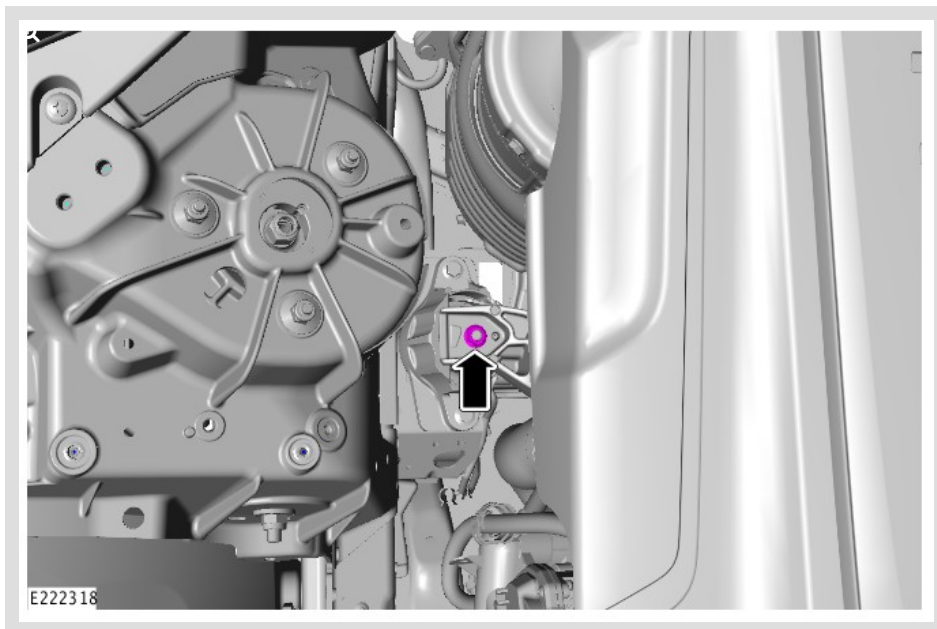

Loosen the right engine mount nut.

3

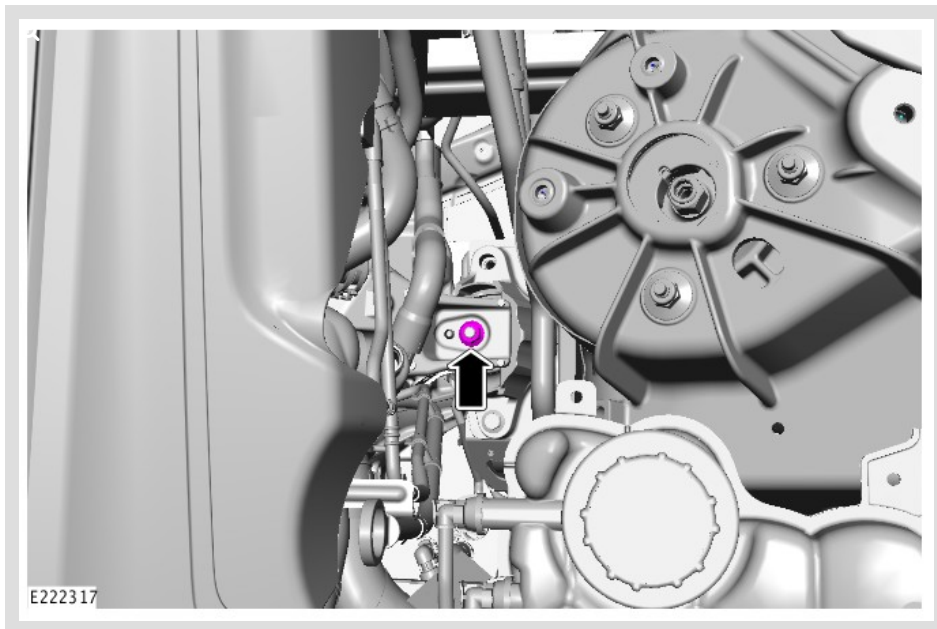

Loosen the left engine mount nut.

4 Raise the vehicle on a ramp (see TOPIx Workshop Manual section 100-02: Jacking and Lifting).

5

**⚠ WARNING:**

Observe due care when working near a hot exhaust system.

**△ NOTE:**

Vehicles with: Ingenium I4 2.0L diesel engine only.

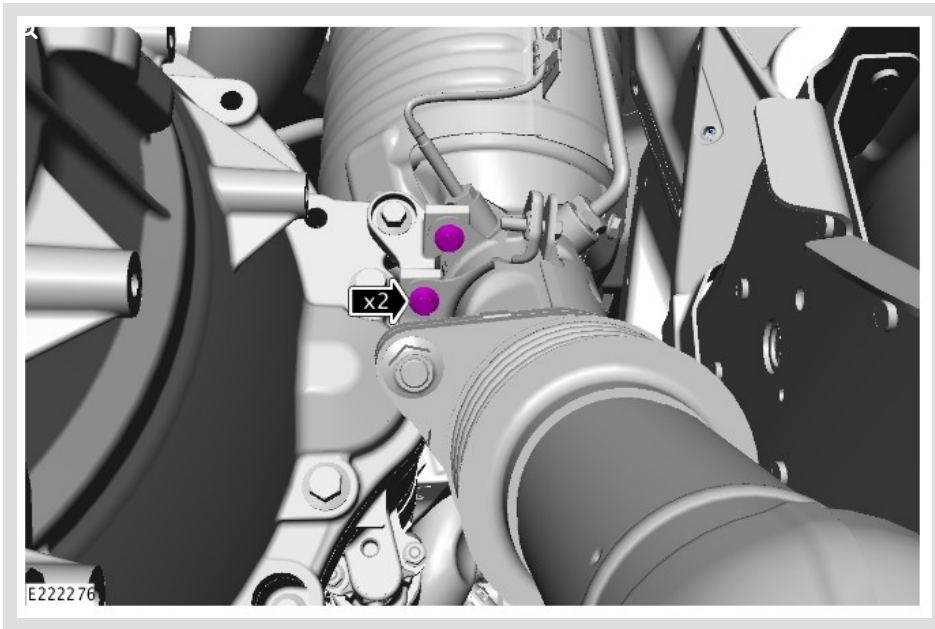

Loosen the 2 Diesel Particulate Filter (DPF) fasteners.

6

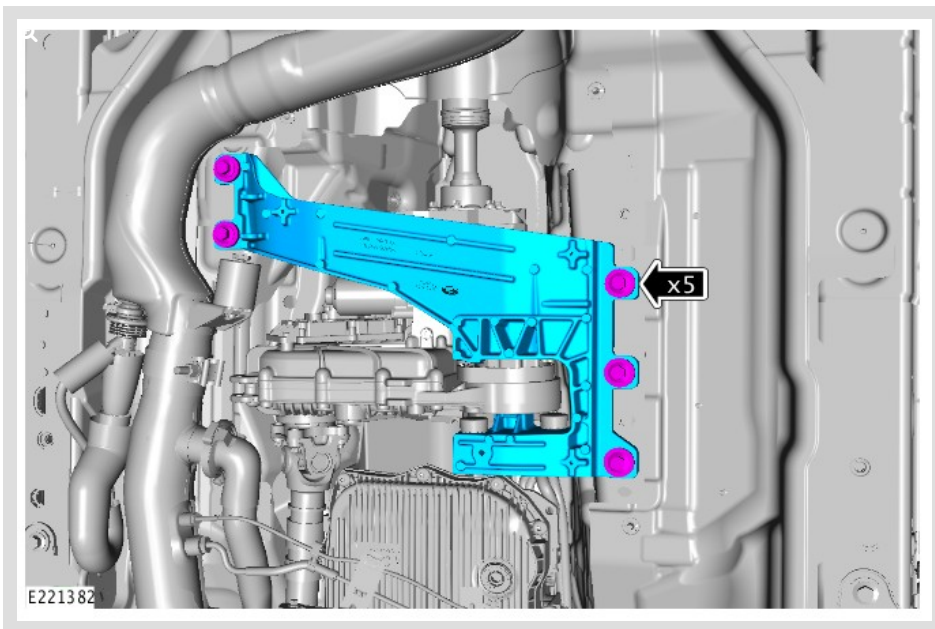

Loosen the 5 transmission mount fasteners.

7

**⚠ WARNING:**

Observe due care when working near a hot exhaust system.

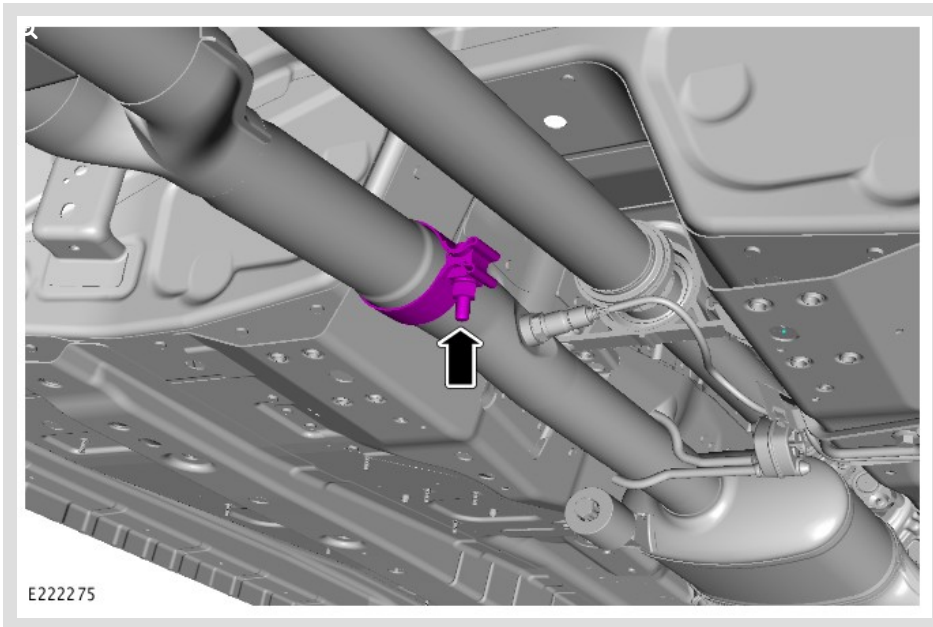

Loosen the exhaust clamp.

8 Lower the vehicle on the ramp (see TOPIx Workshop Manual section 100-02: Jacking and Lifting).

9 Align the exhaust system:

- 1 Start and stop the engine 4 times.
- 2 Start the engine.
- 3 Raise the engine RPM to between 3,500RPM and then let the engine speed drop to idle.
  - Repeat this step 5 additional times.
- 4 Stop the engine.
- 5 Start and stop the engine 5 times.

10

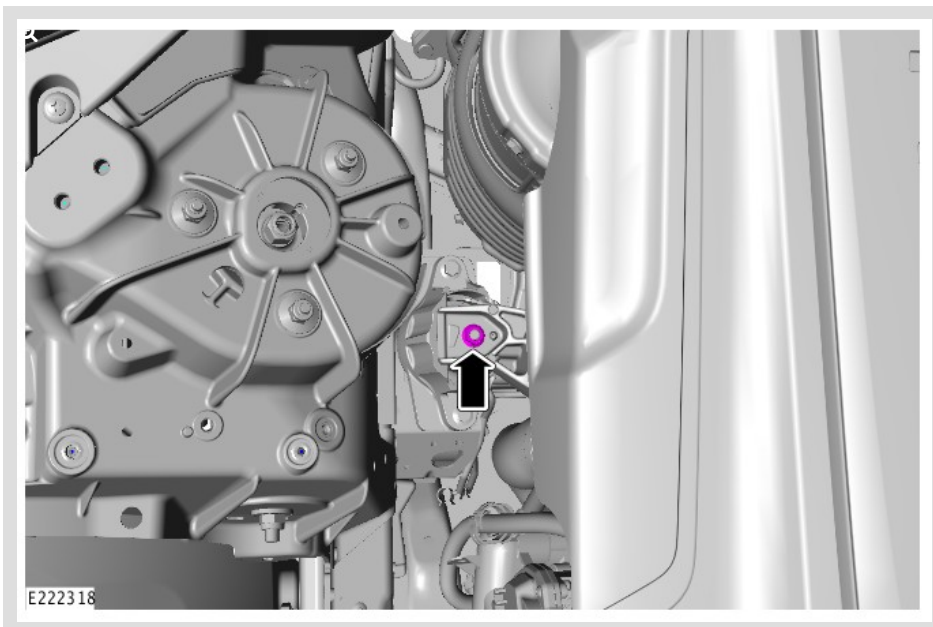

Tighten the right engine mount.

- Torque: **60 Nm**

11

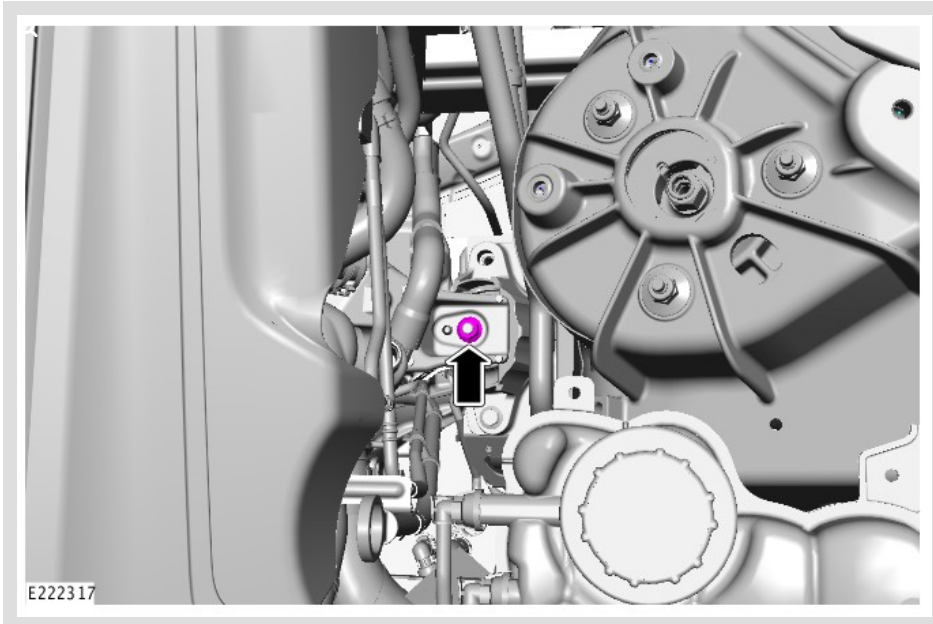

Tighten the left engine mount.

- Torque: **60 Nm**

12 Raise the vehicle on the ramp (see TOPIx Workshop Manual section 100-02: Jacking and Lifting).

13

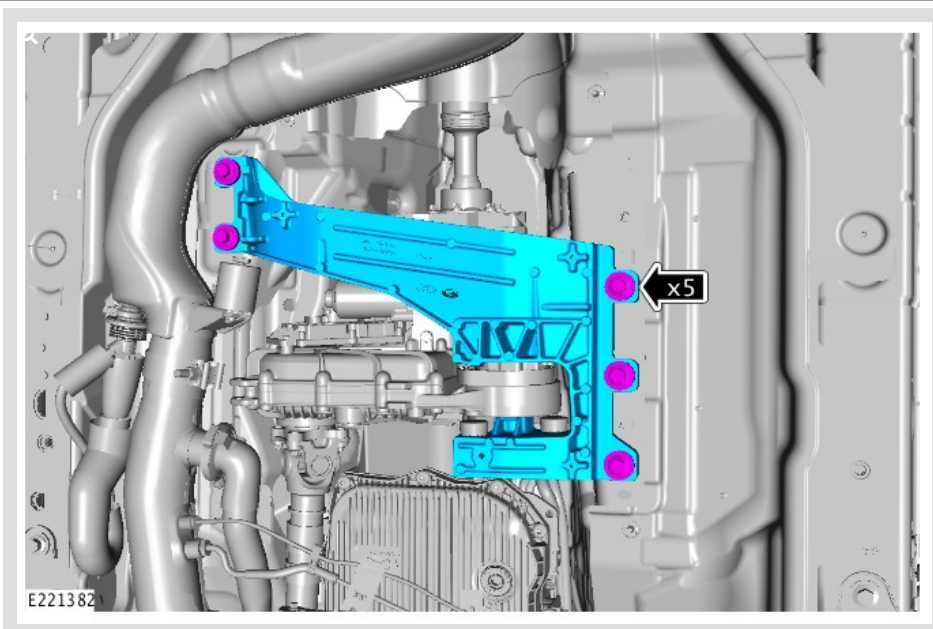

Tighten the 5 transmission mount fasteners.

- Torque: **60 Nm**

14

**⚠ WARNING:**

Observe due care when working near a hot exhaust system.

**△ NOTE:**

Vehicles with: Ingenium I4 2.0L diesel engine only.



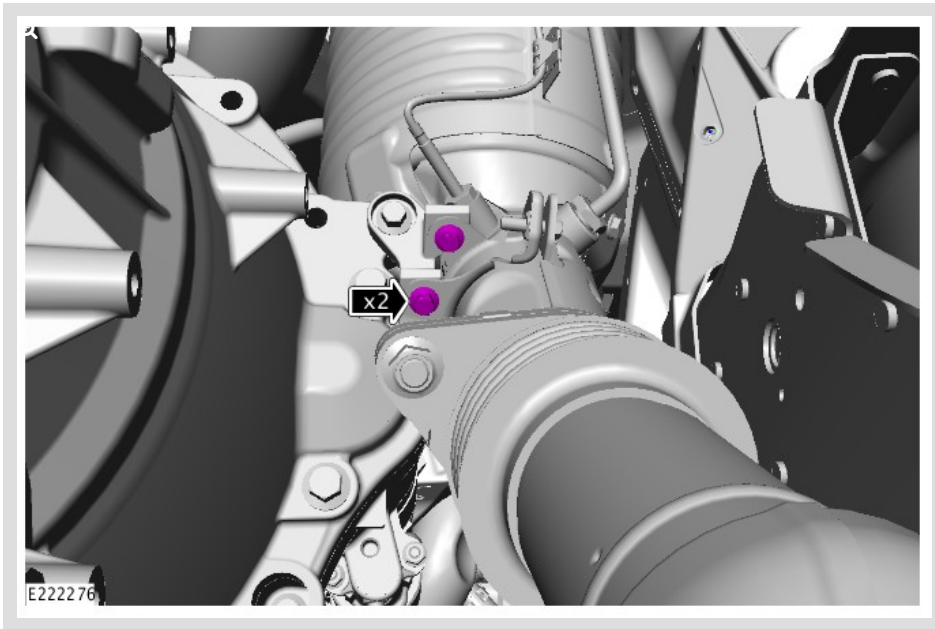

Tighten the 2 DPF fasteners.

- Torque: **25 Nm**

15

**⚠ WARNING:**

Observe due care when working near a hot exhaust system.

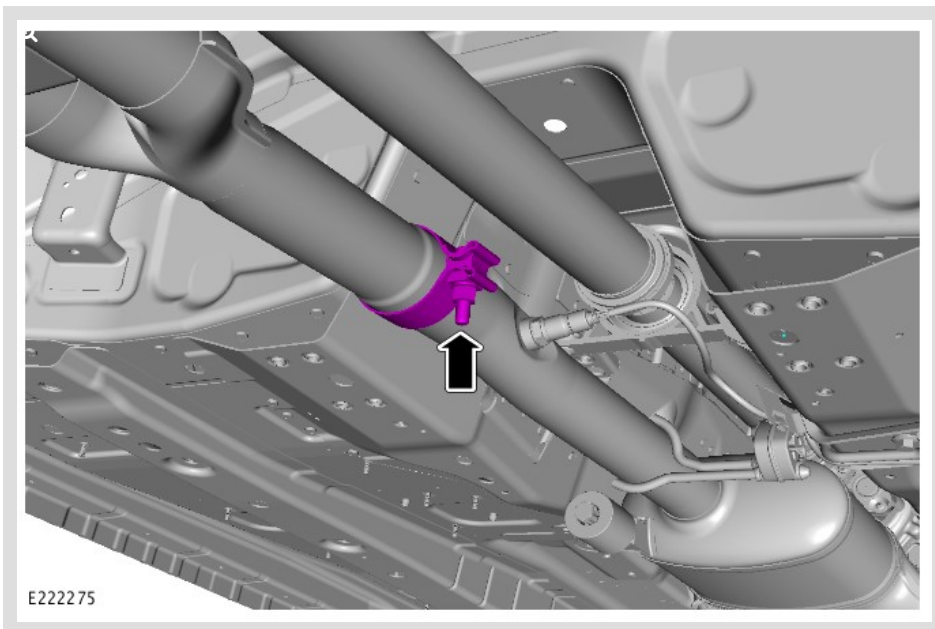

Tighten the exhaust clamp.

- Torque: **55 Nm**

16 Lower the vehicle (see TOPIx Workshop Manual section 100-02: Jacking and Lifting).

17 Close the hood.

18 Perform a road test.



- 1 If the customer concern is not present, release the vehicle.
- 2 If the customer concern is present, submit a Technical Assistance (TA) request for further assistance.

**WORKSHOP PROCEDURE 'D':****⚠ WARNING:**

Observe due care when working near a hot exhaust system.

**△ NOTES:**

Some variation in the illustrations may occur, but the essential information is always correct.

This procedure contains illustrations showing certain components removed to provide extra clarity.

**Vehicles with: V6 3.0L S/C Petrol engine only.**

- 1 Raise and support the vehicle (see TOPIx Workshop Manual section 100-02: Jacking and Lifting).
- 2 Remove the air deflector (see TOPIx Workshop Manual section 501-02: Front End Body Panels - Air Deflector).

**3 ⚠ WARNING:**

Observe due care when working near a hot exhaust system.

**△ NOTE:**

Perform this step on both sides.

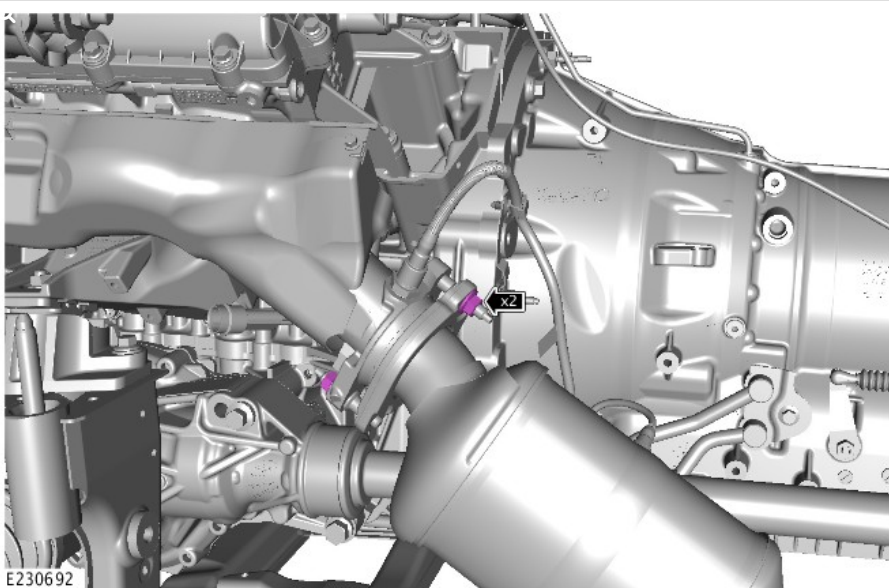

Loosen the 2 bolts.

4

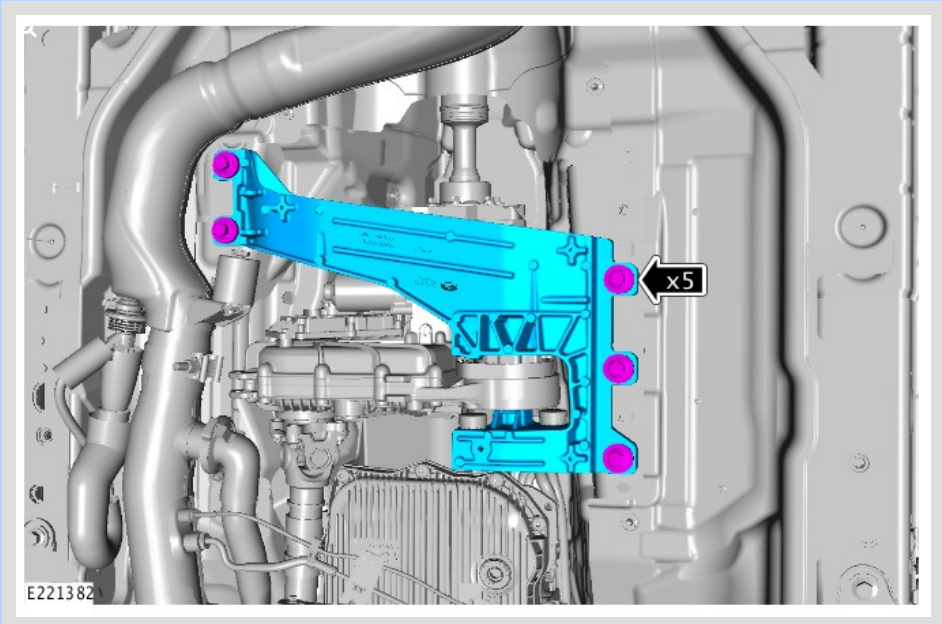

Loosen the 5 transfer case support bracket fixings.

5

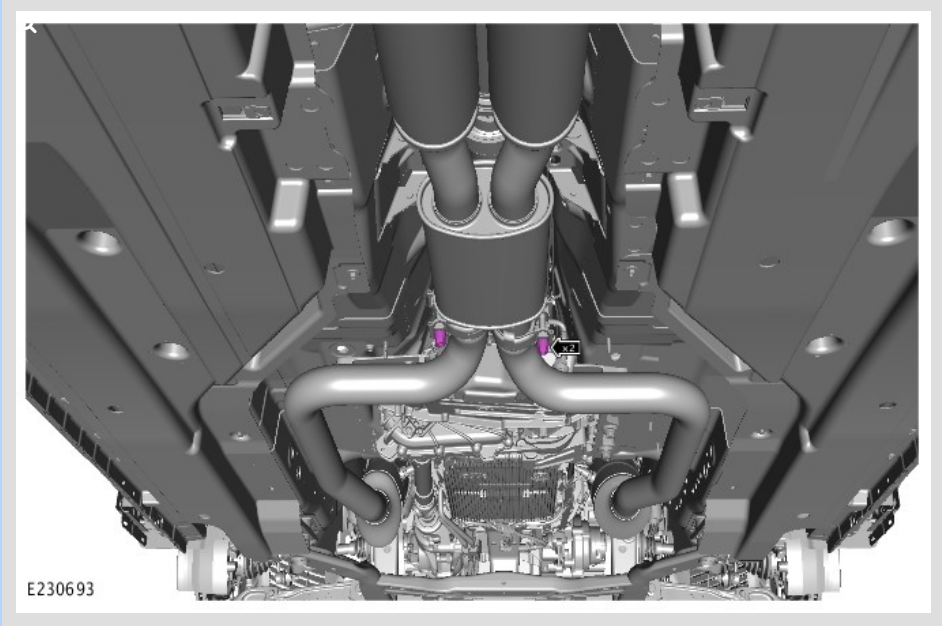

Loosen the 2 bolts.

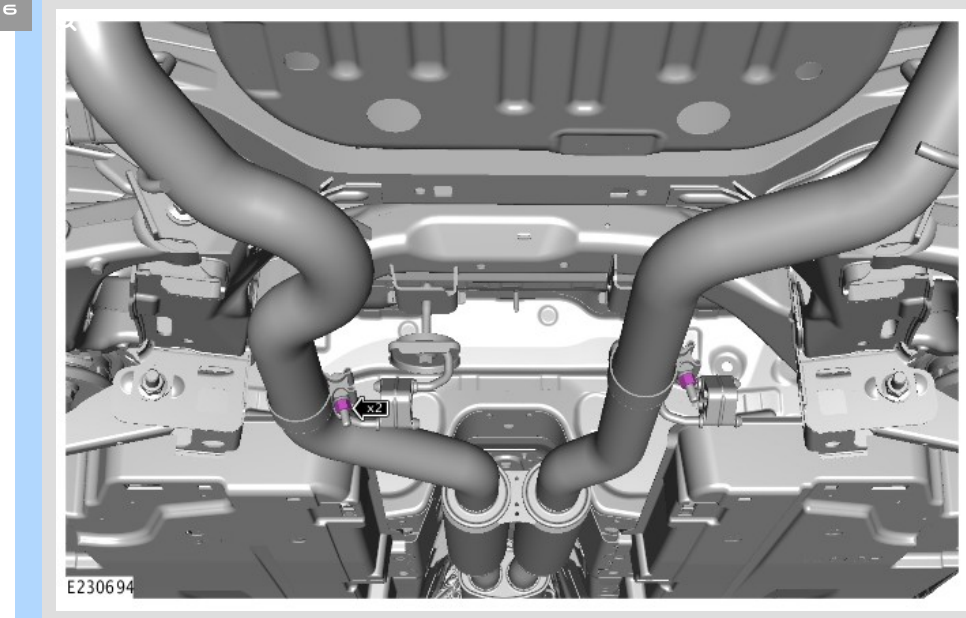

Loosen the 2 bolts.

7 To align the exhaust, follow the steps below.

- 1 Start and stop the engine 3 times.
- 2 Start the engine.
- 3 Raise the engine RPM to between 3,500RPM and then let the engine speed drop to idle.
  - Repeat this step 5 additional times.
- 4 Stop the engine.
- 5 Start and stop the engine 5 times.

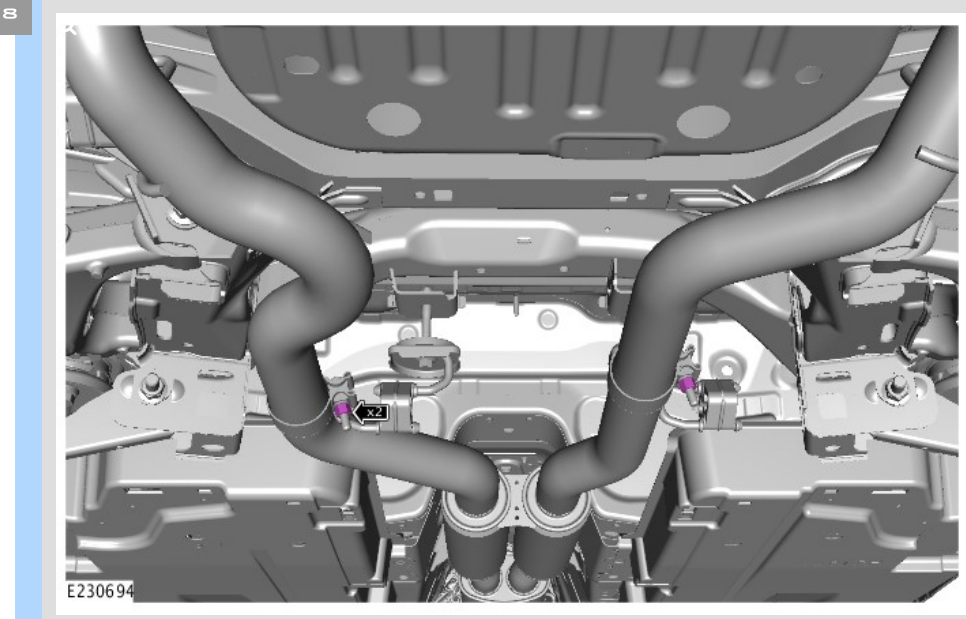

Tighten the 2 bolts.

- Torque: 55 Nm

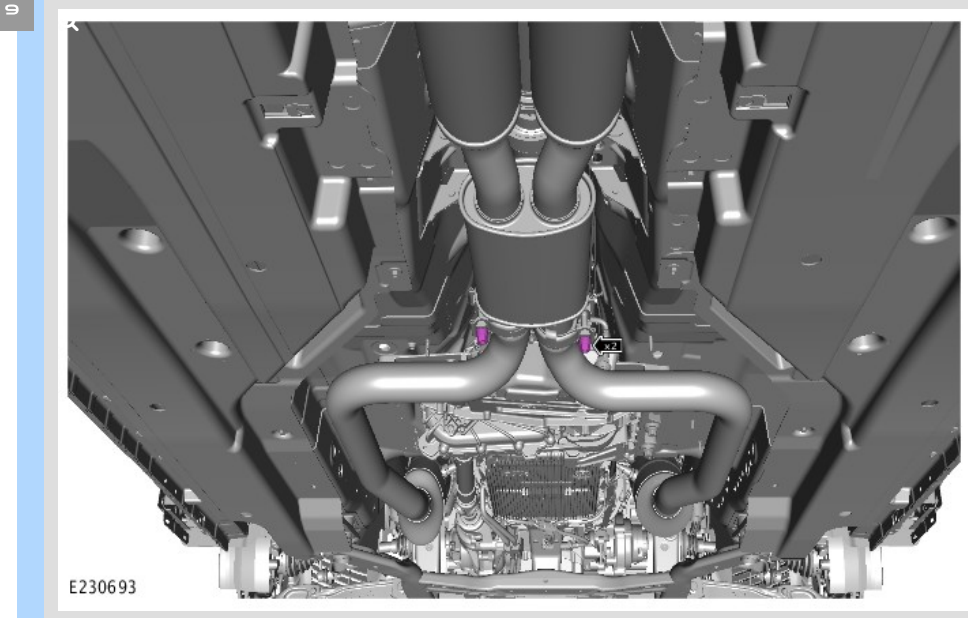

Tighten the 2 bolts.

- Torque: 55 Nm

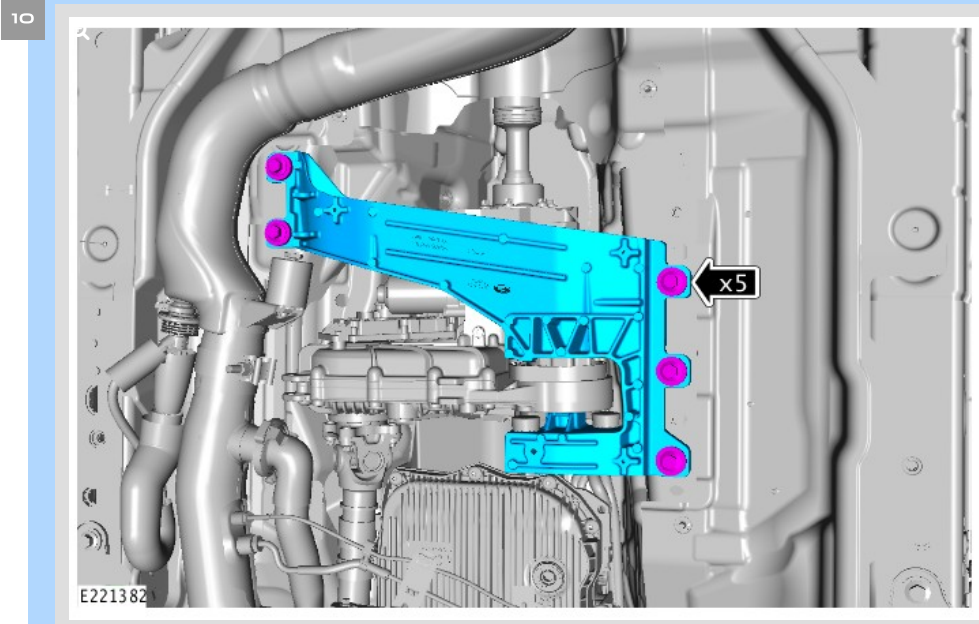

Tighten the 5 transfer case support bracket fixings.

- Torque: 60 Nm

11 **NOTE:**

Perform this step on both sides.

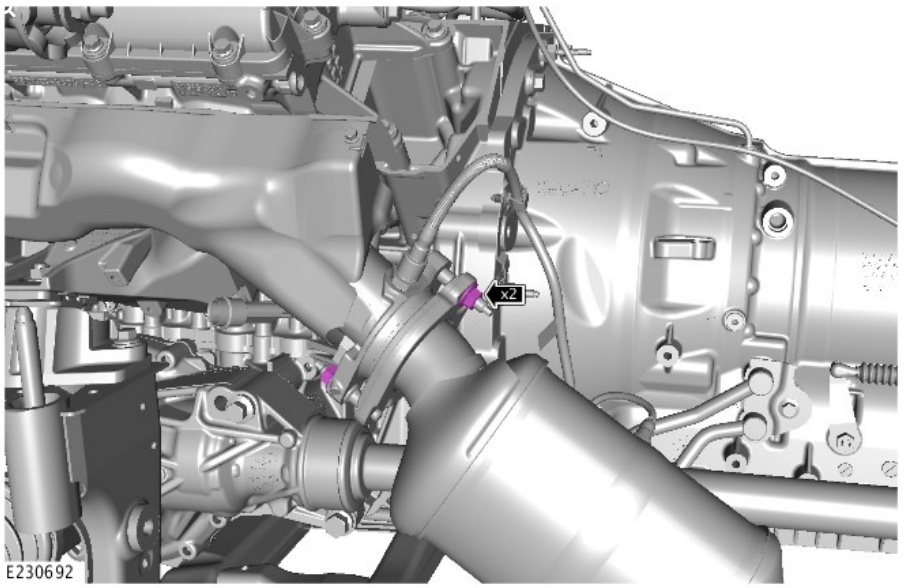

Tighten the 2 bolts.

- Torque: **40 Nm**

12 Install the air deflector (see TOPIx Workshop Manual section 501-02: Front End Body Panels - Air Deflector).

13 Lower the vehicle (see TOPIx Workshop Manual section 100-02: Jacking and Lifting).

14 Perform a road test.

- If the customer concern is not present, release the vehicle.
- If the customer concern is present, submit a Technical Assistance (TA) request for further assistance.