



## Preliminary Information

### PIT5359C Radio Back Lighting Stays on After Key Off / Dead Battery / TCCM Repeat Failure

#### Models

Brand:	Model:	Model Years:	VIN:		Engine:	Transmissions:
			from	to		
Chevrolet	Silverado 1500	2014	All	All	All	All
Chevrolet	Silverado	2015 - 2018	All	All	All	All
Chevrolet	Silverado LD	2019	All	All	All	All
Chevrolet	Silverado 2500/3500	2019	All	All	All	All
GMC	Sierra 1500	2014	All	All	All	All
GMC	Sierra	2015 - 2018	All	All	All	All
GMC	Sierra Limited	2019	All	All	All	All
GMC	Sierra 2500/3500	2019	All	All	All	All

#### Supersession Statement

This PI was superseded to update Model Years. Please discard PIT5359B.

With Transfer Case (RPO NQF or NQH)

The following diagnosis might be helpful if the vehicle exhibits the symptom(s) described in this PI.

#### Condition / Concern

**Some owners many comment that their radio backlighting will stay on even after the ignition has been turned off and the key has been removed for several minutes. Eventually, the battery will go dead. While diagnosing the concern, voltage may be present at the following fuses with the ignition key in the off position: F23DL F22DL F30DL F31DL F32DL (reference SI Doc ID 3819053). These fuses are all on the same Run/Crank Ignition Buss Bar, in the Left I/P Fuse Block, and should not have any power with the ignition off. In some cases, there may only be 2 or 3 volts present, so a voltmeter must be used to check for voltage.**

**This could be caused by the TCCM back feeding voltage into the fuse block with the ignition off. If the TCCM is disconnected, the voltage at the fuses will be gone. If the TCCM is replaced, the issue may only be corrected for a short time. The internal circuitry of the TCCM may have been permanently damaged by a voltage spike, causing the back feed.**

**In most cases, the voltage spike is caused by an aftermarket accessory, which utilizes a solenoid or relay, that is wired onto the F30DL fuse or to the X61A I/P Junction Block connector X7 terminal 11 or connector X5 terminal 35. If these solenoids or relays are not properly suppressed, they will produce a voltage spike. The voltage spike can be transmitted onto the Run/Crank Ignition Buss Bar and permanently damage the TCCM.**

#### Recommendations / Instructions

**Important: DO NOT** replace the TCCM until the root cause of the condition has been narrowed to the solenoid/relay voltage spikes.

To prevent damage to any of the sensitive electronic components on the bussed circuit, the solenoid/relay **MUST** have the control circuit suppressed with a diode. The diode will prevent the voltage spikes from being transmitted onto the Run/Crank circuit.

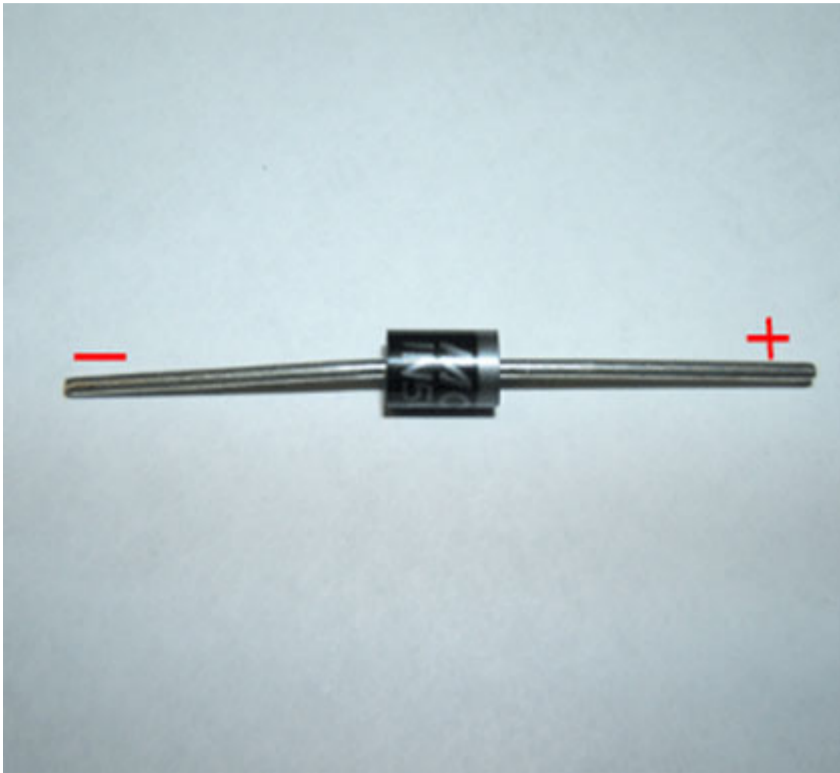

Install a diode, P/N 12112422, across the coil of the solenoid. It is important that the striped end of the diode be connected to the positive terminal of the coil and the other end of the diode be connected to ground.



**Important: Be sure to insulate the diode with heat shrink tubing before installing as shown in the picture above.**

**Notice:** Some solenoids/relays may only have a positive post and will get their ground through their mounting bracket. In this case, the striped end of the diode is to be connected to the positive terminal and other end should be connected to the ground of the solenoid/relay.

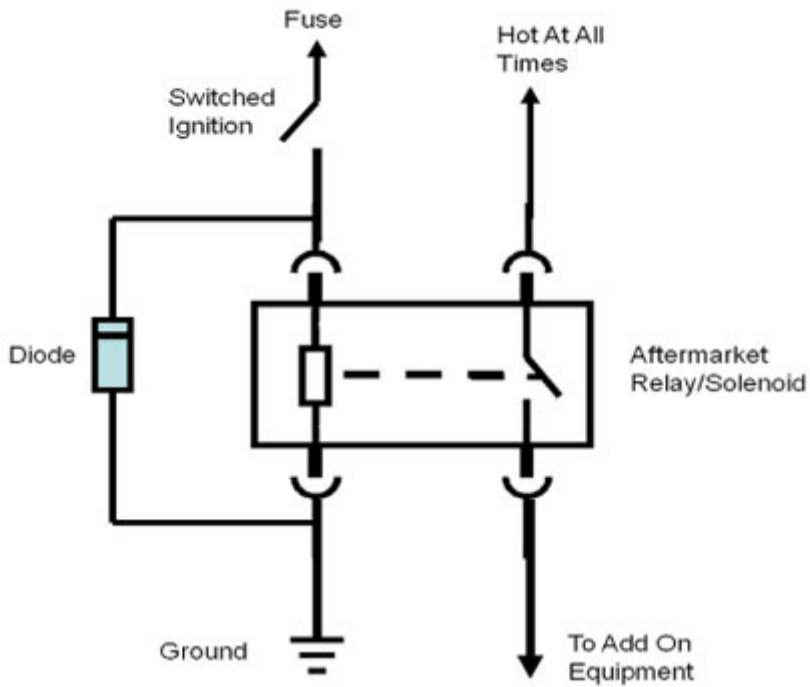

**Install a diode, P/N 12112422, across the coil of the relay. It is important that the striped end of the diode be connected to the positive terminal of the coil and the other end of the diode be connected to ground. Be sure to insulate the diode with heat shrink tubing before installing.**

Parts Information

Part Number	Description	Qty
12112422	Diode	1

Warranty Information

**This repair will not be covered under warranty due to the failure being caused by an aftermarket accessory.**

Please follow this diagnostic or repair process thoroughly and complete each step. If the condition exhibited is resolved without completing every step, the remaining steps do not need to be performed.

