

FLA COE
FLB COE
FLD Conventional
Business Class
FLC 112 Conventional

Century Class Conventional
Argosy COE
Cargo
Columbia
> 122SD and Coronado

> Business Class M2
> Cascadia
> 108SD/114SD
New Cascadia

Freightliner
Service Bulletin

General Information

With the start of production on February 12, 2018, the fasteners used to assemble Airliner rear suspension crossmembers changed. The forward-suspension crossmember will be assembled with 5/8–18 fasteners and the rear-suspension (bogie) crossmember will be assembled with 3/4–16 fasteners. This change also includes a revision to a higher friction nut which requires an increase in tightening torque. The new higher friction nut can be identified by its green color. See [Fig. 1](#). Green fasteners are standard. If the crossmember mounting hardware is being removed replace with new hardware per the part numbers in PartsPro.

Tighten the forward-suspension crossmember 5/8–18 fasteners from the bolt head to 181 ± 13 lbf-ft (245 ± 17 N·m). See [Fig. 2](#).

Tighten the rear-suspension (bogie) crossmember 3/4–16 fasteners from the bolt head to 266 ± 19 lbf-ft (360 ± 25 N·m). See [Fig. 2](#).



Fig. 1, New High Friction Nut

Freightliner Service Bulletin

FLA COE
FLB COE
FLD Conventional
Business Class
FLC 112 Conventional

Century Class Conventional
Argosy COE
Cargo
Columbia
> 122SD and Coronado

> Business Class M2
> Cascadia
> 108SD/114SD
New Cascadia

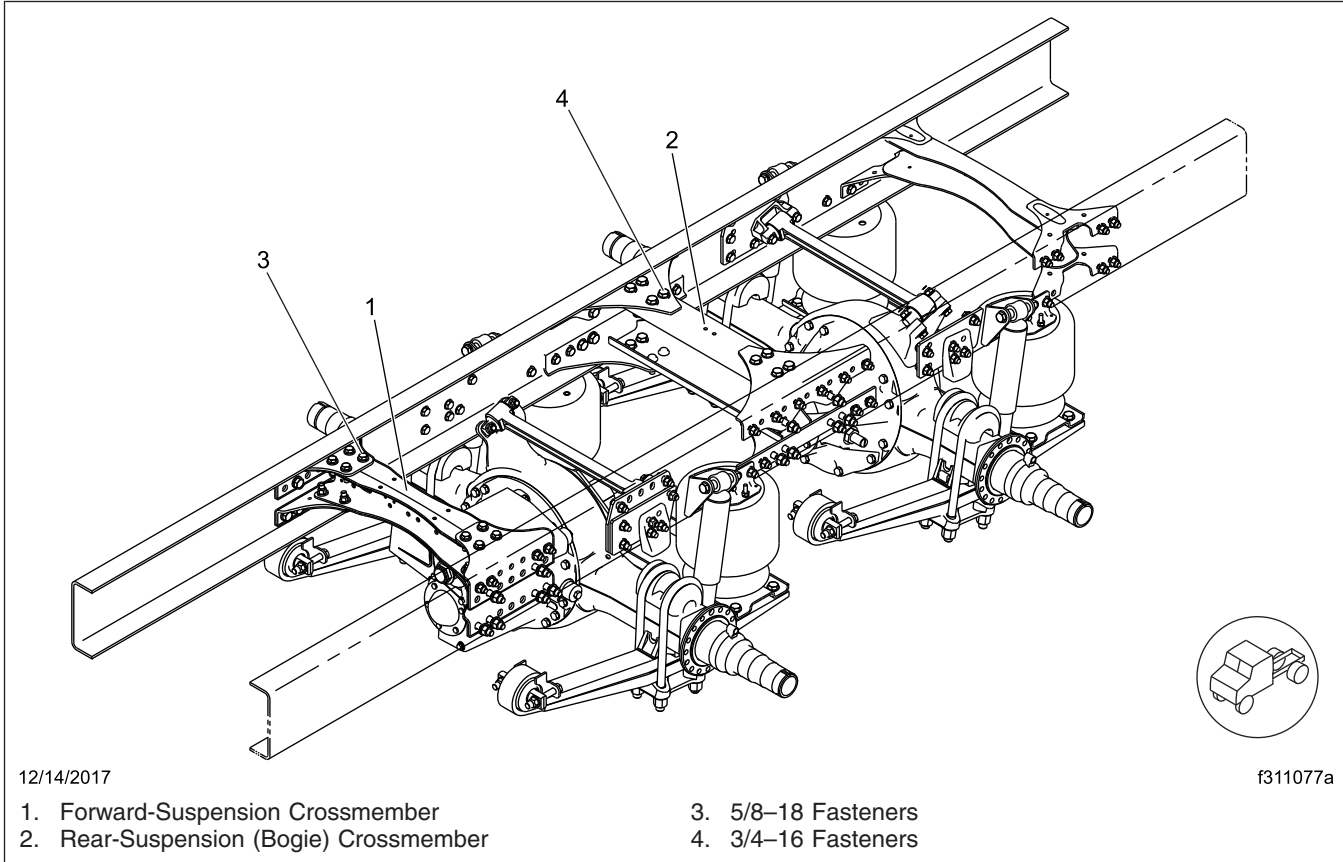

Fig. 2, Rear Suspension Crossmember Fasteners

The new fasteners are available from the PDC's. See [Table 1](#) and [Table 2](#).

Forward-Suspension Crossmember Replacement Fasteners		
Part Number	Description	Qty
23-09445-200	SCREW-CAP,HEX5/8-18X2,GR8PO	16
23-14450-210	NUT-HEX,LKG,ZNAL,.62-18	16
23-09114-000	WASHER-HRDN,0.69X1.31X.177	32

Table 1, Forward-Suspension Crossmember Replacement Fasteners

Rear-Suspension (Bogie) Crossmember Replacement Fasteners		
Part Number	Description	Qty
23-13272-175	CAP SCR/BOLT 3/4-16 UNF GR8/8	16
23-14450-212	NUT-HEX,LKG,ZNAL,.75-16	16
23-09114-004	WASHER-HRDN,0.81X1.47X.177,ZN	32

Table 2, Rear-Suspension (Bogie) Crossmember Replacement Fasteners

FLA COE
FLB COE
FLD Conventional
Business Class
FLC 112 Conventional

Century Class Conventional
Argosy COE
Cargo
Columbia
> 122SD and Coronado

> Business Class M2
> Cascadia
> 108SD/114SD
New Cascadia

**Freightliner
Service Bulletin**

Warranty

This is an information bulletin only. Warranty does not apply.

