

October 10, 2018

Version 1

## ZDX Front Passenger's Airbag Inflator Inspection

### AFFECTED VEHICLES

| Year    | Model | Trim | VIN Range                                |
|---------|-------|------|--|
| 2010-13 | ZDX   | ALL  | Check the iN VIN status for eligibility. |

### BACKGROUND

American Honda is conducting an inspection of certain vehicles that have previously had the passenger's airbag inflator replaced as part of the Takata Passenger's Airbag Inflator recall.

### CORRECTIVE ACTION

Inspect the front passenger airbag inflator and, if the inflator is not installed correctly, replace the airbag module assembly.

#### NOTES

These notes are applicable only when the airbag assembly is replaced:

- Write the serial number and part number from the side of the new replacement front passenger's airbag module box on the repair order.
- To properly dispose of the original inflator, you must remove it from the airbag module. See REMOVE THE INFLATOR FROM THE ORIGINAL AIRBAG MODULE.
- A new inflator box must be ordered and the original inflator must be returned in the box.
- To return the inflator, follow the shipping instructions outlined in the parts information bulletin B15-0006, Inflator Kit Return Process.
- Place the original airbag module (without the inflator) in the airbag module box that the replacement came in. **It may be called in by American Honda.**
- Two photos are required to submit a warranty claim:
  - The inflator incorrectly installed.
  - The original airbag module serial number.

### PARTS INFORMATION

#### Inspection Only

| Part Name               | Part Number   | Quantity |
|-------------------------|---------------|----------|
| Washer Bolt (6 x 16 mm) | 90178-STX-003 | 2        |

**CLIENT INFORMATION:** The information in this bulletin is intended for use only by skilled technicians who have the proper tools, equipment, and training to correctly and safely maintain your vehicle. These procedures should not be attempted by "do-it-yourselfers," and you should not assume this bulletin applies to your vehicle, or that your vehicle has the condition described. To determine whether this information applies, contact an authorized Acura automobile dealer.

| Part Name         | Part Number   | Quantity |
|-------------------|---------------|----------|
| Nut-Washer (6 mm) | 90321-SP0-A80 | 3        |

### Airbag Assembly Replacement

| Part Name   | Part Number                 |
|---|-----------------------------|
| Refer to the parts catalog using the VIN to ensure the correct airbag module and ancillary parts are ordered. | Refer to the parts catalog. |

- **Make sure the airbag inflator is removed from the original airbag module.** See *Remove the Inflator From the Original Airbag Module* section of this bulletin.
- The new airbag module box must be used to return the old airbag module **without the inflator** to American Honda (if requested). Be careful not to damage the airbag module box.
- To return the inflator, follow the shipping instructions outlined in the parts information bulletin B15-0006, *Inflator Kit Return Process*.
- Parts staff can scan the part number and serial number from the outside of the box into the warranty claim by using the Controlled Part Serial No. screen and scanning the applicable information. Refer to the Job Aid *Ordering and Managing Replacement Inflators* for more information.

### WARRANTY CLAIM INFORMATION

- To avoid non-payment of warranty claims for airbag module assembly replacement, the new airbag module part number and serial number must be included in each claim. For more information, refer to step 1 of AIRBAG MODULE INSTALLATION.
- To avoid a warranty claim being charged back to your dealership, follow the normal warranty part retention rules. American Honda may call in the original airbag module.
- The serial number is encoded into the bar code label attached to the outside of the box. If your dealership uses a scanner, you can scan the serial number into the claim.
- The part number is encoded into a barcode attached to the outside of the box. If your dealership uses a scanner, you can scan the part number into the claim.
- **If you confuse the serial number and part number when entering the claim information,** your claim will automatically be rejected.
- Template IDs are not included because there are many model/trim/color variations.
- If the airbag module is replaced, two photos are required to submit a warranty claim:
  - The inflator incorrectly installed.
  - The original airbag module serial number.

| Operation Number | Description   | Flat Rate Time | Defect Code | Symptom Code | Failed Part Number |
|------------------|---|----------------|-------------|--------------|--------------------|
| 7541A9           | ZDX Inspect the original airbag inflator installation.                    | 0.6 hr         | Z0400       | K2V00        | 77851-SZN-A30      |
| 7541G0           | ZDX - Inspect the inflator and <b>replace</b> the original airbag module. | 0.6 hr         | Z0400       | K2V00        | 77851-SZN-A30      |

Skill Level: Repair Technician

## INSPECTION PROCEDURE ZDX

### NOTE

If the VIN status inquiry indicates that the vehicle is subject to any open safety recalls, including a driver's airbag inflator campaign/recall, make sure to also complete those recall repairs before returning the vehicle to the client. If you are unable to complete any open recall, advise the client of the recall status and when the recall could be completed.

1. Open the glove box, and remove the passenger's dashboard trim.

#### 2010-11 ZDX

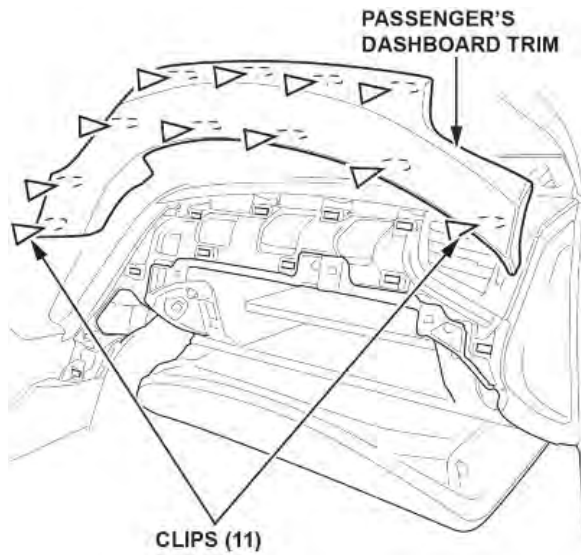

#### 2012-13 ZDX

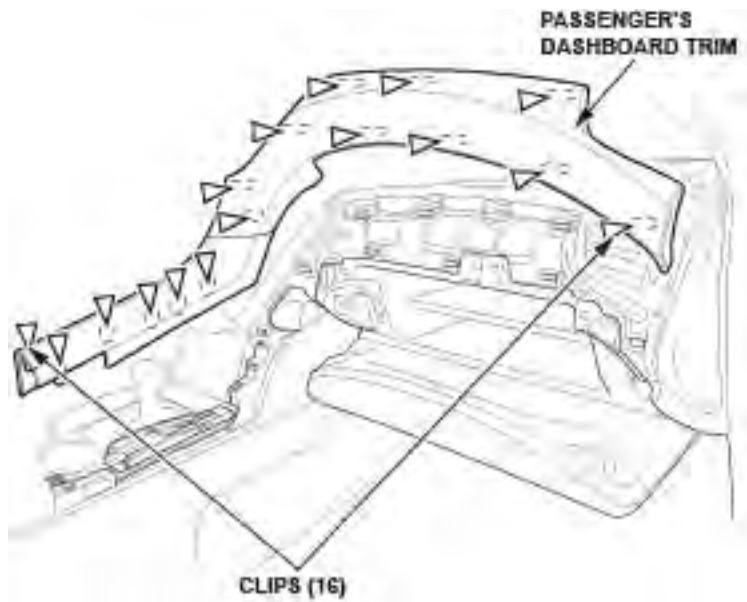

2. Remove the passenger's dashboard side panel.

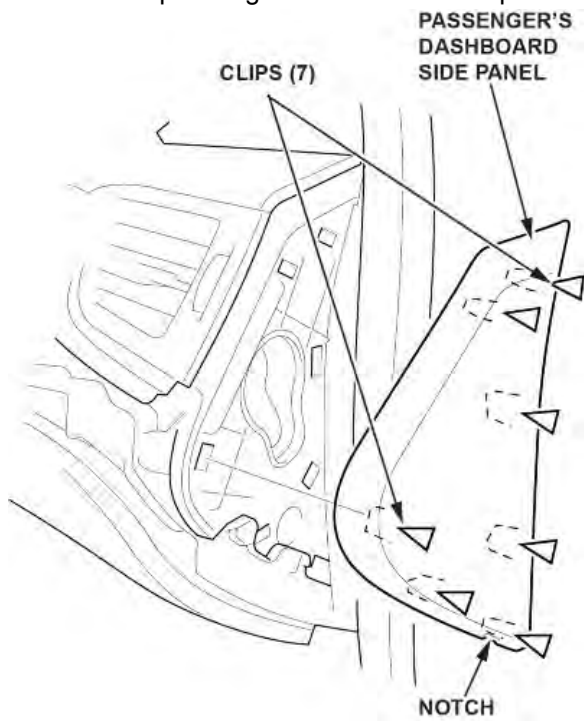

3. Remove the bolts and screws.

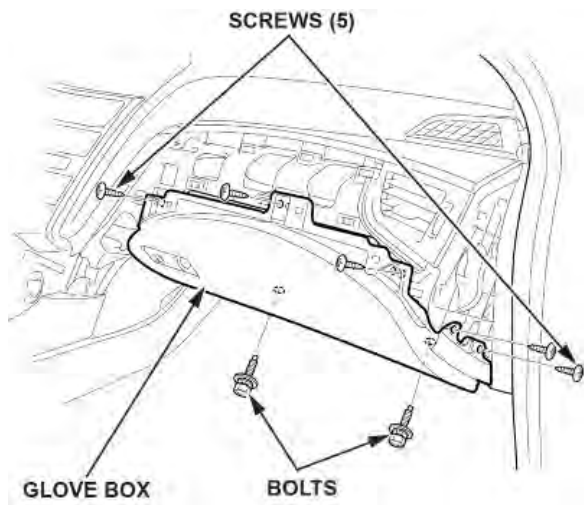

4. Release the hook and pull the glove box out to detach the clip.

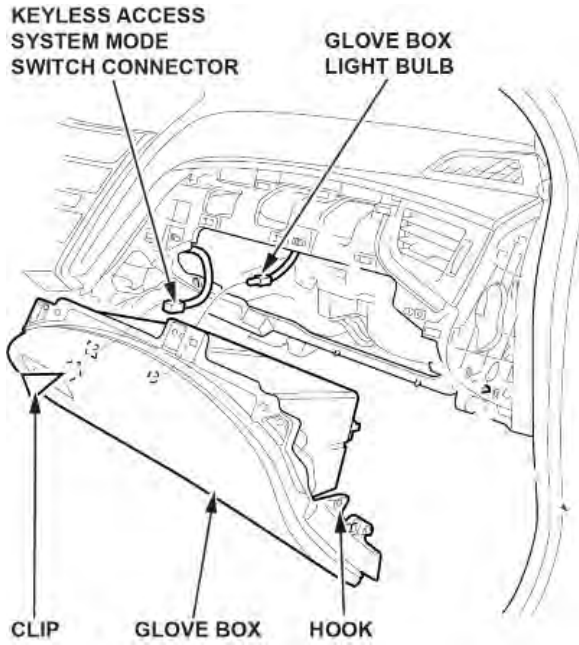

5. Disconnect the glove box light connector and the keyless access system mode switch connector (if equipped).
6. Remove the passenger's dashboard ducts by removing the screw.

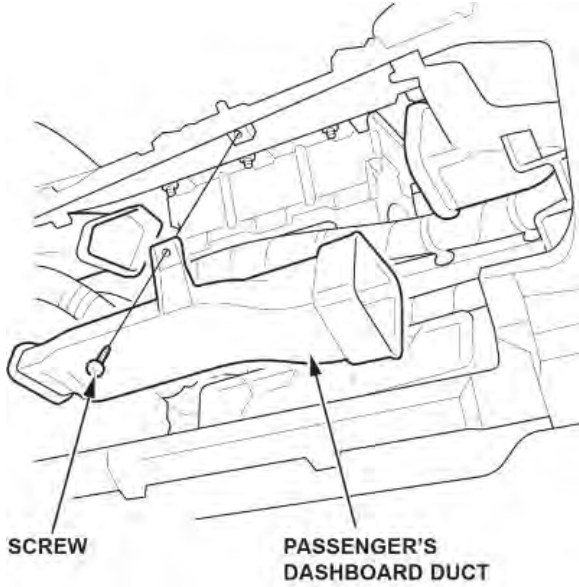

7. Detach the airbag harness clips. Pull down the wire harness, then disconnect the front passenger's inflator connector.

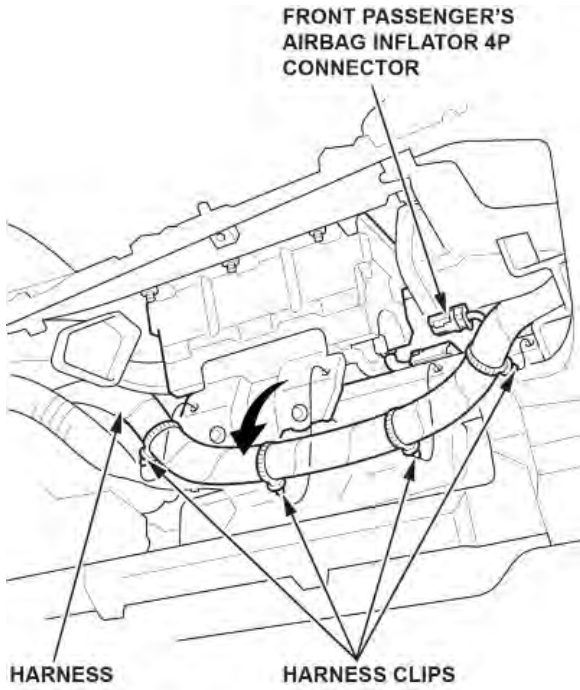

8. Remove the mounting nuts and mounting bolts from the front passenger's airbag.

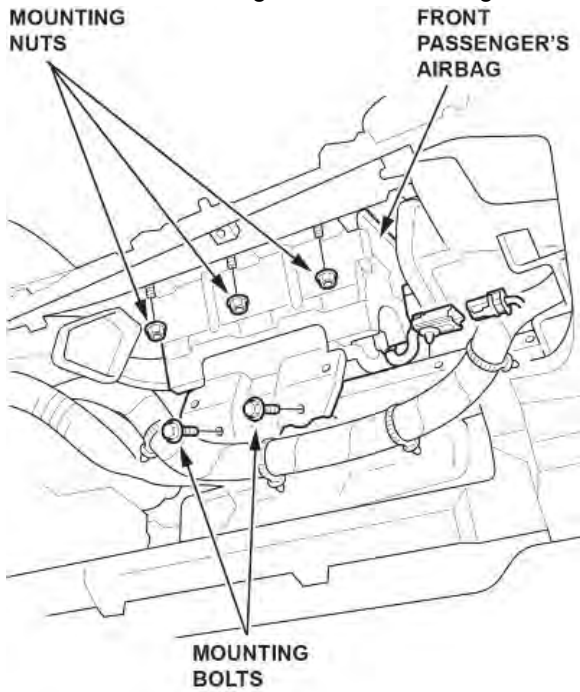

9. Release the pin and remove the front passenger's airbag.

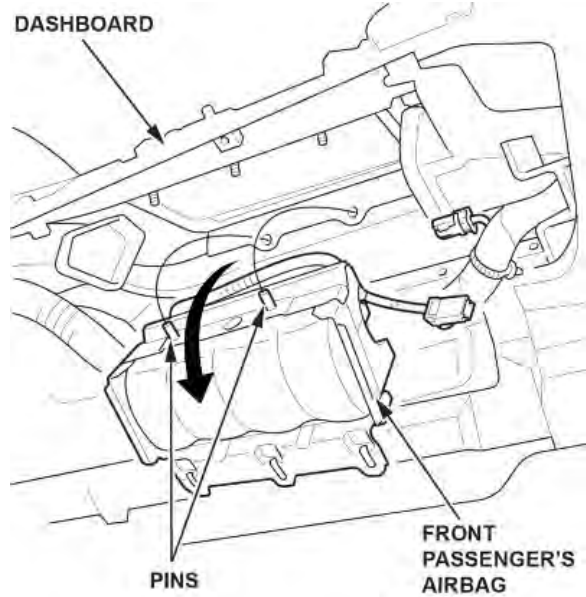

10. Place the airbag, face-down, on a clean shop towel with the mounting bracket facing toward you, and inspect the plastic collars on the passenger's airbag inflator.
- If the long collar is on your right side (closer to the driver's side when installed in the vehicle), the inflator installation is **GOOD**. Reassemble the glove box in the reverse order of removal.
  - If the long collar is on your left side (closer to the front passenger's door when installed in the vehicle), the inflator installation is **NO GOOD**. Go to AIRBAG MODULE REPLACEMENT PROCEDURE.

In addition, if the airbag is replaced, AHM requires two clear photos of the following to be submitted with your claim:

- The inflator incorrectly installed.
- The original airbag module serial number.

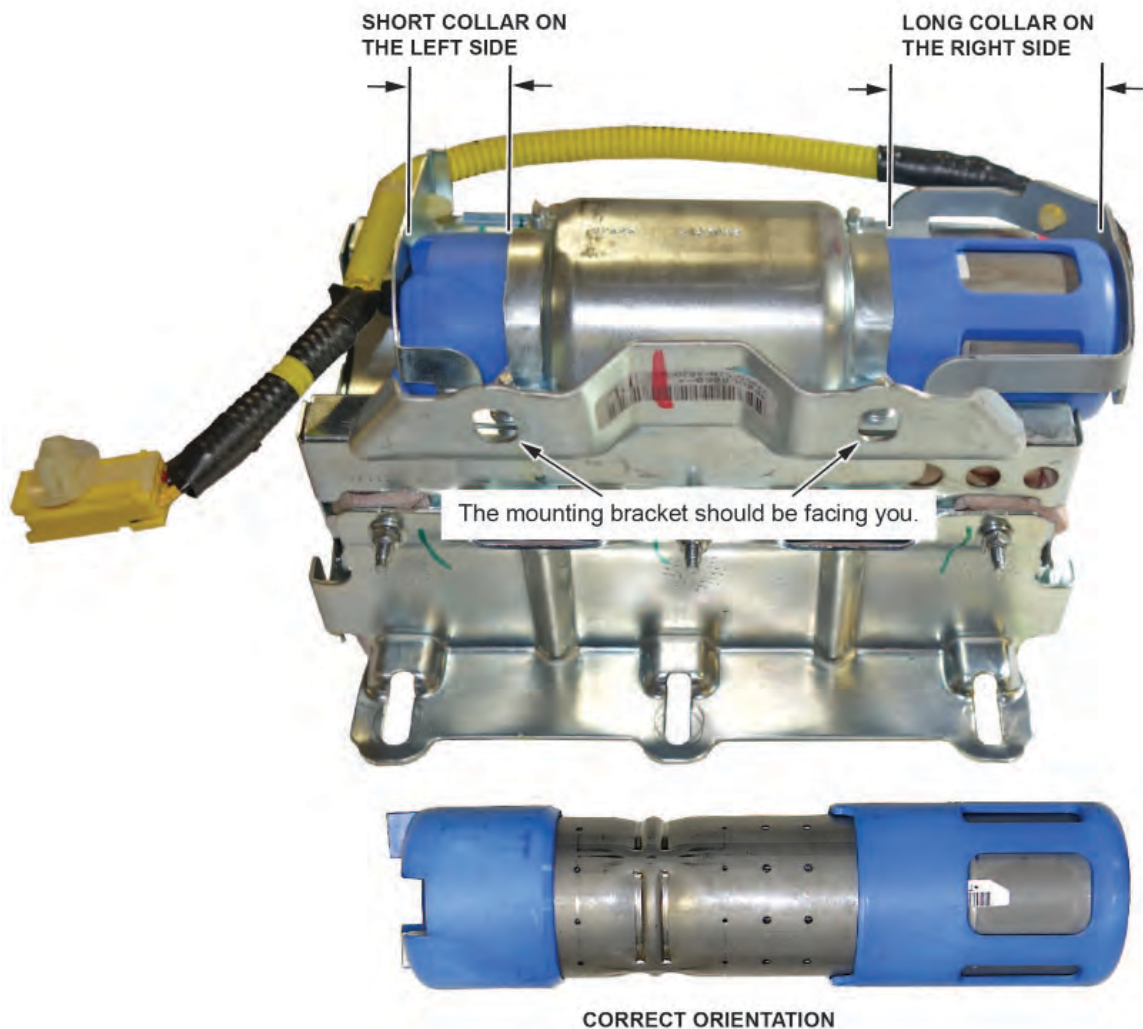



## AIRBAG MODULE INSTALLATION

1. **For airbag module replacement only** - Write the serial number and part number from the side of the new front replacement passenger's airbag module box on the RO. For the warranty claim to be paid, **the new front passenger's airbag module part number and serial number** must be included in the warranty claim.



2. Install the passenger's airbag module (assembly). Refer to the applicable model's service information.
3. After reconnecting the 12-volt battery, turn the ignition to ON, and check if the SRS indicator comes on for about 6 seconds, then goes off. If the indicator does not come on, or comes on and stays on, follow normal troubleshooting.
4. Set the clock (for vehicles without navigation), and enter the anti-theft code for the audio and navigation system (if applicable).
5. **For airbag module replacement only** - Remove the inflator from the original airbag module. Refer to REMOVE THE INFLATOR FROM THE ORIGINAL AIRBAG MODULE.
6. **For airbag module replacement only** - Give your warranty clerk the RO that includes the replacement front passenger's airbag module serial number and replacement part number, and the two photos. For the warranty claim to be paid the **new front replacement passenger's airbag module part number and serial number** must be included in the warranty claim.

## REMOVE THE INFLATOR FROM THE ORIGINAL AIRBAG MODULE

### NOTE

If you replaced the original airbag module because of an incorrectly installed inflator, you must remove the inflator from the original airbag module, and return the inflator as part of your pallet shipment to its supplier.

1. Order a new inflator box from XPO to return the original airbag module inflator. Use the contact information below:

Primary Contact: Tel#: 1-210-250-5079

Email: SCFieldAction.14305@xpo.com

2. Remove the harness from the inflator bracket.
3. Short the red and yellow wires.

### NOTE

**Depending on the vehicle, you must cut the red or yellow wires to remove the inflator, and both sets of wires must be shorted to prevent accidental deployment.**

- 3.1. Cut the red wires about 2 inches from the inflator.

### NOTE

There may be some protective tube covering the wires that needs to be cut away to access the wires.

Cut the harness on this side.



Cut the red wires.



- 3.2. Strip away about 1 inch of the red wire insulation, then twist the wires together.

Twist the ends together.



ELECTRICAL TAPE



- 3.3. Tape the twisted ends with electrical tape.
- 3.4. Cut the yellow wires about 2 inches from the inflator.

Cut.



3.5. Strip away about 1 inch of the yellow wire insulation, then twist the wires together.

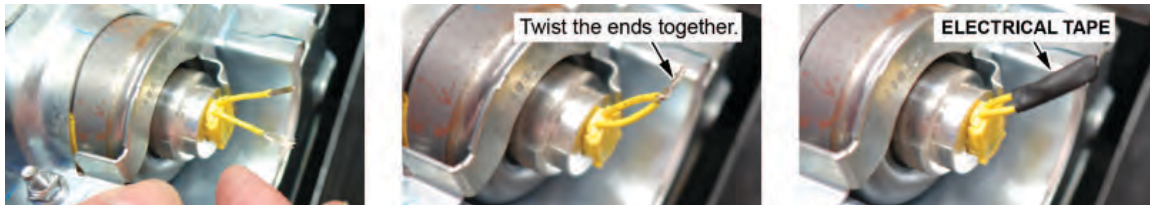

3.6. Tape the twisted ends with electrical tape.

3.7. Remove the four inflator nuts.

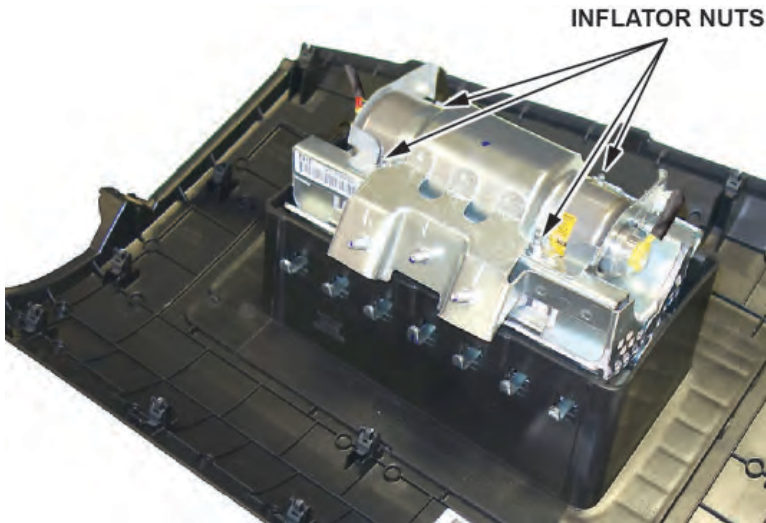

4. Remove the inflator bracket.

**NOTE**

You can only remove one of the brackets, as the other is welded to the airbag housing.



**INFLATOR BRACKET**  
Do not reuse.

5. Remove the inflator by pulling it out.



6. Put the original inflator into the new inflator box acquired from XPO. Make sure there is no other hardware in the box because if the package rattles, it will not be accepted by the courier.
7. Follow the shipping instructions outlined in PIB B15-0006 to return the undeployed inflator.
8. Place the original airbag module (without the inflator) in the airbag module box that the replacement came in. Properly fill out and attach a warranty claim tag to it. The original airbag module may be called in by AHM.

END