

September 17, 2018

10076 Version 4

## Transmission End Cover Leaks (9-Speed A/T)

Supersedes 15-039, dated September 9, 2017, to revise the information highlighted in yellow

### AFFECTED VEHICLES

Year	Model	Trim	VIN Range
2016-17	MDX	ALL with 9-speed A/T	ALL
2018	MDX	AWD	5J8YD4H..JL000001 thru 5J8YD4H..JL028339
2019	MDX	2WD	5J8YD3H..KL000008 thru 5J8YD3H..KL000552
2015-18	TLX	ALL with 9-speed A/T	ALL
2019	TLX AWD	9-speed A/T	19UUB3F..KA000002 thru 19UUB3F..KA002947
2019	TLX 2WD	9-speed A/T	19UUB2F..KA000001 thru 19UUB2F..KA003475

### REVISION SUMMARY

Under AFFECTED VEHICLES, 2018-19 MDX, and TLX were added.

### SYMPTOM

The transmission end cover leaks on vehicles with 9-speed A/T.

### POSSIBLE CAUSES

During assembly, the transmission end cover sealing gasket gets torn.

### CORRECTIVE ACTION

Replace the transmission end cover sealing gasket.

### REQUIRED MATERIALS

Part Name	Part Number	Quantity
ATF Type 3.1	08200-9017A	1

### PARTS INFORMATION

Part Name	Part Number	Quantity
End Cover Kit: (contains 11 Torx bolts, cover, seal, and plugs)	06233-5J4-000	1

**CLIENT INFORMATION:** The information in this bulletin is intended for use only by skilled technicians who have the proper tools, equipment, and training to correctly and safely maintain your vehicle. These procedures should not be attempted by "do-it-yourselfers," and you should not assume this bulletin applies to your vehicle, or that your vehicle has the condition described. To determine whether this information applies, contact an authorized Acura automobile dealer.

## WARRANTY CLAIM INFORMATION

The normal warranty applies.

### WARRANTY CLAIM INFORMATION (TLX)

Operation Number	Description	Flat Rate Time	Template ID	Failed Part Number
2321S2	Replace the transmission end cover sealing gasket (TLX) (includes ATF level check).	1.1 hrs	15-039N	20021-5L9-053

### WARRANTY CLAIM INFORMATION (MDX)

Operation Number	Description	Flat Rate Time	Template ID	Failed Part Number
2321S2	Replace the transmission end cover sealing gasket (MDX) (includes ATF level check).	1.0 hrs	15-039P	20021-5NB-043

Defect Code: 07408

Symptom Code: 05103

Skill Level: Repair Technician

## REPAIR PROCEDURE

■ Raise the vehicle on a lift.

■ *TLX Only:* Remove the undercover.

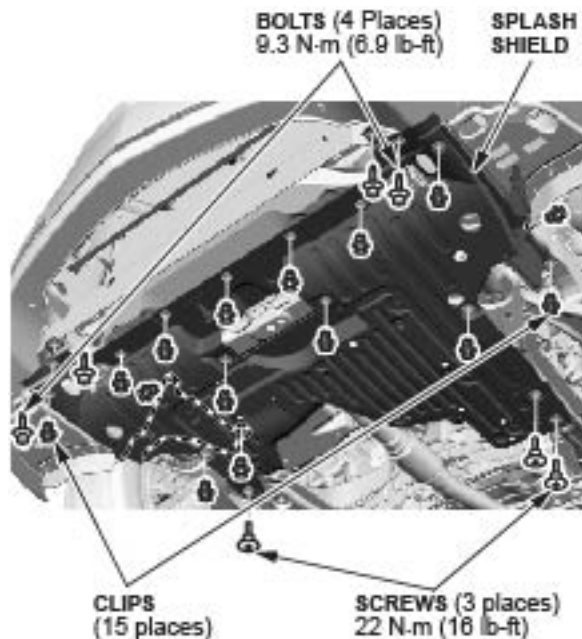

Loosen and remove the fender liner as needed to access the transmission end cover.

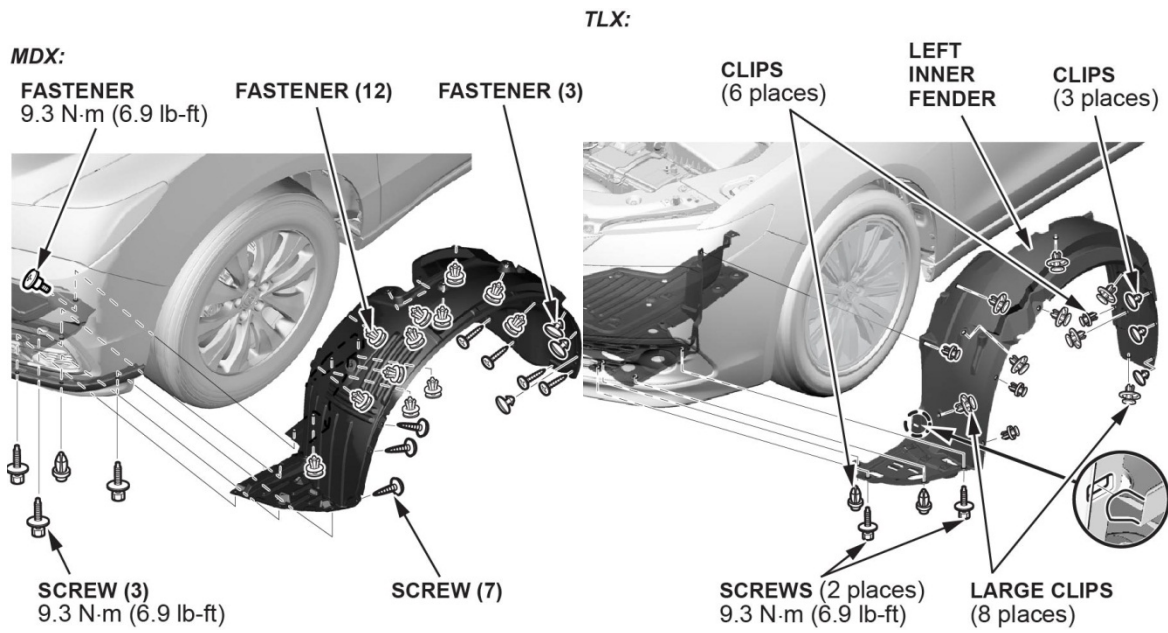

Use a strap to hold the fender liner out of the way.

**TLX Only:** Remove the resonator box and move the intake tube.



■ Remove the 11 T-30 Torx bolts from the end cover.

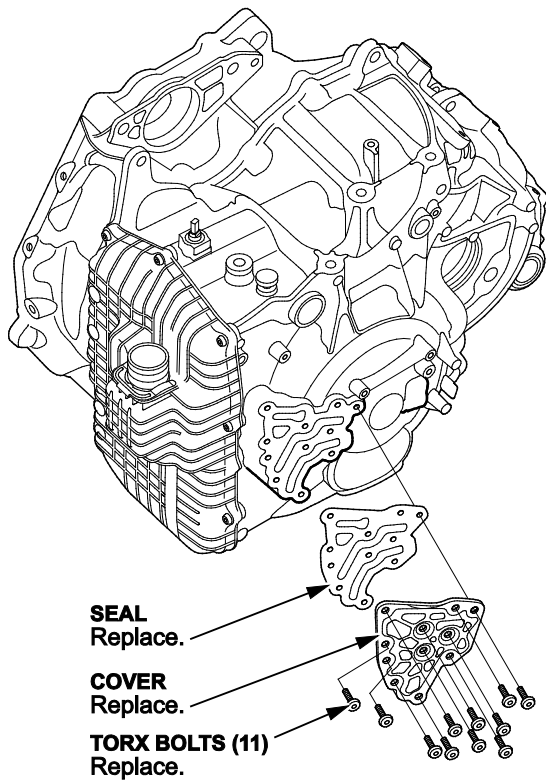

■ Replace the cover, the sealing gasket, and bolts with the new ones from the kit. Torque the bolts to **10.0 N·m (7 lb-ft)** in the sequence shown.

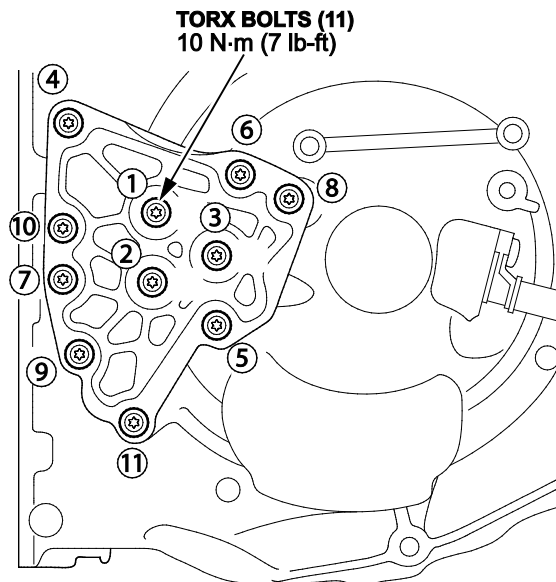

■ *TLX Only:* Reinstall the resonator box, intake tube, and undercover.

■ Reinstall the fender liner.

## ATF LEVEL CHECK

### Before You Start

- Connect the i-HDS. Go to the **A/T Data List**, and scroll down to **ATF Temperature**.
- Raise the vehicle on a lift, remove the engine undercovers (if needed), and slightly loosen the level plug.
- **Enter VSA Maintenance Mode**

**NOTE:** You **must** enter this mode to complete the ATF level check; it disables the VSA and TCS functions. Be sure to complete all of the following steps within **30 seconds**, or you'll need to start over.

- Turn the ignition to ON.
- Press and hold the brake pedal, and release the parking brake.
- Press and hold the VSA OFF switch until the VSA OFF indicator comes on. Then, press the switch again until the indicator goes out.
- Release the brake pedal, and set the parking brake.
- Press and hold the VSA OFF switch until the VSA OFF indicator comes on. Then, press the switch again until the indicator goes out.
- Press and hold the brake pedal.
- Press the VSA OFF switch. If the VSA OFF indicator comes on, press the switch again and release it. If successful, the VSA OFF indicator starts blinking and the VSA indicator comes on. You are now in VSA maintenance mode. To exit this mode, either turn the ignition switch to OFF or quickly press and release the VSA OFF switch, making sure the VSA OFF and VSA indicators go out.

### Check the ATF Level

- Start the engine, and wait for the transmission temperature to reach **90°F**.

**NOTE:** If the temperature is more than **115°F** (the vehicle may have been recently driven), shut off the engine and let the transmission cool down before continuing.
- Shift to Drive, then press the D/S button again to enter sequential mode.
- Using the paddle shifters, shift to **1st**, **2nd**, **3rd**, then **4th** gear. Then, shift back to **3rd**, **2nd**, and **1st** gear.

**IMPORTANT:** Do not shift past **4th** gear with the vehicle on the lift; you could damage the transmission.
- Apply the brakes to stop the wheels from spinning, then shift to Park.
- Raise the engine speed to **2,000 rpm** for about **5 seconds**, then release the accelerator pedal. Repeat this until the transmission temperature reaches about **100°F**, then wait for the temperature to reach **104 to 115°F**.

**NOTE:** The ideal temperature for checking the ATF level is **104°F**. If it's more than **115°F**, shut off the engine, let the transmission cool down, and start over again.

With the engine running, remove the level plug.

**IMPORTANT:** With the level plug removed, you **must** keep the engine running. If you shut it off, the ATF will pour out of the transmission.

- If a small amount of ATF trickles out of the level plug hole and keeps doing so, the level is OK. Install a new level plug, and torque it to **35 N·m (26 lb-ft)**.
- If no ATF comes out, loosely install a new level plug and lower the vehicle. Remove the fill plug, and add the appropriate amount of ATF Type 3.1 through the fill plug hole. Then, install a new fill plug, and check the ATF level again by removing the level plug. Be sure to monitor the ATF temperature while doing this. When you're done, install the level plug, then torque the level and fill plugs to **35 N·m (26 lb-ft)**.

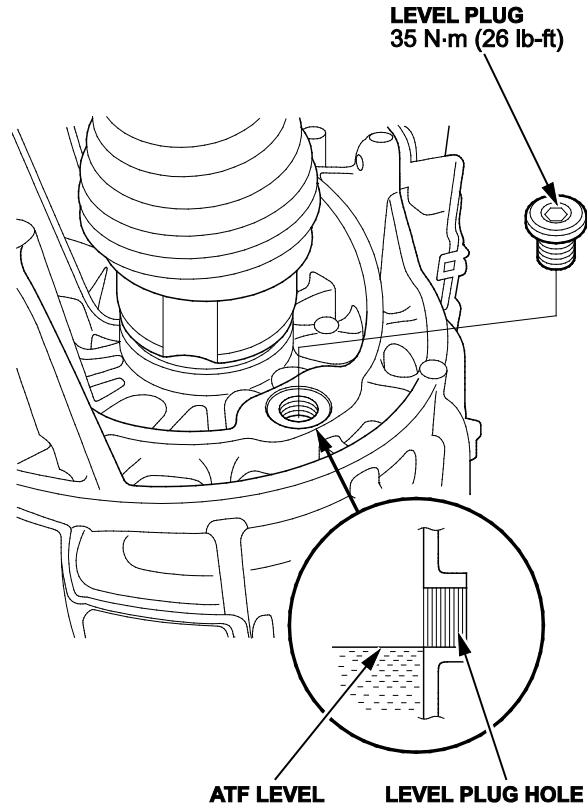

Install the engine undercovers (if removed).

Turn the engine off.

END