



Subject: SQUEAK NOISE FROM RIGHT FRONT DRIVESHAFT	Bulletin No.: 03-002/18
	Last Issued: 08/17/2018

APPLICABLE MODEL(S)/VINS

2012-2013 Mazda3 (2.0L SKYACTIV A/T only)

2014-2018 Mazda3 (A/T only)

2014-2018 Mazda6 (A/T only) with VINs lower than JM1GL*****319103 (produced before June 5, 2018)

2016-2018 CX-3 with VINs lower than JM1DK*****410711 (produced before May 25, 2018)

2013-2018 CX-5 (A/T only) with VINs lower than JM3KF*****353639 (produced before February 2, 2018)

DESCRIPTION

Some vehicles may exhibit a squeak noise from the right front driveshaft at the transaxle when driving. This concern is likely to occur when driving at speeds between 37-50 mph (60-80 km/h) with the ATF at normal operating temperature. The noise is caused by stick/slip between the oil seal at the transaxle and the dust cover of the driveshaft. To correct this issue, the thickness of the dust cover has been increased.

Customers having this concern should have their vehicle repaired using the following repair procedure.

REPAIR PROCEDURE

1. Verify concern
2. Replace the dust cover and the transfer oil seal with modified ones according to the instructions on MGSS (FRONT DRIVE SHAFT REMOVAL/INSTALLATION).

- 2012-2013 Mazda3 (FRONT DRIVE SHAFT REMOVAL/INSTALLATION)
- 2014-2018 Mazda3 (FRONT DRIVE SHAFT REMOVAL/INSTALLATION)
- 2014-2017 Mazda6 (FRONT DRIVE SHAFT REMOVAL/INSTALLATION)
- 2018 Mazda6 (FRONT DRIVE SHAFT REMOVAL/INSTALLATION)
- 2016-2018 CX-3 (FRONT DRIVE SHAFT REMOVAL/INSTALLATION)
- 2013-2016 CX-5 (FRONT DRIVE SHAFT REMOVAL/INSTALLATION)
- 2017-2018 CX-5 (FRONT DRIVE SHAFT REMOVAL/INSTALLATION)

CONSUMER NOTICE: The information and instructions in this bulletin are intended for use by skilled technicians. Mazda technicians utilize the proper tools/equipment and take training to correctly and safely maintain Mazda vehicles. These instructions should not be performed by "do-it-yourselfers." Customers should not assume this bulletin applies to their vehicle or that their vehicle will develop the described concern. To determine if the information applies, customers should contact their nearest authorized Mazda dealership. Mazda North American Operations reserves the right to alter the specifications and contents of this bulletin without obligation or advance notice. All rights reserved. No part of this bulletin may be reproduced in any form or by any means, electronic or mechanical---including photocopying and recording and the use of any kind of information storage and retrieval system ---without permission in writing.

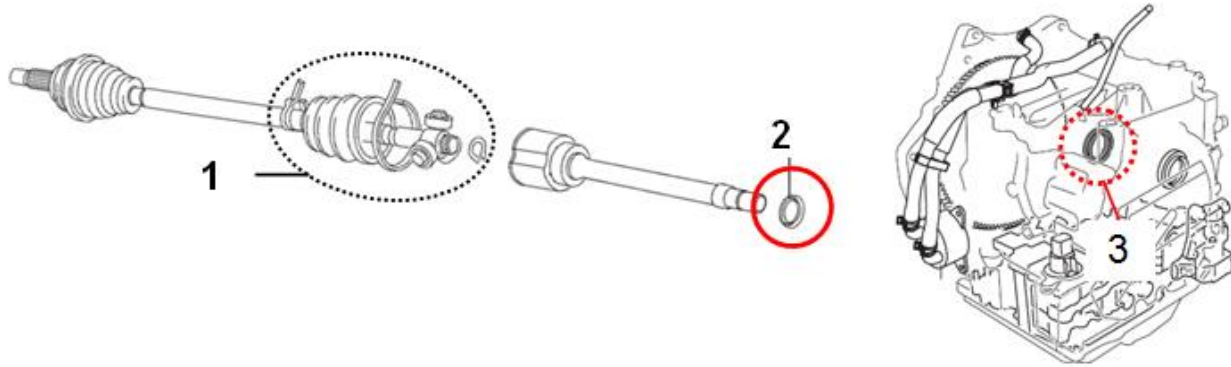

1	Inner joint boot set
2	Dust cover
3	Oil Seal

3. Verify repair.

PARTS INFORMATION

Parts Number	Description	Qty.	Notes
FTH1-25-722	Dust cover	1	
FZ01-27-238	Seal, Oil	1	
D651-33-042A	Locknut	1	[R]
T060-26-169A	Pin, Snap	1	[R]
FTC6-22-540	Boot Set Inner Joint	1	[R] CX-3
FTC3-22-540	Boot Set Inner Joint	1	[R] Mazda3 with 2.0L
FTU8-22-540	Boot Set Inner Joint	1	[R] Mazda3 with 2.0L
FTC4-22-540	Boot Set Inner Joint	1	[R] Mazda3 with 2.5L
FTC8-22-540	Boot Set Inner Joint	1	[R] Mazda3, Mazda6 and CX-5 with 2.0L or 2.5L
GG62-22-540	Boot Set Inner Joint	1	[R] Mazda6 and CX-5 with 2.0L or 2.5L
0000-FZ-113E-01	ATF-FZ	As needed	Maximum 8.2 quarts (7.8 L)

NOTE: Confirm the part number in the GEPC for the subject VIN and place an order for the corresponding service part.

CONSUMER NOTICE: The information and instructions in this bulletin are intended for use by skilled technicians. Mazda technicians utilize the proper tools/equipment and take training to correctly and safely maintain Mazda vehicles. These instructions should not be performed by "do-it-yourselfers." Customers should not assume this bulletin applies to their vehicle or that their vehicle will develop the described concern. To determine if the information applies, customers should contact their nearest authorized Mazda dealership. Mazda North American Operations reserves the right to alter the specifications and contents of this bulletin without obligation or advance notice. All rights reserved. No part of this bulletin may be reproduced in any form or by any means, electronic or mechanical---including photocopying and recording and the use of any kind of information storage and retrieval system ---without permission in writing.

WARRANTY INFORMATION

NOTE:

- This warranty information applies only to verified customer complaints on vehicles eligible for warranty repair.
- This repair will be covered under Mazda's Powertrain Limited Warranty.
- Additional diagnostic time cannot be claimed for this repair.

Warranty Type	A
Symptom Code	82
Damage Code	97
Part Number Main Cause	FTH1-25-722
Quantity	1
Operation Number / Labor Hours:	XXP78DRX / 1.5 hrs.

NOTE: Claim ATF as related part (maximum 8.2 quarts (7.8 L)).

CONSUMER NOTICE: The information and instructions in this bulletin are intended for use by skilled technicians. Mazda technicians utilize the proper tools/equipment and take training to correctly and safely maintain Mazda vehicles. These instructions should not be performed by "do-it-yourselfers." Customers should not assume this bulletin applies to their vehicle or that their vehicle will develop the described concern. To determine if the information applies, customers should contact their nearest authorized Mazda dealership. Mazda North American Operations reserves the right to alter the specifications and contents of this bulletin without obligation or advance notice. All rights reserved. No part of this bulletin may be reproduced in any form or by any means, electronic or mechanical---including photocopying and recording and the use of any kind of information storage and retrieval system ---without permission in writing.