

Technical Service Bulletin

Mazda North American Operations
Irvine, CA 92618-2922



Subject: SPECIAL SERVICE TOOL LOANER ANNOUNCEMENT - AUGUST 2015	Bulletin No.: 00-004/18
	Last Issued: 08/10/2018

BULLETIN NOTES

This bulletin supersedes the previously issued bulletin(s) listed below. The changes are noted in Red.

Previous TSBs:	Issued Dates:
00-003/17	12/22/17
00-005/16	08/26/16
00-001/15	08/06/15

APPLICABLE MODEL(S)/VINS

2016-2019 CX-3

2016-2019 MX-5

DESCRIPTION

In support of the new Mazda MX-5 and CX-3, Mazda will make available for loan on a “as-needed” basis, a Special Service Tool (SST) to allow for the radar aiming of the blind spot monitoring (BSM) system. The (BSM) radar aiming is performed whenever the (BSM) control module, the (BSM) bracket or the rear bumper is replaced. The tool is available for loan by contacting DAG at (877)727-6626, option 2.

PRICING

Part Number	Description	Pricing
49G0-67-0A0L	Doppler Radar Simulator Tool (Loaner)	\$3500.00 (Dealer will be reimbursed when the tool is returned)

CONSUMER NOTICE: The information and instructions in this bulletin are intended for use by skilled technicians. Mazda technicians utilize the proper tools/equipment and take training to correctly and safely maintain Mazda vehicles. These instructions should not be performed by “do-it-yourselfers.” Customers should not assume this bulletin applies to their vehicle or that their vehicle will develop the described concern. To determine if the information applies, customers should contact their nearest authorized Mazda dealership. Mazda North American Operations reserves the right to alter the specifications and contents of this bulletin without obligation or advance notice. All rights reserved. No part of this bulletin may be reproduced in any form or by any means, electronic or mechanical---including photocopying and recording and the use of any kind of information storage and retrieval system ---without permission in writing.

SHIPPING INFORMATION

IMPORTANT:

- The tool will be delivered with your Dedicated Parts Delivery Service (DDS).
- Ensure all related repairs are completed prior to the tool's arrival at the dealer.
- Dealer is responsible for packaging and returning the tool in the same condition as it was delivered.

SPECIAL SERVICE TOOL (SST) AND USAGE

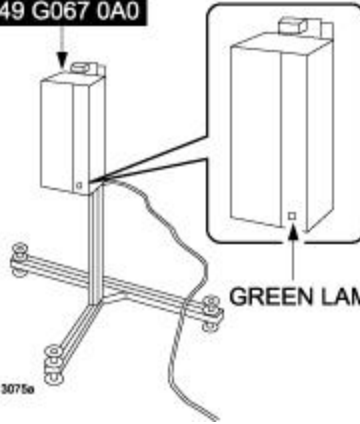
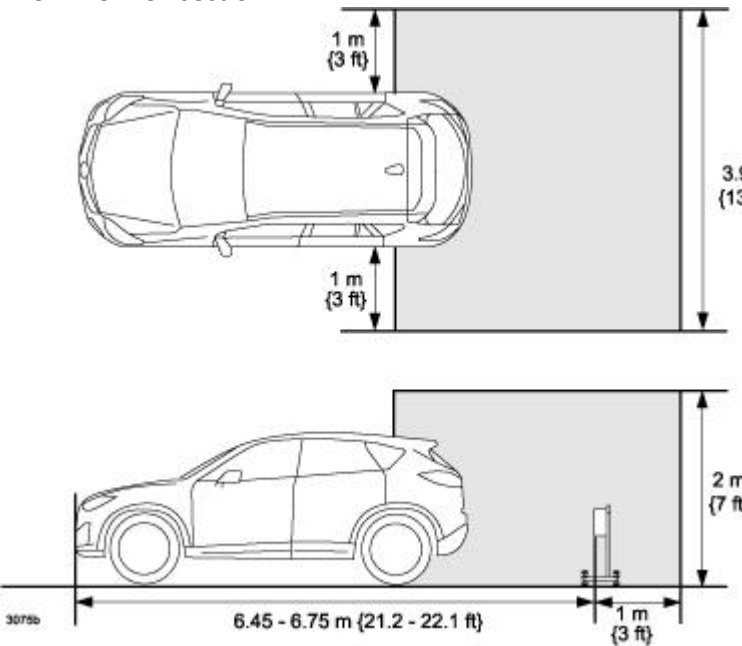
<p>PART NUMBER / NAME: 49G0-67-0A0L Doppler Radar Simulator Tool (Loaner)</p> <p>APPLICABLE MODELS: 2016-2019 CX-3 and MX-5</p> <p>USAGE: For radar aiming of the Blind Spot Monitoring System (BSM).</p>	<p>OVERVIEW 49 G067 0A0</p> 	<p>USAGE Aiming procedure in the Workshop Manual - i-ACTIVESENSE section.</p> 
--	--	--

CONSUMER NOTICE: The information and instructions in this bulletin are intended for use by skilled technicians. Mazda technicians utilize the proper tools/equipment and take training to correctly and safely maintain Mazda vehicles. These instructions should not be performed by "do-it-yourselfers." Customers should not assume this bulletin applies to their vehicle or that their vehicle will develop the described concern. To determine if the information applies, customers should contact their nearest authorized Mazda dealership. Mazda North American Operations reserves the right to alter the specifications and contents of this bulletin without obligation or advance notice. All rights reserved. No part of this bulletin may be reproduced in any form or by any means, electronic or mechanical---including photocopying and recording and the use of any kind of information storage and retrieval system ---without permission in writing.