



MAINTENANCE INFORMATION

MI16-17G

DATE :	FEBRUARY 2016	SECTION :	06 - Electrical
SUBJECT :	BOSCH HD10 ALTERNATOR REMOVAL AND INSTALLATION		

REVISION G: THIS MAINTENANCE INFORMATION SUPERSEDES ALL PREVIOUS VERSIONS.
 Released : July 2018
 M8 nut was part #5001787, cancelled and changed. Use M8 nut part #5001983.

DESCRIPTION

Use this procedure for the removal and installation of the **Bosch HD10 (120A or 150A)** alternator.

CONTENT

REQUIRED TOOLS 2



PART 1 – COLD SIDE TWIN BOSCH ALTERNATOR REMOVAL / INSTALLATION 3

PART 2 – PULLEY REMOVAL / INSTALLATION17

PART 3 – ASSEMBLY INSTRUCTIONS FOR ELECTROMAGNETIC CLUTCH – LINNIG LA1620

PART 4 –HOT SIDE SINGLE BOSCH ALTERNATOR REMOVAL AND INSTALLATION21

REQUIRED TOOLS

METRIC OPEN END WRENCH SET 	RATCHET AND SOCKET SET – METRIC 
HEX BIT SOCKET SET – METRIC 	TORQUE WRENCH 
SOFT FACED HAMMER 	1 5/8 OPEN END WRENCH 
BELT TENSION GAUGE 	1/2 SQUARE DRIVE BREAKER BAR 
voltmeter / MULTIMETER 	CUTTING PLIERS 

See “SPECIAL TOOLS REQUIRED TO TIGHTEN THE ALTERNATOR PULLEY MOUNTING NUT” in PART 2

PART 1 – COLD SIDE TWIN BOSCH ALTERNATOR REMOVAL / INSTALLATION



DANGER

Park vehicle safely, apply parking brake, stop engine. Prior to working on the vehicle, **set the ignition switch to the OFF position, the battery master switch (master cut-out) to the OFF position and trip the main circuit breakers equipped with a trip button.**

RISK OF ELECTRICAL SHOCK

- The alternator is connected to the batteries through master relay R1. If the ignition switch is in the OFF position and the battery master switch (master cut-out) is set to the OFF position, there should not be electrical power to the alternator terminals. However, a faulty master relay R1 could eventually leave the battery power circuit closed, thus electrical power would be present at the alternator terminals.
- Using a multimeter, probe the alternator **B1+** terminal and the ground terminal. Make sure that the voltage reading is 0 volt prior disconnecting the alternator cables.

GAINING ACCESS TO THE ALTERNATORS

1. Loosen bolt **A**.
2. Unscrew and remove bolt **B**.
3. Remove the drive belt mechanical tensioner assembly (**FIGURE 2**).
4. Remove the A/C compressor drive belts (2 side-by-side belts).

Note: Keep hardware for reuse

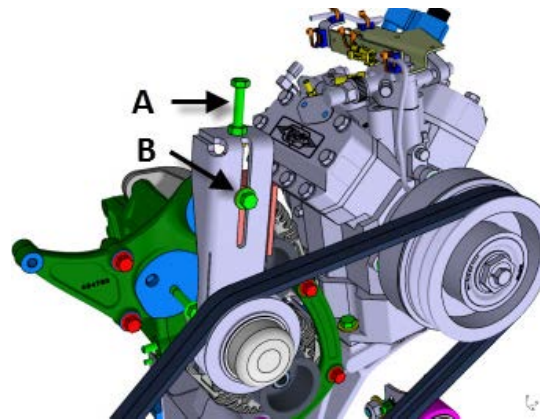

FIGURE 1

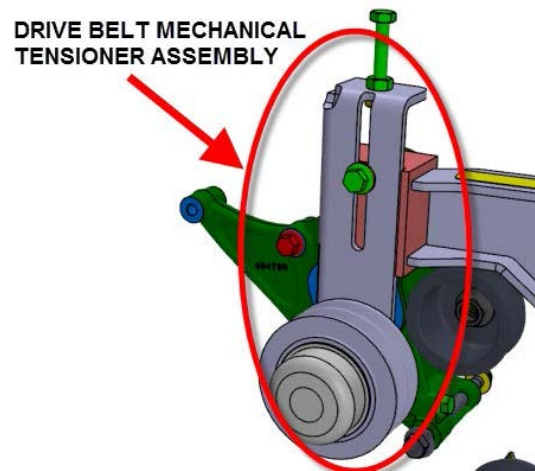

FIGURE 2

ALTERNATOR REMOVAL

5. Unscrew and remove bolt **C** (FIGURE 3).

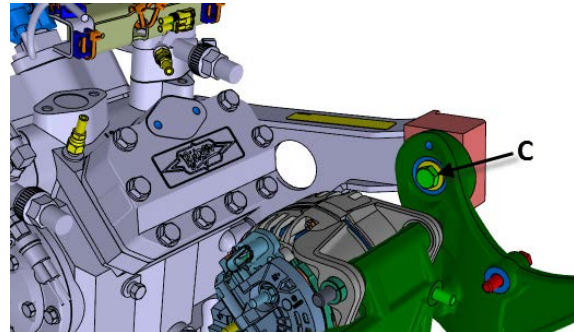
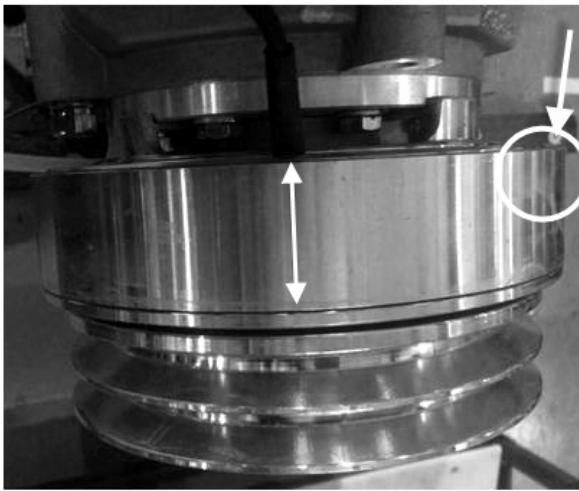
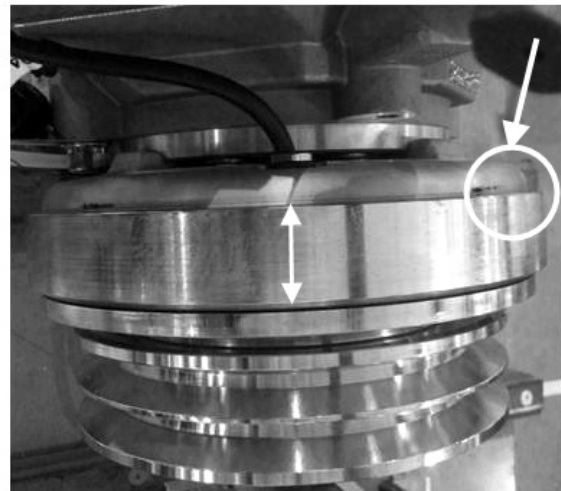

FIGURE 3

6. At this point, identify the type of clutch installed on your vehicle.



LANG TYPE: SHARP EDGE COIL



LINNIG TYPE: ROUND EDGE COIL

FIGURE 4

7. As an alternate way to confirm **LANG** type clutch, locate “LANG” engraving on the hub center

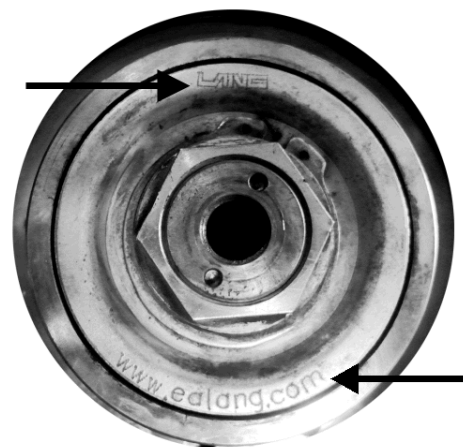

FIGURE 5

8. If a **LINNIG** type clutch is installed, refer to "PART 3 - ASSEMBLY INSTRUCTIONS FOR ELECTROMAGNETIC CLUTCH - LINNIG LA16". Remove the Linnig clutch.
9. Remove the LANG electromagnetic clutch assembly (FIGURE 6).

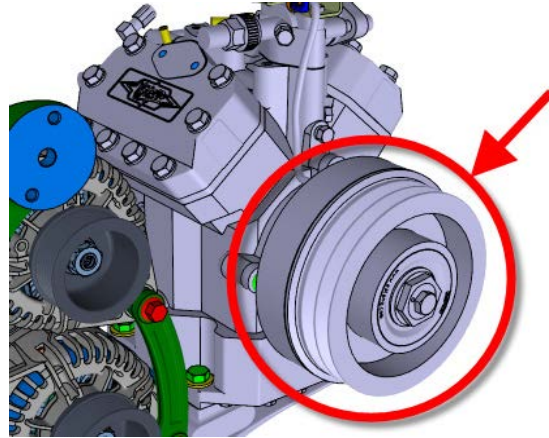
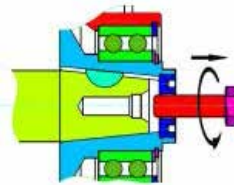

FIGURE 6

10. Hold the rotor with the 1 5/8 wrench. Loosen and remove the M12 rotor mounting screw with a 30mm socket.



REMOVING THE M12 SCREW

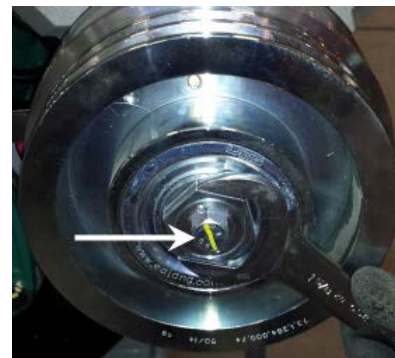
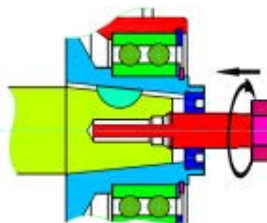

FIGURE 7

For the next step, use rotor extractor tool #680888.

11. Screw the extractor tool into the straining washer only until the rotor pops off the tapered shaft. Then work the rotor off the shaft by hand with help from soft faced mallet as needed.



PULL OFF THE ROTOR WITH TOOL #680888 (shown)

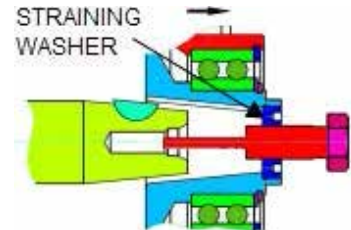

TAKE OFF THE ROTOR

FIGURE 8

12. Loosen the fastening screws (4x) of the coil and pull the coil off the retainer.

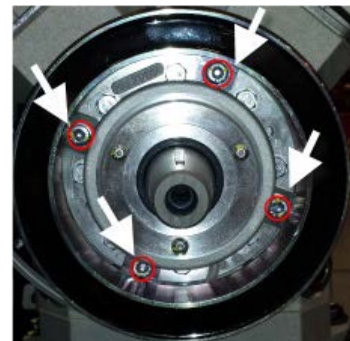

FIGURE 9

13. Unscrew and remove two socket cap screws **E** (**FIGURE 10**).
14. Put the reinforcement bracket aside.

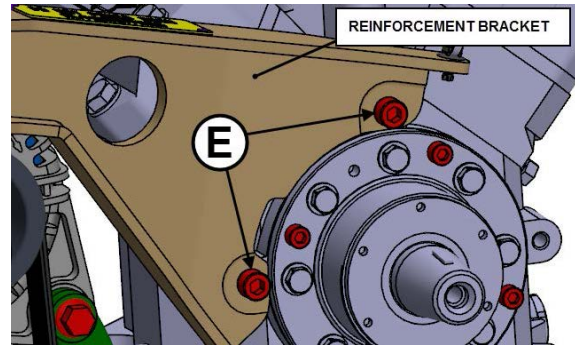

FIGURE 10

15. Remove the alternator drive belt. To do so, rotate the automatic belt tensioner using a $\frac{1}{2}$ square drive breaker bar.
16. Remove the alternator belt tensioner bracket assembly. To do so, remove the three bolts identified with arrows on **FIGURE 11**.
17. Put the alternator drive belt aside.

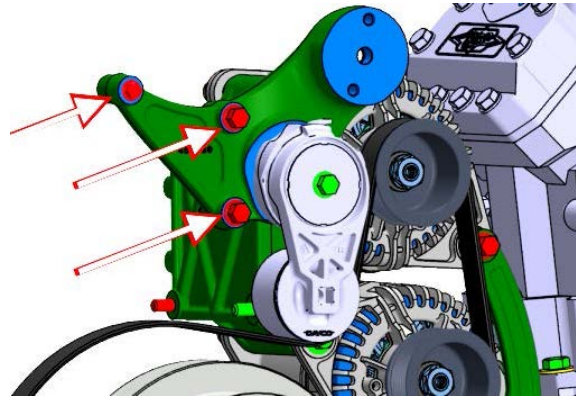

FIGURE 11

18. Disconnect the alternator cables. Properly clean cable ring terminals as applicable using a brass wire cup brush, a Scotch-Brite pad or an emery cloth.

Keep hardware for reuse.

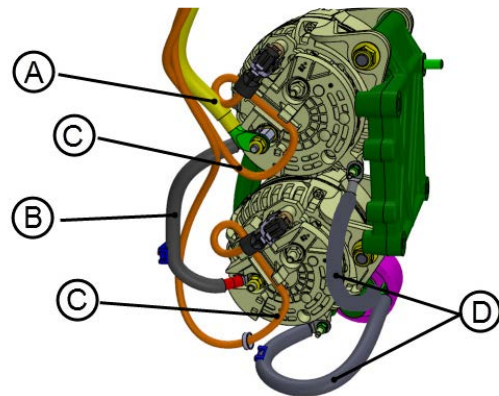

FIGURE 12

- A: (+) POWER CABLE**
B: (+) JUMPER CABLE
C: ALTERNATOR HARNESS
D: GROUND CABLE

19. Remove the existing alternators. To do so, unscrew the four (4) mounting bolts identified on **FIGURE 13**.

Keep hardware for reuse.

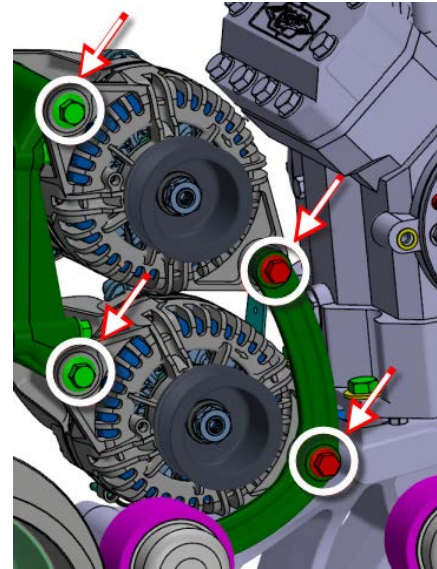

FIGURE 13

ALTERNATOR INSTALLATION

20. Apply anti-seize compound (Prevost p/n: 680335) inside the alternator mounting ears (FIGURE 14) and inside the sleeves on the alternator support (FIGURE 15).

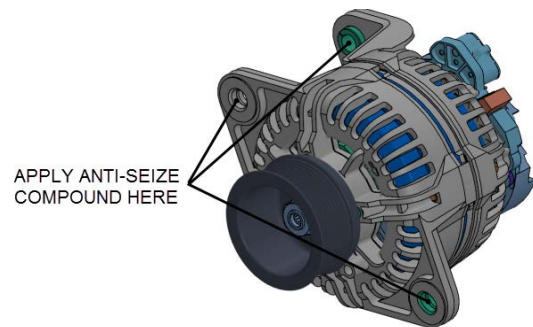

FIGURE 14

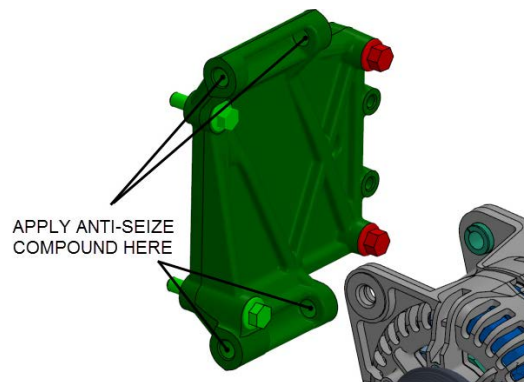

FIGURE 15

21. Install the alternators. Fix lower and upper alternators loosely to alternator supports using bolts **C**. Also, mount arched support loosely onto alternators using bolts **B** (FIGURE 16).

Use Loctite 243 Blue on threads.

NOTE: Reuse existing bolts unless they are not in good condition (damaged, pitted, eroded).

For reference:

C= NUT M12 p/n 5001761 (2X)

C= BOLT M12x160 p/n 5001853 (2X)

B= NUT M10 p/n 5001930 (2X)

B= BOLT M10x45 p/n 5001800 (2X)

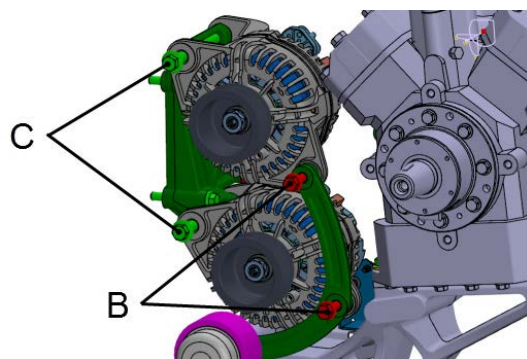

FIGURE 16

22. In order to assure proper installation, it is important to tighten the alternator mounting bolts in proper sequence (FIGURE 17).

*Tighten bolt **B** first, then finish with bolt **C***

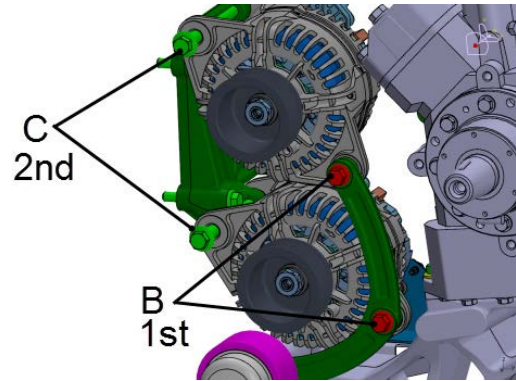

FIGURE 17

B: *torque 48 lbf-ft*

C: *torque 82 lbf-ft*

23. Connect jumper cable **B** to **B1+** stud terminal of the upper alternator and the lower alternator using hardware shown on FIGURE 18.

- Install jumper cable **B** onto **B1+** stud terminal on upper alternator.
- Place one flat washer **D** against the jumper cable lug.
- Screw and tighten the adapter stud **C**.
- Fit jumper cable **B** onto **B1+** stud terminal on lower alternator.
- Place one flat washer **D** against the jumper cable **B** lug and screw nut **E**.

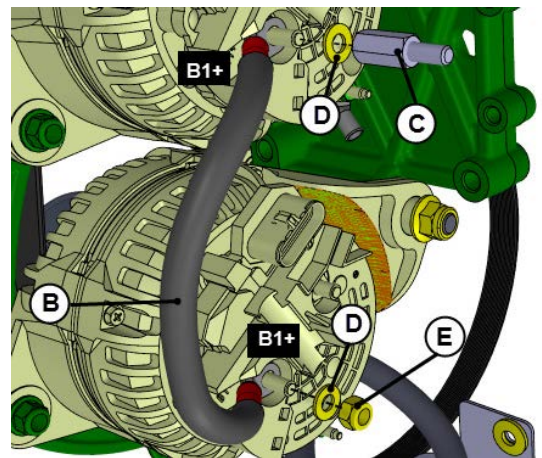

FIGURE 18

B : JUMPER CABLE p/n 067835

C : STUD ADAPTER p/n 060297 *torque: 11 lbf-ft*

D: FLAT WASHER p/n 5001341

E: NUT M8 p/n 5001983 *torque: 11 lbf-ft*

24. Reinstall the (+) power cable **A**. To do so, connect power cable **A** to the upper alternator **B1+** stud terminal. Refer to FIGURE 19.

- Fit the (+) power cable lug onto adaptor stud, place one flat washer **D** against the power cable terminal and screw nut **E**.

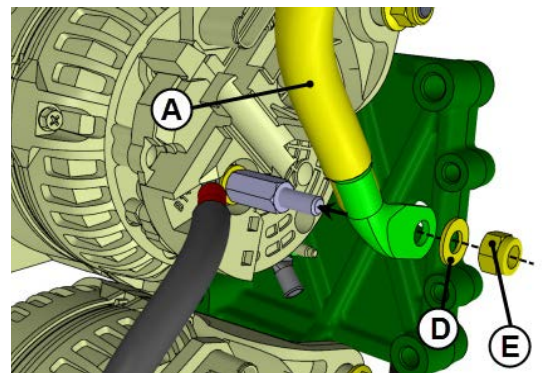

FIGURE 19

A: (+) POWER CABLE

D: FLAT WASHER P/N 5001341

E: NUT M8 P/N 5001983 *torque: 11 lbf-ft*

25. Fit the ground cables onto their respective alternator ground studs. For each alternator, place one flat washer **F** against the ground cable lug and screw nut **G**.

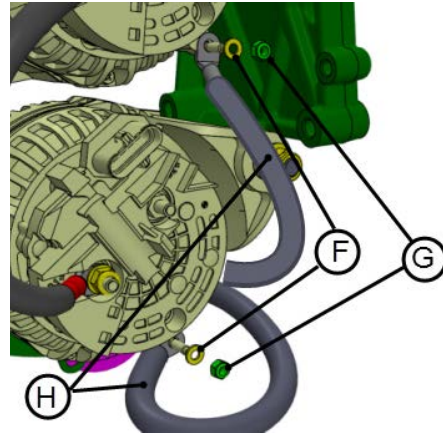

FIGURE 20

F : FLAT WASHER P/N 502573

G : NUT M6 P/N 5001182 *torque: 6 lbf-ft*

H : GROUND CABLES

26. On the upper alternator, plug alternator harness onto alternator connector and secure using nylon cable ties P/N 504637 positioned as shown by red arrows on **FIGURE 21**.

NOTE: one nylon tie is used to block the connector locking mechanism in order to prevent unwanted unlocking and disconnection.

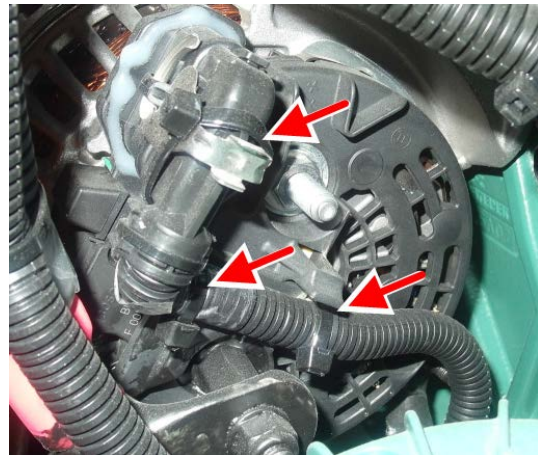

FIGURE 21

27. On the lower alternator, plug alternator harness onto alternator connector and secure using nylon cable ties P/N 504637 positioned as shown by red arrows on **FIGURE 22**.

NOTE: one nylon tie is used to block the connector locking mechanism in order to prevent unwanted unlocking and disconnection

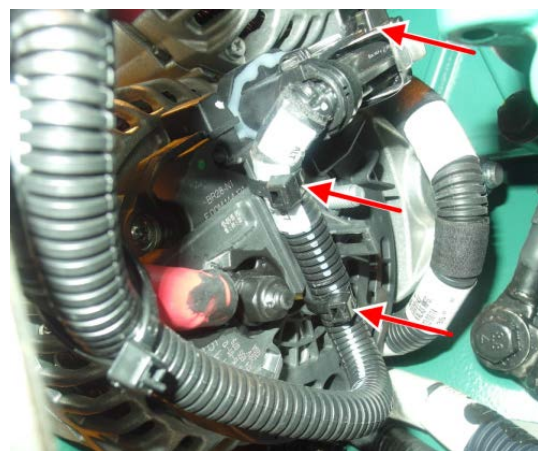

FIGURE 22

28. Apply anti-corrosion compound or **Color Guard Rubber Coating** (Prevost p/n: 684013) on alternator terminals, cable lugs and nuts.

29. Mount the alternator belt tensioner bracket assembly loosely using previously removed bolts I & J (FIGURE 23).

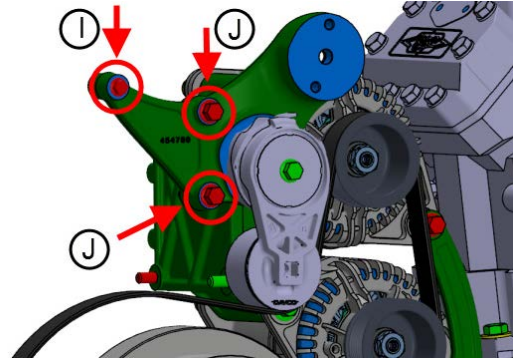

FIGURE 23

I: SCREW CAP HEXF M8-1.25X50 G10.9 p/n 500796 qty.1

J: SCREW CAP HEXF M10-1.25X55 G10.9 p/n 5001801 qty.2

30. Install the reinforcement bracket. Use two previously removed cap screws **E** and flat washers. DO NOT apply final torque at this moment.

Note: Use blue Loctite 243 on threads.

Note: Once thread locker is applied, do not wait too long before applying final torque. Final tightening will be done in the next following steps.

Cap screw E according to clutch type

Lang clutch screw E p/n 5001616

Torque **40 lbf-ft (54 N-m)**



LINNIG clutch screw E p/n 502949

Torque **32 lbf-ft (43 N-m)**

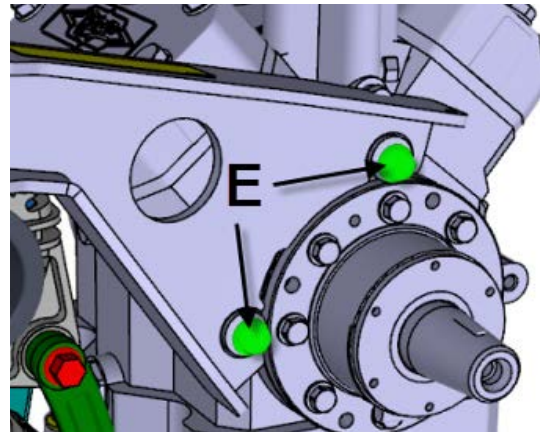
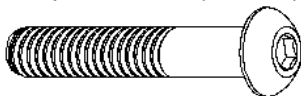

FIGURE 24

31. Continue with the installation of the reinforcement bracket as shown using previously removed hardware (bolt **C** finger tightened and flat washer). DO NOT apply final torque at this moment.

Note: Use Blue Loctite 243 on threads.

Note: Once thread locker is applied, do not wait too long before applying final torque.

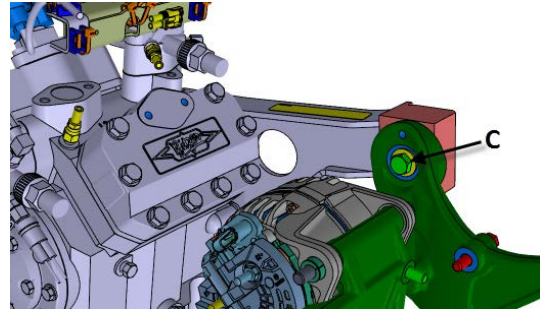

FIGURE 25

32. If bolts **C** & **E** (see two previous steps) are difficult to align in the hole, the compressor may be moved. Loosen the compressor mounting bolts (4x) at the base (see FIGURE 26)

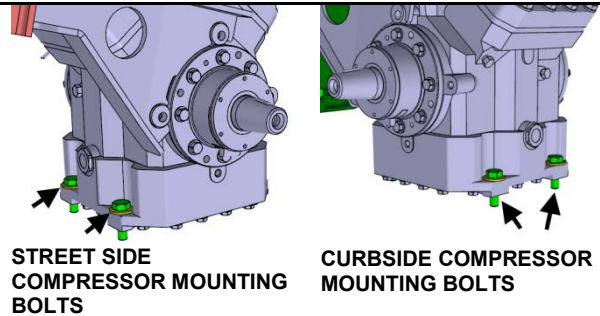

FIGURE 26

33. Snug bolts **C** & **E** (FIGURE 24 & FIGURE 25).
 34. Snug compressor mounting bolts at the base.
 35. Snug bolts **I** & **J** indicated with arrows on FIGURE 27.

Note: Use blue Loctite 243 on threads.

36. Tighten the compressor mounting bolts to **74 lbf-ft.** (100 N-m).

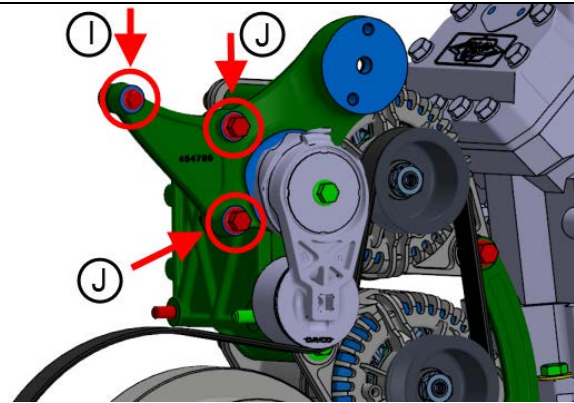

FIGURE 27

37. Tighten the three bolts shown on FIGURE 28 to prescribed torque.

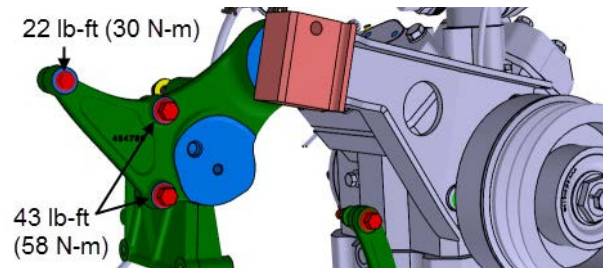
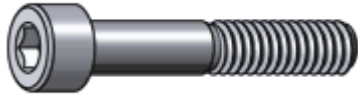

FIGURE 28

38. Tighten bolts **C** and bolt **E** (refer to FIGURE 29).

Lang clutch: E= 40 lbf-ft (54 N-m)



Linnig clutch: E= 32 lbf-ft (43 N-m)

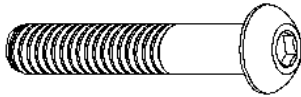

C= 74 lbf-ft (100 N-m)

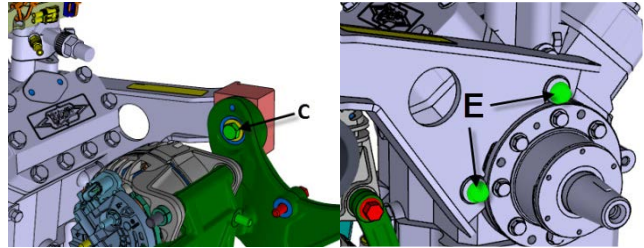

FIGURE 29

39. Reinstall the alternator belt. To do so, rotate the automatic tensioner using a ½ square drive breaker bar and install the belt as shown on FIGURE 30.

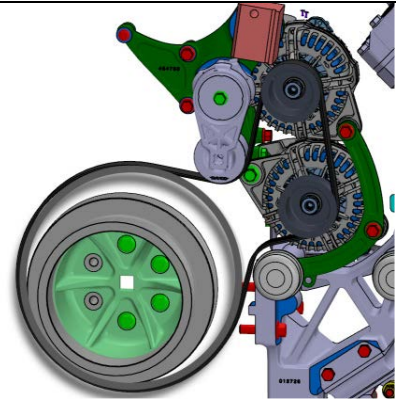

FIGURE 30

40. Reinstall tensioner, bolt and washer **B** and bolt and nut **A**. Do not tighten these bolts at this moment as the belt tension adjustment will be done later in this procedure.

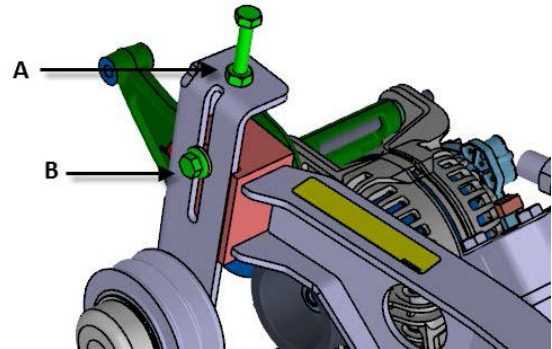

FIGURE 31

-
41. Install the electromagnetic clutch coil (for Linnig clutch, refer to PART 3). Position cable lead near the 2 o'clock position.



FIGURE 32

-
42. Slip the coil on the retainer on the compressor flange. Fasten the coil with 4 cap screws #5001775 to the compressor.

Use blue Loctite 243.

Caution: *parts should be clean and free from debris. Pay attention to the precise seat of coil. The coil should sit flush with the face of the compressor.*

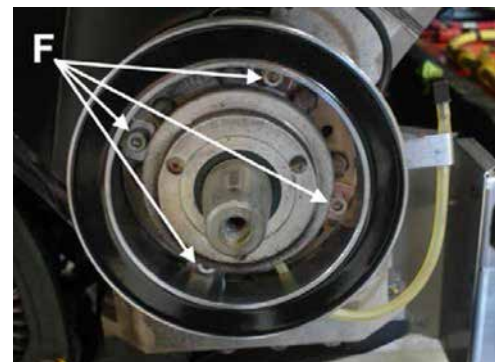

FIGURE 33

F: Coil mounting cap screws torque: 22 lbf-ft

43. Mount the rotor on the shaft end.

The flange and the shaft end of the compressor must be clean and free from dirt.

The flange and the shaft end of the compressor must be free from dirt. Apply high temperature approved assembly grease on the shaft end for easy dismounting of the clutch. Lang recommends the use of Molykote G-rapid-plus or Molykote P 40.



FIGURE 34

44. Carefully mount the rotor on the shaft end by hand.

Never use a hammer for pressing the rotor on.

Align the key on the compressor shaft with the keyway on the pulley bore. To avoid damaging the bore of the rotor, feel the engagement of the key in the keyway and slip the rotor on the shaft end of the compressor till reaching the stop (FIGURE 32).

The Woodruff key on the shaft end and the groove in the location hole of the rotor must be flush.

45. Fasten the rotor to the shaft end using the M12 screw and by holding-up with a wrench on the rotor.
46. Turn rotor by hand and pay attention to the free run and the generation of noises. In case of grinding or similar noises, dismount the clutch and check installation.

USE BLUE LOCTITE 243 ON THREADS

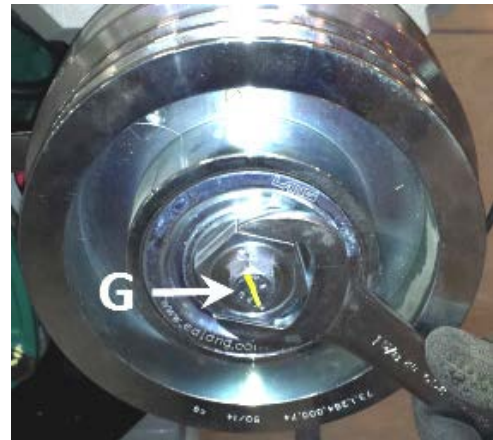

FIGURE 35

G: ROTOR MOUNTING SCREW *torque 60 LBF-FT (81 N-M)*

47. Reinstall A/C compressor drive belts.

A belt strand tension gauge is needed. Belt tension should be within the following range:

- 90-100 lbs new belts (mean of 2 belt values)
- 75-85 lbs used belts (mean of 2 belt values)

Single 5VX810 belt (FIGURE 37)

- 150-160 lbs new belt
- 120-130 lbs used belt

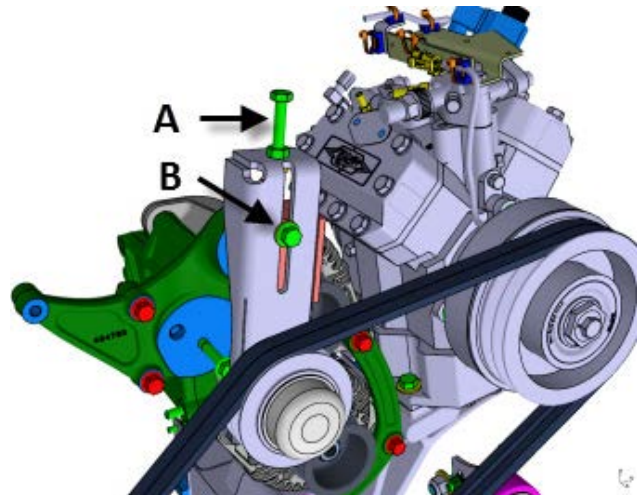

FIGURE 36

48. Apply blue Loctite 243 on bolt **B** threads and then hand-tighten bolt **B**. Adjust belt tension using bolt **A**. Use the jam nut at the base of bolt **A** to keep proper tension adjustment.

Note: Once thread locker is applied, do not wait too long before applying final torque.

When proper tension is achieved, tighten bolt **B** to **43 lbf-ft.** (58 N-m).

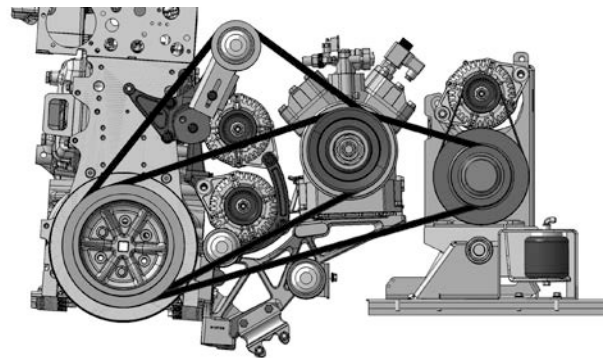



FIGURE 37

FUNCTIONAL TEST

1. Reset main circuit breakers if applicable. Set the battery master switch (master cut-out) to the ON position and start the engine. Make sure that the charging system is working normally.

On the instruments cluster, the alternator telltale  illuminates if the alternators are not charging.

PART 2 – PULLEY REMOVAL / INSTALLATION

SPECIAL TOOLS REQUIRED TO TIGHTEN THE ALTERNATOR PULLEY MOUNTING NUT



METRIC 10mm 12-POINTS SPLINE DRIVE LONG (CARLYLE SLTS3810M AVAILABLE FROM NAPA)



OFFSET 7/8 WRENCH (CYLINDER HEAD WRENCH), SNAP-ON PART NUMBER M4201



7/8 SOCKET (PART NUMBER WA28-28A)

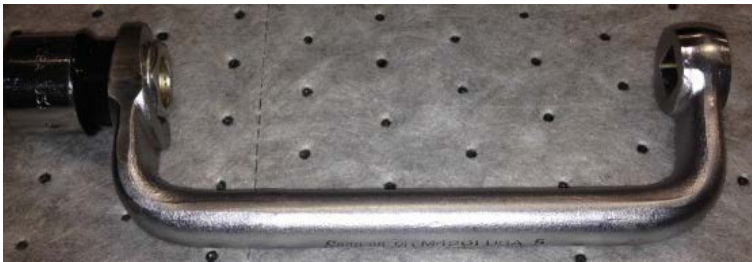

OFFSET 7/8 WRENCH FITTED WITH 7/8 SOCKET AND 10mm 12-POINTS SPLINE DRIVE



USING THE CYLINDER HEAD WRENCH WITH A RATCHET AND A FLEX SOCKET WRENCH



PULLEY REMOVAL / INSTALLATION

ALTERNATOR PULLEY MOUNTING NUT

THE ALTERNATOR MAY BE PROVIDED WITH THIS TYPE OF NUT AND WASHER - DO NOT USE



REUSE EXISTING FLANGE NUT OR USE THE NUT PROVIDED WITH THE ALTERNATOR IF IT IS A FLANGE NUT LIKE THIS ONE (#21429955 M16 x 1.5)

FIGURE 38

1. Unscrew the alternator pulley mounting nut (FIGURE 39).
2. Remove the alternator pulley (2 pulleys).

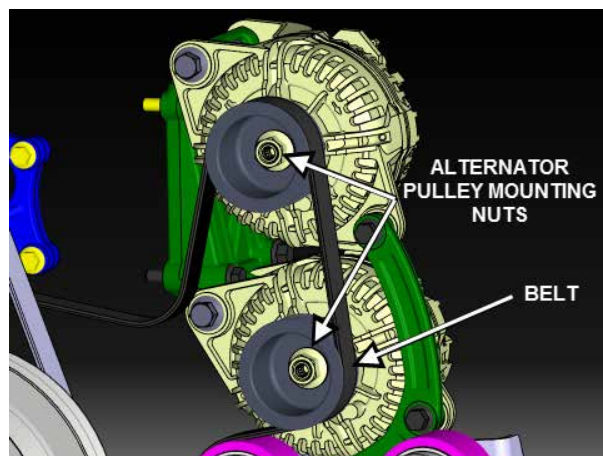

FIGURE 39

SPECIAL CASE ON 150A ALTERNATOR

One (1) flat washer #500449 **is required** between the pulley and the flange nut



3. Mount pulley onto alternators. Use Loctite 243 blue on threads. Tighten pulley mounting nut to **75 lbf-ft** using special tools and a M10 12-points spline drive mounted on a torque wrench.

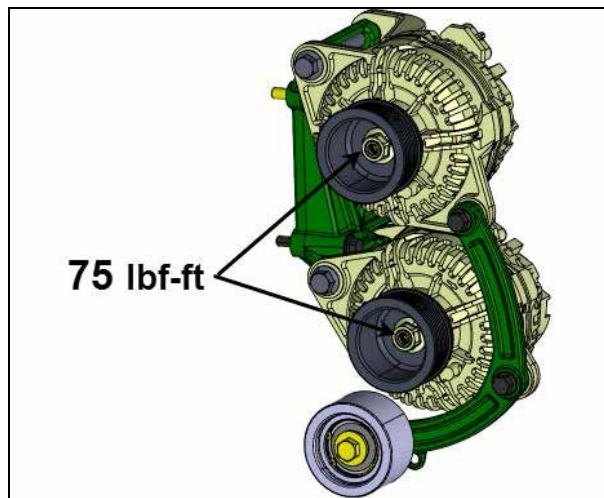

FIGURE 40

PART 3 – ASSEMBLY INSTRUCTIONS FOR ELECTROMAGNETIC CLUTCH – LINNIG LA16

Assembly instruction:

1. Attach coil according to instruction manual of the compressor manufacturer. Connect cable in a way that avoids contact with hot components (only if coil contains a cable). $t_{max} = 105^{\circ}\text{C}$
2. Remove circlip and holding-down bolt from clutch-assembly. Slide clutch-assembly onto compressor shaft. Look through the center-hole for a correct position of the compressor shaft key in the rotor-keyway. Rotor should turn freely without touching the coil. Consider the control mark! Insert and tighten holding-down bolt M12 (tightening torque $M_a = 85\text{ Nm}$, $M_a = 63\text{ lbs.ft}$). Hold down the rotor with an open-ended spanner or ring spanner WAF41. Insert circlip.
3. Slide pulley over the stud screws (1) and bolt on with nuts M8 DIN 934-8 (2) (only for LA16.3; for other LA16 is pulley integrated part of the clutch).
4. Connect cable respectively connector. The connection is independent of polarity. Allowed operating voltage 21–32 VDC.

Disassembly instruction:

For disassembly grease circlip (do not remove circlip) and turn the holding-down bolt left to loosen. Hold down the rotor with an open-ended spanner or ring spanner WAF41. In this way the clutch will be disconnected from the cone-shaft.

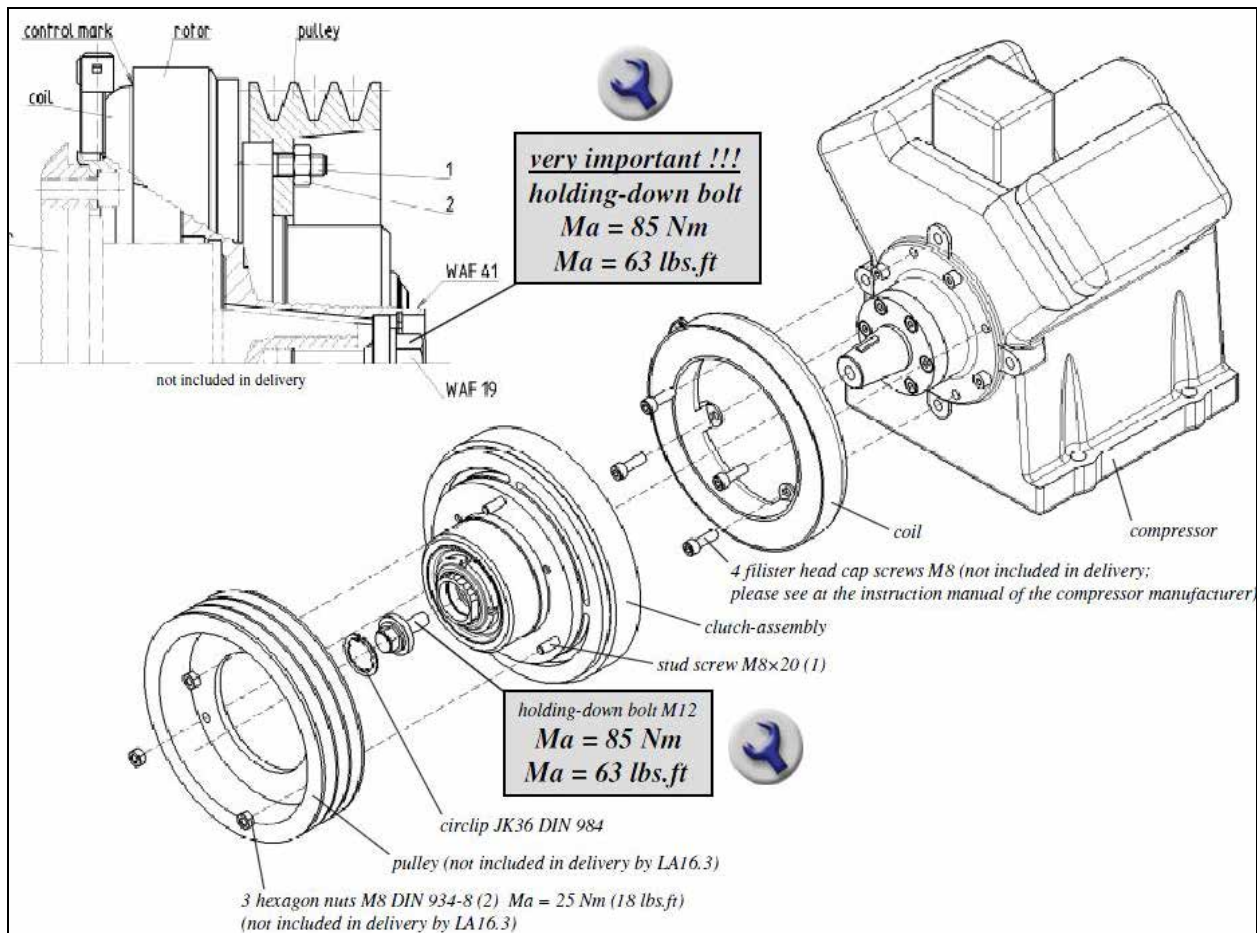

LINNIG ELECTROMAGNETIC CLUTCH INSTALLATION/REMOVAL

PART 4 –HOT SIDE SINGLE BOSCH ALTERNATOR REMOVAL AND INSTALLATION



DANGER

Park vehicle safely, apply parking brake, stop engine. Prior to working on the vehicle, **set the ignition switch to the OFF position, the battery master switch (master cut-out) to the OFF position and trip the main circuit breakers equipped with a trip button.**

RISK OF ELECTRICAL SHOCK

- The alternator is connected to the batteries through master relay R1. If the ignition switch is in the OFF position and the battery master switch (master cut-out) is set to the OFF position, there should not be electrical power to the alternator terminals. However, a faulty master relay R1 could eventually leave the battery power circuit closed, thus electrical power would be present at the alternator terminals.
- Using a multimeter, probe the alternator **B1+** terminal and the ground terminal. Make sure that the voltage reading is 0 volt prior disconnecting the alternator cables.

HOT SIDE SINGLE ALTERNATOR REMOVAL

1. Rotate the automatic belt tensioner **A** clockwise using a $\frac{1}{2}$ square drive breaker bar and then remove the alternator drive belt **B**.

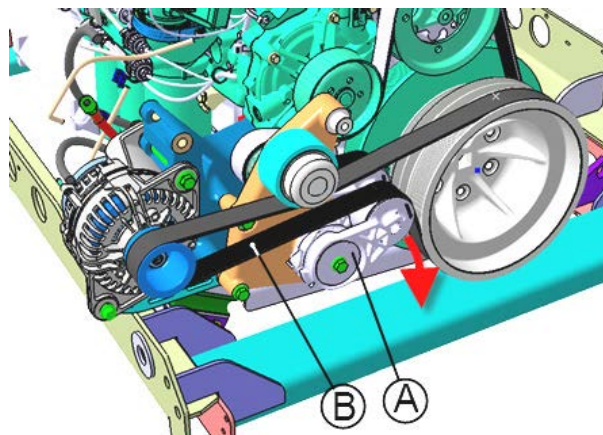

FIGURE 41

2. Cut the nylon ties securing the cables to the alternator and then disconnect the alternator cables **A**, **B** & **C**. Properly clean cable lugs as applicable using a brass wire cup brush, a Scotch-Brite pad or an emery cloth.

Keep hardware for reuse.

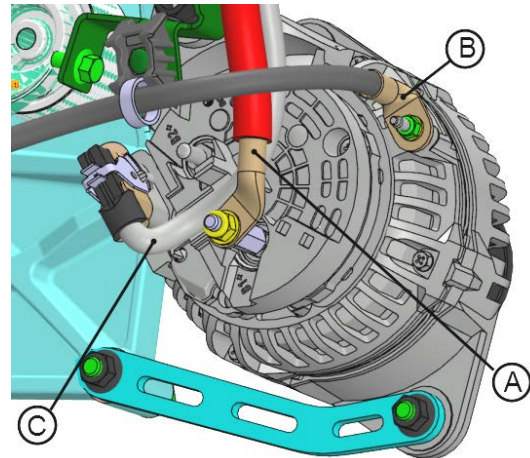

FIGURE 42

A: (+) POWER CABLE
B: GROUND CABLE
C: ALTERNATOR HARNESS

3. Remove the alternator. To do so, unscrew the two (2) mounting bolts identified on **FIGURE 43**.

Keep hardware for reuse.

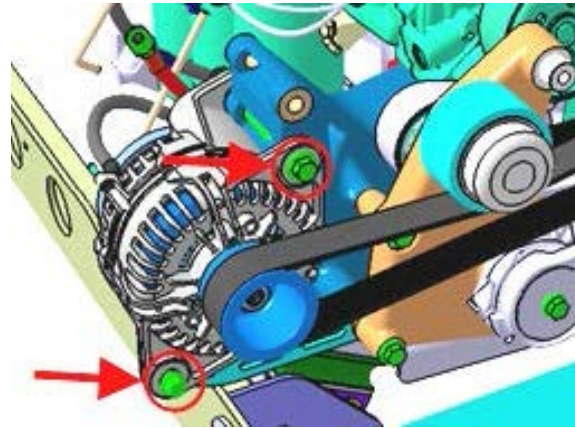

FIGURE 43

HOT SIDE ALTERNATOR INSTALLATION

4. Apply anti-seize compound (Prevost p/n: 680335) inside the alternator mounting ears and inside the sleeves found on the support attached to the engine (see **FIGURE 44** & **FIGURE 45**).

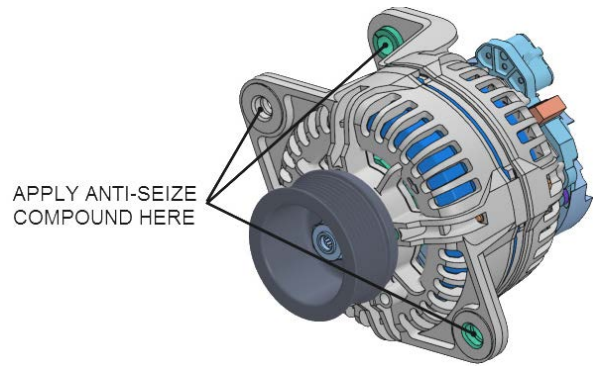

FIGURE 44

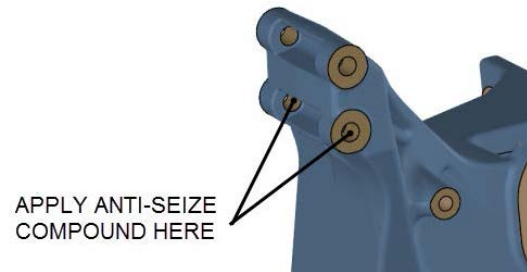

FIGURE 45

5. Reinstall the alternator using previously removed bolts **A** & **B** (**FIGURE 46**).

Use Loctite 243 Blue on threads

6. To ease installation, loosen bolt **C** if necessary (**FIGURE 46**).

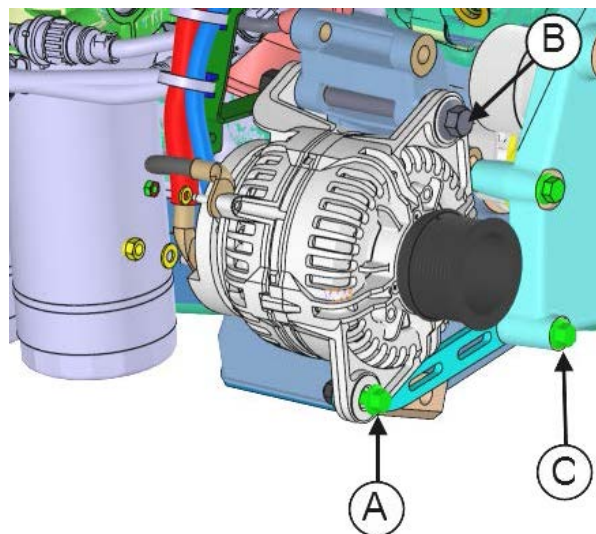

FIGURE 46

- A:** SCREW HEXF P/N 5001308 M10-1.25X40 G10.9,
NUT P/N 5001727 *torque: 48lbf-ft*
- B:** SCREW HEXF P/N 502960 M12-1.75X160 G10.9,
NUT P/N 5001728 *torque: 82 lbf-ft*
- C:** SCREW HEXF P/N 5001799 M10-1.5X70 G10.9,
NUT P/N 5001727 *torque: 48 lbf-ft*

7. Connect the (+) power cable **A**, the ground cable **B** and alternator harness **C** to the alternator (**FIGURE 47**).
8. Fit the (+) power cable terminal onto adaptor stud at **B1+** stud terminal, place one flat washer **E** against the (+) power cable lug and screw nut **D** (**FIGURE 48**).

STUD ADAPTER p/n 060297 *torque: 11 lbf-ft*

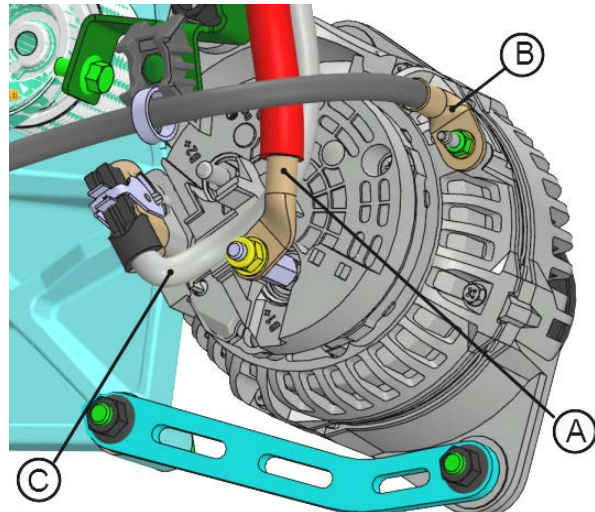

FIGURE 47

A: (+) POWER CABLE

B: GROUND CABLE

C: ALTERNATOR HARNESS

9. Connect the ground cable onto the alternator ground stud terminal as shown on **FIGURE 48**. Place one flat washer **F** against the ground cable lug terminal and screw nut **G**.

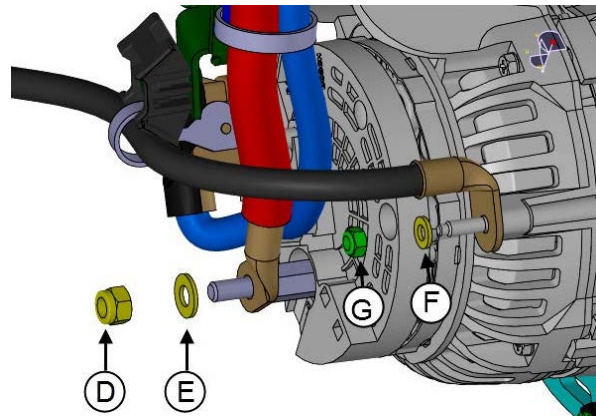

FIGURE 48

D: NUT M8 P/N 5001983 *torque: 11 lbf-ft*

E: FLAT WASHER P/N 5001341

F: FLAT WASHER P/N 502573

G: NUT M6 P/N 5001182 *torque: 6 lbf-ft*

- Secure the alternator harness using nylon cable ties P/N 504637 positioned as shown by red arrows on FIGURE 49.

NOTE: one nylon tie is used to block the connector locking mechanism in order to prevent unwanted unlocking.

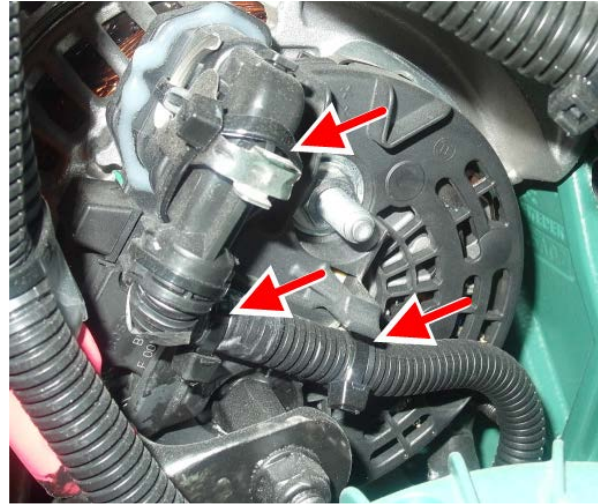

FIGURE 49

- Apply anti-corrosion compound or Color Guard Rubber Coating (Prevost p/n: 684013) on alternator studs, cable lugs and nuts.

FUNCTIONAL TEST

- Reset main circuit breakers if applicable. Set the battery master switch (master cut-out) to the ON position and start the engine. Make sure that the charging system is working normally.

On the instruments cluster, the alternator telltale  illuminates if the alternators are not charging.

PARTS / WASTE DISPOSAL

Discard according to applicable environmental regulations (Municipal/State[Prov.]/ Federal)



Access all our Service Bulletins on <https://secureus5.volvo.com/technicalpublications/en/pub.asp>
Or scan the QR-Code with your smart phone.

E-mail us at technicalpublications_prev@volvo.com and type "ADD" in the subject to receive our warranty bulletins
by e-mail.