

# Technical Service Bulletin

Mazda North American Operations  
Irvine, CA 92618-2922



<b>Subject:</b>  KEY CODE RETRIEVAL PROCEDURE	<b>Bulletin No.:</b> 09-029/18
	<b>Last Issued:</b> 06/28/2018

## DESCRIPTION

This bulletin supersedes the previously issued bulletin(s) listed below. The changes are noted in Red text.

Previous TSBs:	Date(s) Issued:
09-004/01	08/14/2001

## APPLICABLE MODEL(S)/VINS

2001-2006 Tribute

In the event that all vehicle keys are lost and the vehicle key code is not available on the Vehicle Retail Data Inquiry system, replacement keys may only be acquired by obtaining the key code using the Repair Procedure below. Mazda recommends keeping a record of all key codes at your dealership. In addition, explain to the customer that they must keep the key code tag and/or record their key code in case of lost keys.

Customers having this concern should have their vehicle repaired using the following procedure.

**CONSUMER NOTICE:** The information and instructions in this bulletin are intended for use by skilled technicians. Mazda technicians utilize the proper tools/equipment and take training to correctly and safely maintain Mazda vehicles. These instructions should not be performed by "do-it-yourselfers." Customers should not assume this bulletin applies to their vehicle or that their vehicle will develop the described concern. To determine if the information applies, customers should contact their nearest authorized Mazda dealership. Mazda North American Operations reserves the right to alter the specifications and contents of this bulletin without obligation or advance notice. All rights reserved. No part of this bulletin may be reproduced in any form or by any means, electronic or mechanical---including photocopying and recording and the use of any kind of information storage and retrieval system ---without permission in writing.

### Liftgate Key Cylinder Removal

1. Remove the key cylinder from the liftgate according to MGSS online: (LIFTGATE LOCK CYLINDER).
2. Disassemble the key cylinder.

**NOTE:** To remove the tumbler holder from tumbler case, insert a paper clip, small screwdriver, or suitable tool and make sure all tumblers are depressed. Then turn the tumbler holder counterclockwise to keep tension between the tumblers and the tumbler case.

3. Remove the tumbler holder from the tumbler case.

**NOTE:** Do not lose the spring and ball bearing.

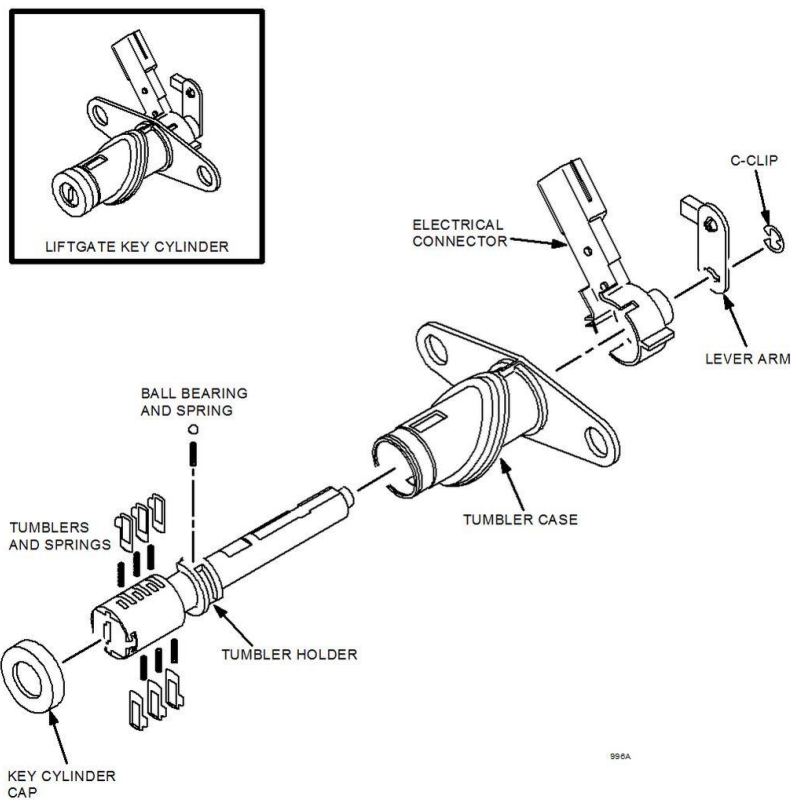

4. Remove the tumblers and write down the number stamped on each one in the order shown.

**CONSUMER NOTICE:** The information and instructions in this bulletin are intended for use by skilled technicians. Mazda technicians utilize the proper tools/equipment and take training to correctly and safely maintain Mazda vehicles. These instructions should not be performed by "do-it-yourselfers." Customers should not assume this bulletin applies to their vehicle or that their vehicle will develop the described concern. To determine if the information applies, customers should contact their nearest authorized Mazda dealership. Mazda North American Operations reserves the right to alter the specifications and contents of this bulletin without obligation or advance notice. All rights reserved. No part of this bulletin may be reproduced in any form or by any means, electronic or mechanical---including photocopying and recording and the use of any kind of information storage and retrieval system ---without permission in writing.

### Glove Box Key Cylinder Removal

1. Remove the glove box assembly.
2. Remove the glove box lock assembly (3 screws).
3. Remove the lock assembly rear cover, spring, latch and slider.

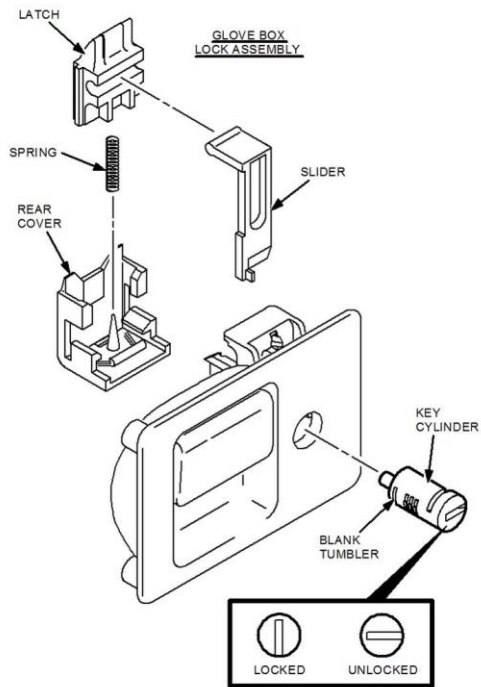

4. Remove the blank tumbler in order to remove the key cylinder, while in the lock position.

**NOTE:** Be careful not to lose the spring.

5. While depressing the remaining tumblers, turn the key cylinder to the unlock position and remove it from the lock assembly.
6. Remove the three (3) tumblers and write down the number stamped on each one according to the order shown.

**CONSUMER NOTICE:** The information and instructions in this bulletin are intended for use by skilled technicians. Mazda technicians utilize the proper tools/equipment and take training to correctly and safely maintain Mazda vehicles. These instructions should not be performed by "do-it-yourselfers." Customers should not assume this bulletin applies to their vehicle or that their vehicle will develop the described concern. To determine if the information applies, customers should contact their nearest authorized Mazda dealership. Mazda North American Operations reserves the right to alter the specifications and contents of this bulletin without obligation or advance notice. All rights reserved. No part of this bulletin may be reproduced in any form or by any means, electronic or mechanical---including photocopying and recording and the use of any kind of information storage and retrieval system ---without permission in writing.

**Obtaining the Key Code:**

1. Line up the liftgate key cylinder numbers and glove box key cylinder numbers in order, starting from the key entry side of the cylinders to obtain an eight digit number.

**NOTE:** The sixth tumbler from the liftgate cylinder is the same as the first tumbler from the glove box cylinder.

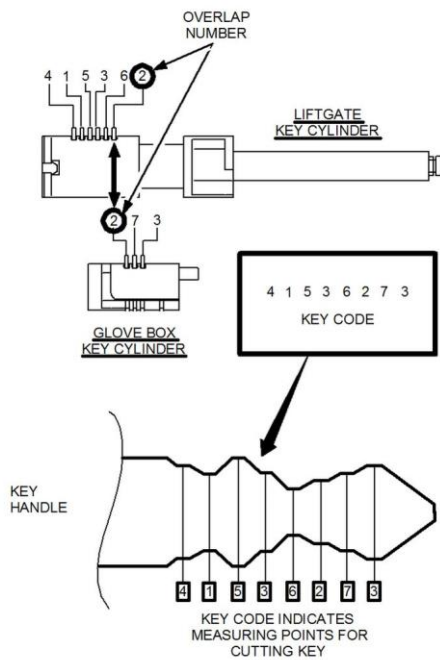
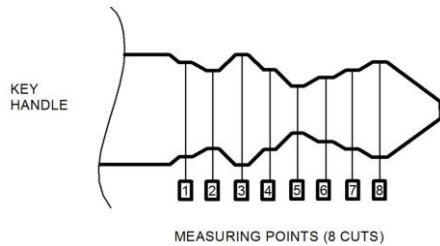

**NOTE:** If all vehicles keys are lost, a minimum of two keys must be cut and then programmed for passive anti-theft system (PATS) recognition. This will allow the vehicle to start properly.

**CONSUMER NOTICE:** The information and instructions in this bulletin are intended for use by skilled technicians. Mazda technicians utilize the proper tools/equipment and take training to correctly and safely maintain Mazda vehicles. These instructions should not be performed by "do-it-yourselfers." Customers should not assume this bulletin applies to their vehicle or that their vehicle will develop the described concern. To determine if the information applies, customers should contact their nearest authorized Mazda dealership. Mazda North American Operations reserves the right to alter the specifications and contents of this bulletin without obligation or advance notice. All rights reserved. No part of this bulletin may be reproduced in any form or by any means, electronic or mechanical---including photocopying and recording and the use of any kind of information storage and retrieval system ---without permission in writing.