

Subject: SCRATCH ON SEAT BACK BAR GARNISH FROM CONTACT WITH CONVERTIBLE TOP	Bulletin No.: 09-028/18
	Last Issued: 06/21/2018

BULLETIN NOTES

This bulletin supersedes the previously issued bulletin(s) listed below. The changes are noted below in Red.

Previously Issued TSBs:	Date(s) Issued
09-018/16	07/14/16, 04/26/16 and 03/21/16

APPLICABLE MODEL(S)/VINS

2016-2018 MX-5

DESCRIPTION

Some vehicles may exhibit scratches (1) on the rear of the seat back bar garnish (2) from contact with the convertible top (3).

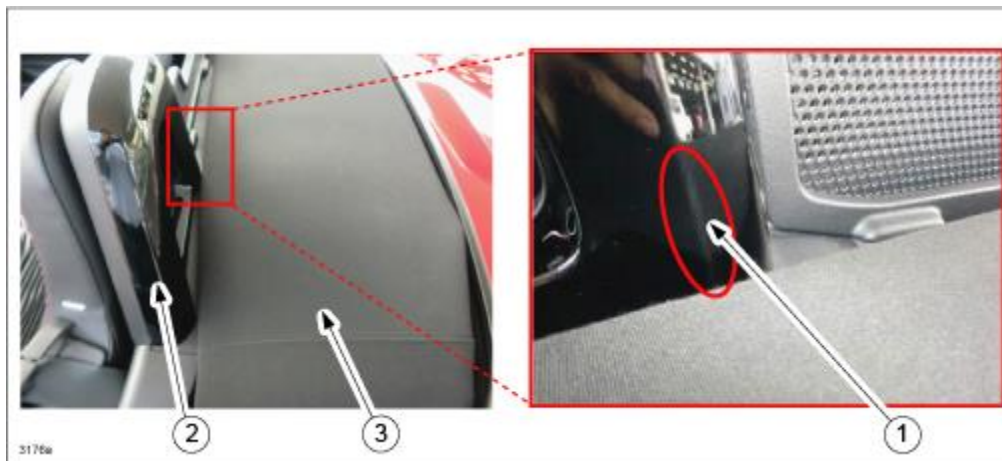

CONSUMER NOTICE: The information and instructions in this bulletin are intended for use by skilled technicians. Mazda technicians utilize the proper tools/equipment and take training to correctly and safely maintain Mazda vehicles. These instructions should not be performed by "do-it-yourselfers." Customers should not assume this bulletin applies to their vehicle or that their vehicle will develop the described concern. To determine if the information applies, customers should contact their nearest authorized Mazda dealership. Mazda North American Operations reserves the right to alter the specifications and contents of this bulletin without obligation or advance notice. All rights reserved. No part of this bulletin may be reproduced in any form or by any means, electronic or mechanical---including photocopying and recording and the use of any kind of information storage and retrieval system ---without permission in writing.

Due to assembly variations, the clearance between the seat back bar garnish and the convertible top is too small on some vehicles.



On later 2016 models (starting with VINs JM1ND*****117681), the link stopper of the convertible top has been changed to adjust the opening angle and folding position of the convertible top. This increased the gap between the seat back bar garnish and the convertible top when folded down. On these later models, the issue seems to occur if the customer does not completely lock the convertible top down when lowered.

NOTE: Make the customer aware that the top needs to be completely locked down when lowered to prevent this from happening. With the convertible top lowered, press down on both the front and rear areas of the top (as shown with the arrows) until a latch sound is heard and the top does not pop up.

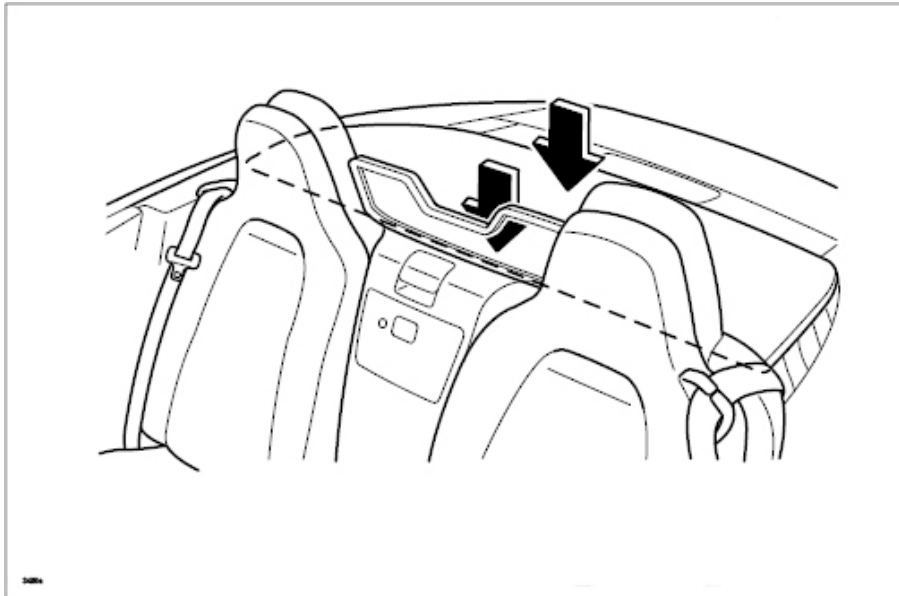

Customers having this concern should have their vehicle repaired using the following repair procedure.

CONSUMER NOTICE: The information and instructions in this bulletin are intended for use by skilled technicians. Mazda technicians utilize the proper tools/equipment and take training to correctly and safely maintain Mazda vehicles. These instructions should not be performed by "do-it-yourselfers." Customers should not assume this bulletin applies to their vehicle or that their vehicle will develop the described concern. To determine if the information applies, customers should contact their nearest authorized Mazda dealership. Mazda North American Operations reserves the right to alter the specifications and contents of this bulletin without obligation or advance notice. All rights reserved. No part of this bulletin may be reproduced in any form or by any means, electronic or mechanical---including photocopying and recording and the use of any kind of information storage and retrieval system ---without permission in writing.

REPAIR PROCEDURE

NOTE: The repair procedure is also applicable to the vehicle not included in applicable VIN range if the vehicle exhibit scratches on the seat back bar garnish (REAR).

1. Verify customer concern.
2. Remove the seat back crossmember assembly from the vehicle according to the instructions on MGSS online or the Workshop Manual (section 09-10 SEAT BACK CROSSMEMBER ASSEMBLY REMOVAL/INSTALLATION).
3. Adjust the position of the link bracket (1) for both left and right sides.
 - a. Loosen the two bolts (2) and nut (3).

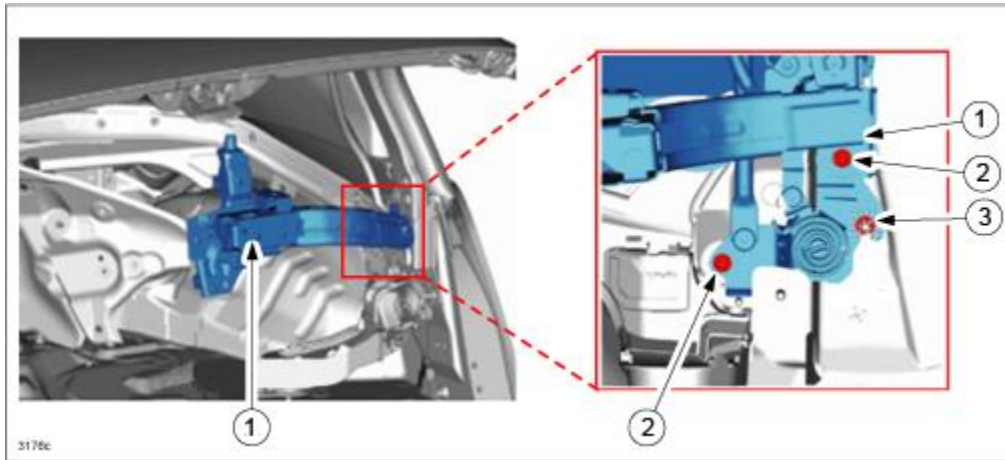

- b. Lift up the link bracket.



CONSUMER NOTICE: The information and instructions in this bulletin are intended for use by skilled technicians. Mazda technicians utilize the proper tools/equipment and take training to correctly and safely maintain Mazda vehicles. These instructions should not be performed by "do-it-yourselfers." Customers should not assume this bulletin applies to their vehicle or that their vehicle will develop the described concern. To determine if the information applies, customers should contact their nearest authorized Mazda dealership. Mazda North American Operations reserves the right to alter the specifications and contents of this bulletin without obligation or advance notice. All rights reserved. No part of this bulletin may be reproduced in any form or by any means, electronic or mechanical---including photocopying and recording and the use of any kind of information storage and retrieval system ---without permission in writing.

c. Tighten the two bolts (2) and nut (3) of the link bracket while holding it up.

Tightening torque: 19-29 N•m (2.0-2.5 kgf•m, 15-18 ft•lbf)

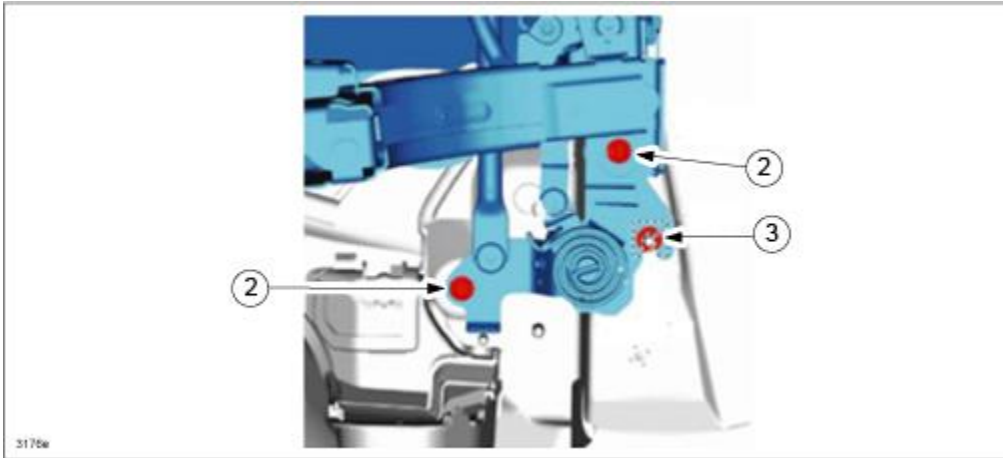

4. Attach the washers (N2Y0-R1-9YZ) to the link bracket for both left and right sides.

a. Apply a 3M Super Weatherstrip Adhesive or equivalent adhesive to the washers (1 and 2) as shown.

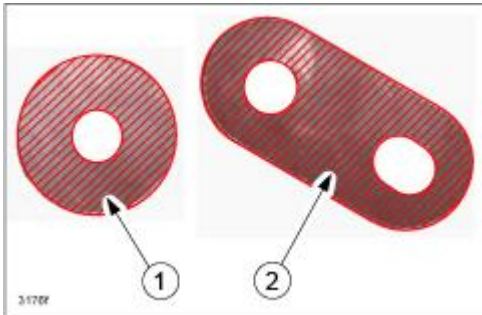

b. Apply the washers (1 and 2) to the surface of the link bracket with the adhesive.

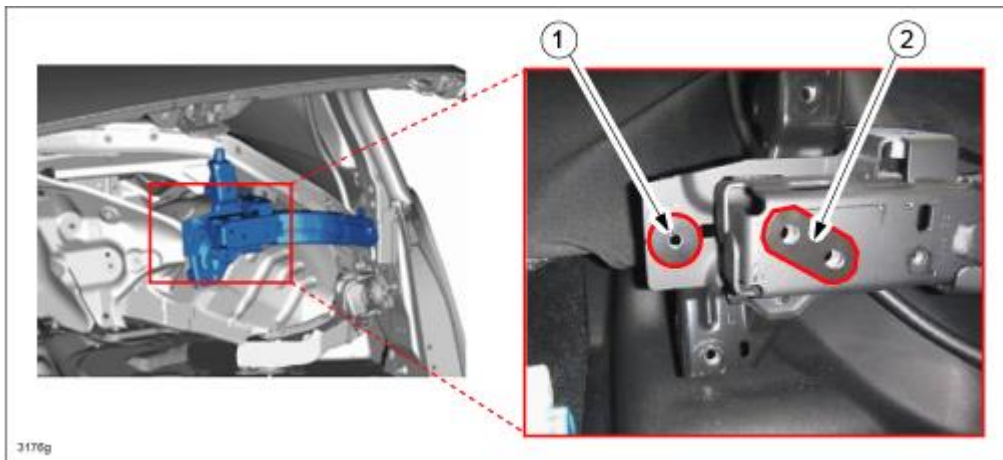

CONSUMER NOTICE: The information and instructions in this bulletin are intended for use by skilled technicians. Mazda technicians utilize the proper tools/equipment and take training to correctly and safely maintain Mazda vehicles. These instructions should not be performed by "do-it-yourselfers." Customers should not assume this bulletin applies to their vehicle or that their vehicle will develop the described concern. To determine if the information applies, customers should contact their nearest authorized Mazda dealership. Mazda North American Operations reserves the right to alter the specifications and contents of this bulletin without obligation or advance notice. All rights reserved. No part of this bulletin may be reproduced in any form or by any means, electronic or mechanical---including photocopying and recording and the use of any kind of information storage and retrieval system ---without permission in writing.

NOTE: Install washer B (2) with the ellipsoid hole (3) placed as shown

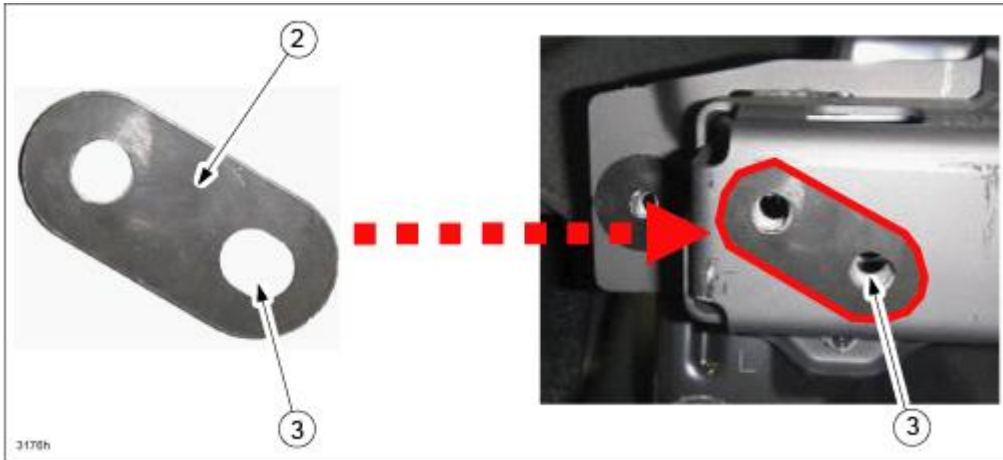

5. Attach 8 pieces of fabric sheet to the 4 square holes of the seat back crossmember to prevent a creak noise.

NOTE: The holes may be damaged when removing the metal fasteners of the back trim from the square holes of the seat back crossmember. A loose fit of these fasteners could cause a creak noise.

a. Select a 0.25 mm thickness fabric sheet from the "Noise Repair Kit" (TA01-76-100) and cut out 8 equal squares 15mm x 10mm.

NOTE: If the "Noise Repair Kit" is not available, obtain an appropriate fabric sheet locally.

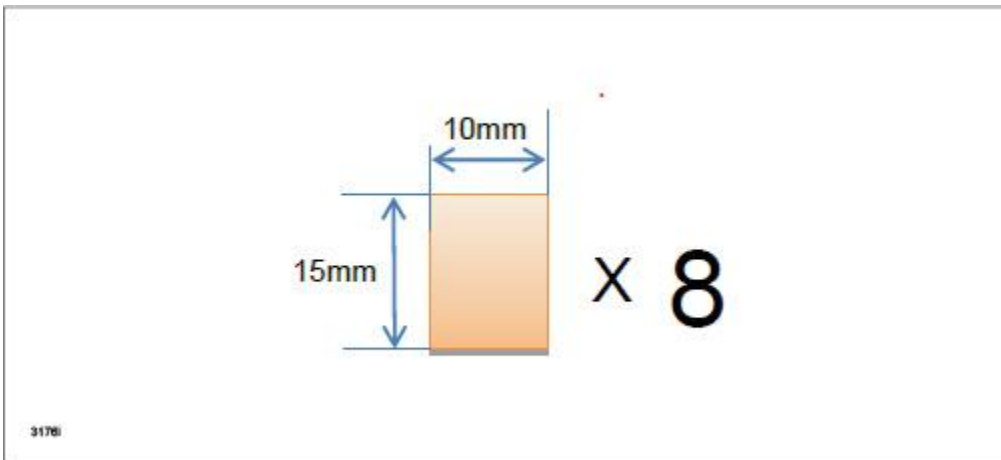

CONSUMER NOTICE: The information and instructions in this bulletin are intended for use by skilled technicians. Mazda technicians utilize the proper tools/equipment and take training to correctly and safely maintain Mazda vehicles. These instructions should not be performed by "do-it-yourselfers." Customers should not assume this bulletin applies to their vehicle or that their vehicle will develop the described concern. To determine if the information applies, customers should contact their nearest authorized Mazda dealership. Mazda North American Operations reserves the right to alter the specifications and contents of this bulletin without obligation or advance notice. All rights reserved. No part of this bulletin may be reproduced in any form or by any means, electronic or mechanical---including photocopying and recording and the use of any kind of information storage and retrieval system ---without permission in writing.

b. Clean and degrease the area (1) around the four square holes (2) of the seat back crossmember.

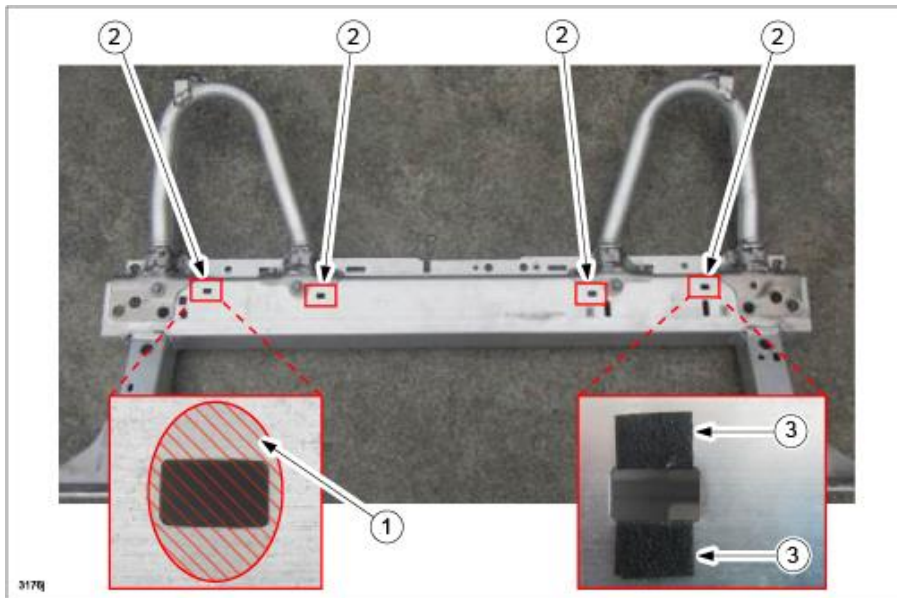

c. Attach a piece of fabric sheet to the top and bottom (3) of the four square holes.

6. Install the seat back crossmember assembly from the vehicle according to the instructions on MGSS online or the Workshop Manual (section 09-10 SEAT BACK CROSSMEMBER ASSEMBLY REMOVAL/INSTALLATION).

7. Reinstall the rear seat back bar garnish while twisting the garnish so that the garnish can be kept closer to the seat back bar and away from the convertible top (for both left and right sides).

NOTE: Left side is shown.

a. Loosen the screw (1) of the rear seat back bar garnish.

NOTE: If the seat back bar garnish(s) is scratched, replace it with a new one.



CONSUMER NOTICE: The information and instructions in this bulletin are intended for use by skilled technicians. Mazda technicians utilize the proper tools/equipment and take training to correctly and safely maintain Mazda vehicles. These instructions should not be performed by "do-it-yourselfers." Customers should not assume this bulletin applies to their vehicle or that their vehicle will develop the described concern. To determine if the information applies, customers should contact their nearest authorized Mazda dealership. Mazda North American Operations reserves the right to alter the specifications and contents of this bulletin without obligation or advance notice. All rights reserved. No part of this bulletin may be reproduced in any form or by any means, electronic or mechanical---including photocopying and recording and the use of any kind of information storage and retrieval system ---without permission in writing.

b. Tighten the screw while twisting the rear seat back bar garnish (1) in the direction shown.



8. Install the removed parts in the reverse order of removal.

9. Verify repair.

PARTS INFORMATION

Part Number	Description	Qty.	Notes
N243-69-732A	Garnish (R), Rear	1	Right side
N243-69-742A	Garnish (L), Rear	1	Left side
N2Y0-R1-9YZ	Repair Kit	1	4 Washers
TA01-76-100	Noise Repair Kit	1	Repairs 9 vehicles

CONSUMER NOTICE: The information and instructions in this bulletin are intended for use by skilled technicians. Mazda technicians utilize the proper tools/equipment and take training to correctly and safely maintain Mazda vehicles. These instructions should not be performed by "do-it-yourselfers." Customers should not assume this bulletin applies to their vehicle or that their vehicle will develop the described concern. To determine if the information applies, customers should contact their nearest authorized Mazda dealership. Mazda North American Operations reserves the right to alter the specifications and contents of this bulletin without obligation or advance notice. All rights reserved. No part of this bulletin may be reproduced in any form or by any means, electronic or mechanical---including photocopying and recording and the use of any kind of information storage and retrieval system ---without permission in writing.

WARRANTY INFORMATION

NOTE:

- This warranty information applies only to verified customer complaints on vehicles eligible for warranty repair.
- This repair will be covered under Mazda's New Vehicle Limited Warranty.
- Additional diagnostic time cannot be claimed for this repair.

Warranty Type	A
Symptom Code	90
Damage Code	9A
Part Number Main Cause / Qty.	N247-R1-210-J02 / 0
Operation Number / Labor Hours:	XXM2TBRX / 1.3 Hrs.

CONSUMER NOTICE: The information and instructions in this bulletin are intended for use by skilled technicians. Mazda technicians utilize the proper tools/equipment and take training to correctly and safely maintain Mazda vehicles. These instructions should not be performed by "do-it-yourselfers." Customers should not assume this bulletin applies to their vehicle or that their vehicle will develop the described concern. To determine if the information applies, customers should contact their nearest authorized Mazda dealership. Mazda North American Operations reserves the right to alter the specifications and contents of this bulletin without obligation or advance notice. All rights reserved. No part of this bulletin may be reproduced in any form or by any means, electronic or mechanical---including photocopying and recording and the use of any kind of information storage and retrieval system ---without permission in writing.