



Date	Group	No.	Release	Page
7.2018	221	012	01	1(8)

Oil Fill Adapter, Replacement
CHU, GU, PI, GR, CSM, CMM, CMH, CXX,
CLX

FSB 221-012, Oil Fill Adapter, Replacement

(July 2018)

Some Mack CHU, GU, PI, GR, CSM, CMM, CMH, CXX, and CLX vehicles built between January 1, 2017 and February 1, 2018 may show signs of debris infiltration at the oil fill tube. This condition is caused by improper fit of the oil fill adapter. If visible signs of debris infiltration are present, replacement of the oil fill adapter is recommended. Follow the oil fill adapter replacement procedure outlined in this Field Service Bulletin (FSB).

Note: This bulletin also applies to MACK Trucks Australia.

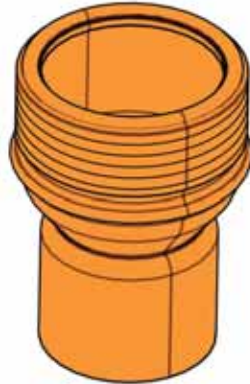

W2136983

Required Parts			
Item	Description	Part Number	Qty
1	Oil Fill Adapter	23341647	1

Decommissioning the Truck for Repair

You must read and understand the precautions and guidelines in Service Information, group 20, "General Safety Practices, Engines" before performing this procedure. If you are not properly trained and certified in this procedure, ask your supervisor for training before you perform it.

NOTE: Information is subject to change without notice. Illustrations are used for reference only and can differ slightly from the actual vehicle being serviced. However, key components addressed in this information are represented as accurately as possible.

- 1 Park the vehicle on a flat and level surface.
- 2 Apply the parking brake.
- 3 Place the transmission in neutral or park.
- 4 Chock the front wheels.

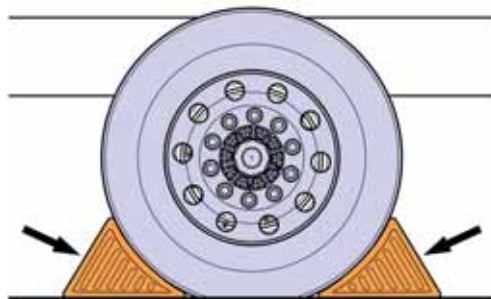

W7086748

- 5 Disconnect the cables.

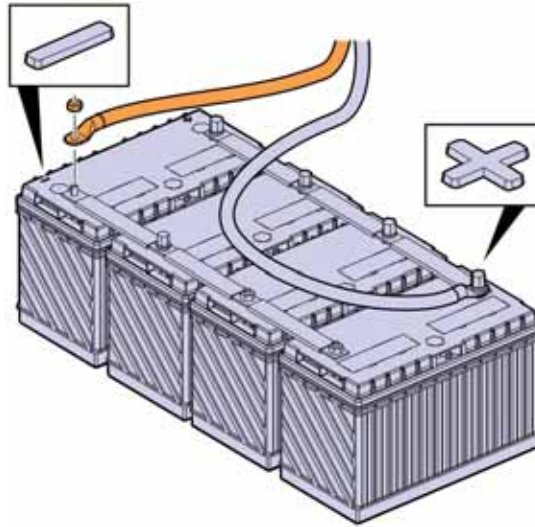

W3086747

Oil fill Adapter Replacement Procedure

- 1 Open the hood.
- 2 Loosen the clamp securing the oil fill adapter to the oil fill tube.

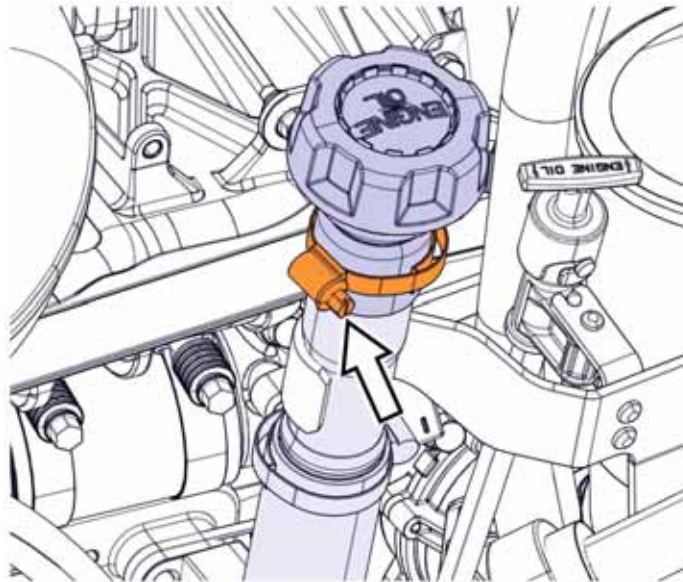

W2136984

- 3 Remove the oil fill adapter from the oil fill tube.

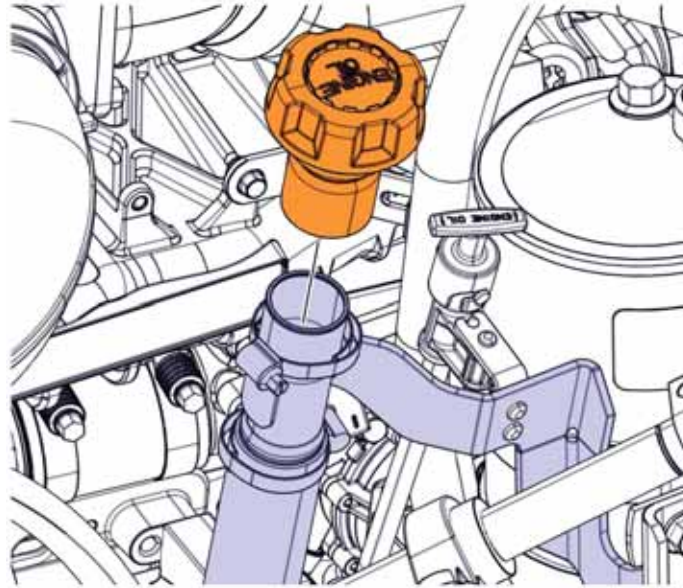

W2136985

- 4 Remove the cap from the oil fill adapter as shown in the figure below and store for reuse.

Note: Some caps come equipped with a rubber retaining strap securing the to the adapter. If applicable, carefully remove the and retainer strap from the adapter.

Note: Check inside of the cap to ensure that the inner seal is present and in serviceable condition.

Note: Clean the entire cap and inner seal of any debris.

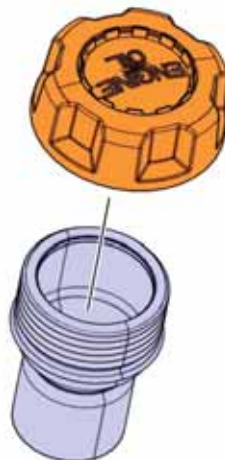

W2136986

- 5 Install the cap on the replacement oil fill adapter (part number 23341647) as shown in the figure below.

Note: Some caps come equipped with a rubber retaining strap securing the cap to the adapter. If applicable, carefully install the cap and retainer strap on the adapter.

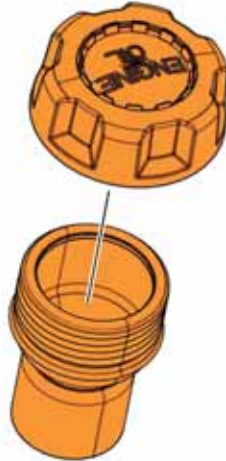

W2136987

- 6 Inspect the fill tube for debris. If debris is present, clean the fill tube to prevent contaminants from reaching the oil sump.

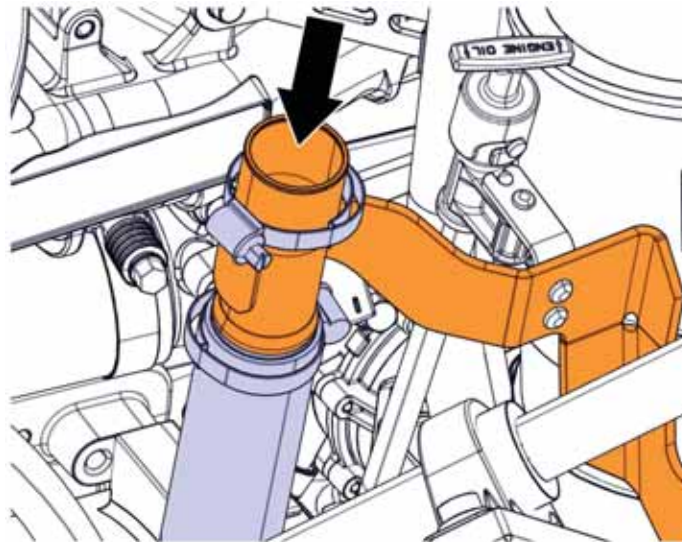

W2136988

7 Position the oil fill adapter on the oil fill tube.

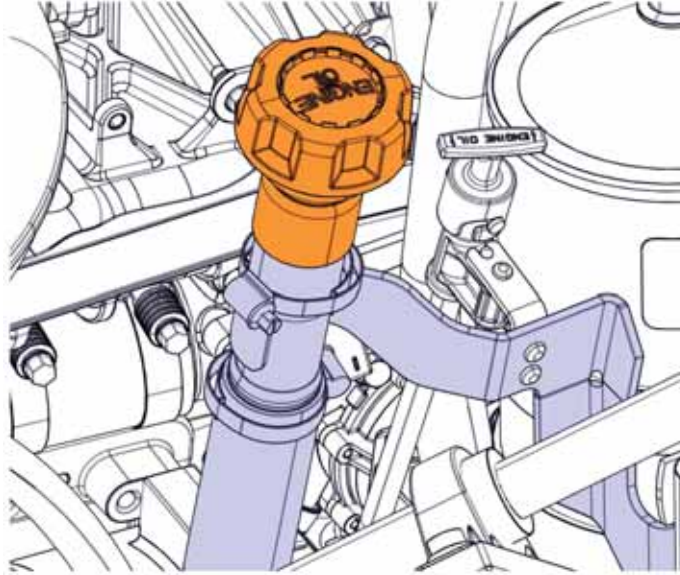

W2136989

8 Position the clamp on the oil fill adapter and tighten the clamp to 5 Nm (45 in-lb).

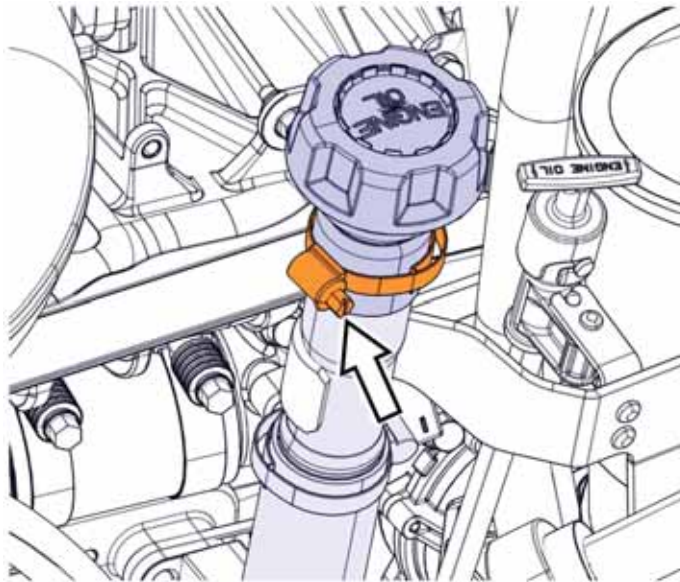

W2136984

9 Close the hood.

Commissioning the Truck for Operation

1 Connect the battery cables.

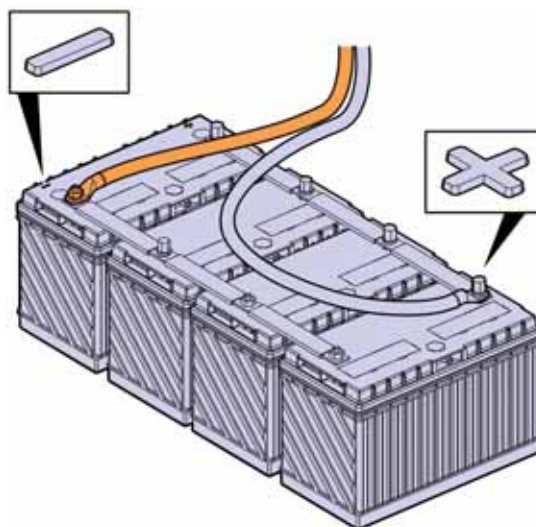

W3086758

2 Remove the wheel chocks.

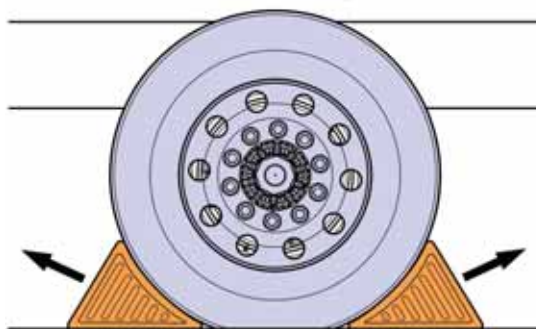

W7086759

Reimbursement

This repair may be eligible for reimbursement if a product failure was experienced within time and mileage limits of the applicable Warranty coverage. Reimbursement is obtained via the normal claim handling process.	UCHP Reimbursement
Claim Type (used only when uploading from the Dealer Bus. Sys.)	01
Labor Code	
Primary Labor Code (Oil fill Adapter Replacement)	2215-05-09-02 0.3 hrs.
Causal Part	20584182

MACK Trucks North America reserves the right to make any changes in design or to make additions to or upon its products without incurring any obligations to install the same on vehicles previously built.