



# MAINTENANCE INFORMATION

**MI18-18**

DATE :	June 2018	SECTION : 18 BODY
SUBJECT :	<b>GENERAL HOISTING AND TOWING PROCEDURES</b>	

First Release

## APPLICATION

All PrevoSt vehicles models Model Year : 2014 - Current
--

## DESCRIPTION

This maintenance information is for towing and hoisting PrevoSt vehicles.

Tower experience, local rules and regulations apply in conjunction with the procedures outlined in this document.

Images are for representation purpose only, actual vehicles may differ.

## Table of contents

<b>1. HOISTING AND TOWING POINTS .....</b>	<b>2</b>
1.1 JACK STANDS.....	3
1.2 AXLE HOISTING POINTS.....	4
1.3 USING WHEELS AS LIFTING POINTS.....	6
1.4 OPTIONAL CHASSIS HOISTING POINTS.....	7
<b>2. TOWING.....</b>	<b>9</b>
2.1 PREPARATION BEFORE TOWING.....	9
2.1.1 Engine compartment emergency air-fill valve.....	10
2.1.2 X Series optional front air supply connections.....	10
2.1.3 Drive Axle Flange Shaft Removal.....	11
2.1.4 After Towing.....	13
2.2 TOWING FROM THE FRONT .....	13
2.2.1 First Lift.....	14
2.2.2 Second Lift- Front Tow Eye Pads as Lifting Point for Towing.....	15
2.2.3 Second Lift- Using I-Beam Front Axle as Lifting Point for Towing .....	18
2.3 X-SERIES RECOVERY USING OPTIONAL REAR TOW EYES .....	22
<b>3. EMERGENCY TOWING .....</b>	<b>23</b>
3.1 REAR TOW USING NON-APPROVED LIFTING POINTS - EMERGENCY ONLY .....	23
3.1.1 PRECAUTIONS.....	23
3.1.2 FIRST LIFT.....	24
3.1.3 SECOND LIFT.....	25
3.2 VOLVO I-SHIFT TRANSMISSION TOWING MODE .....	29

## 1. HOISTING AND TOWING POINTS

As much as possible, use the wheels as the preferred lifting points. If lifting by the wheels is not possible or appropriate, there are several hoisting and towing points under the vehicle.

Lifting should be performed without passengers and no luggage remaining in the vehicle.

Use these points exclusively for hoisting and towing operations (Figure 1, Figure 2).

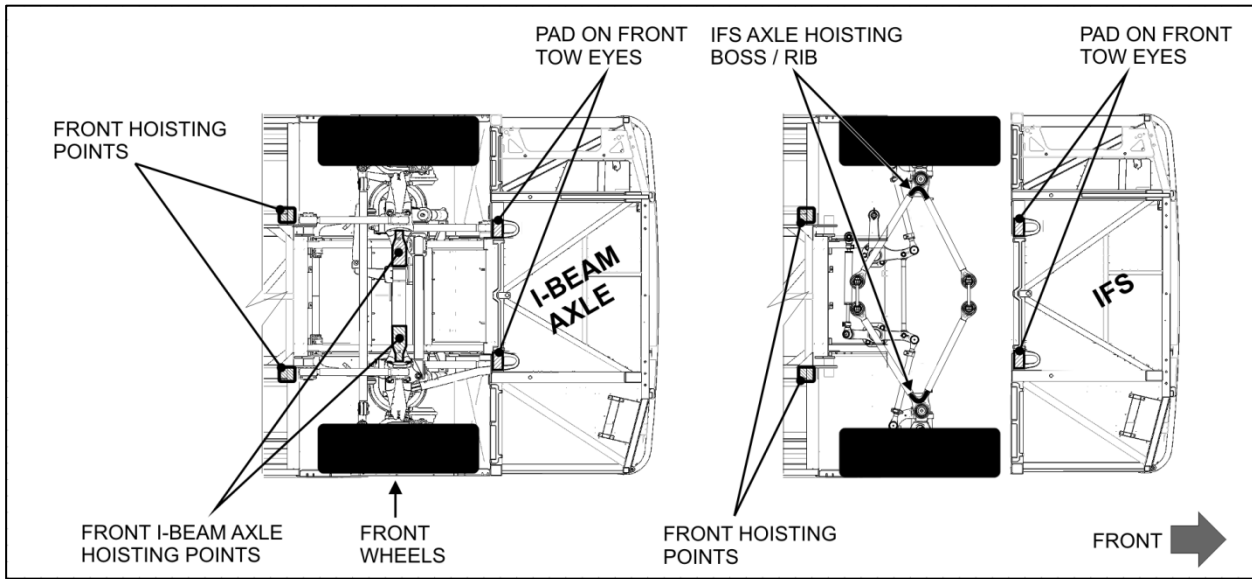

FIGURE 1 FRONT HOISTING AND LIFTING POINTS DIAGRAM

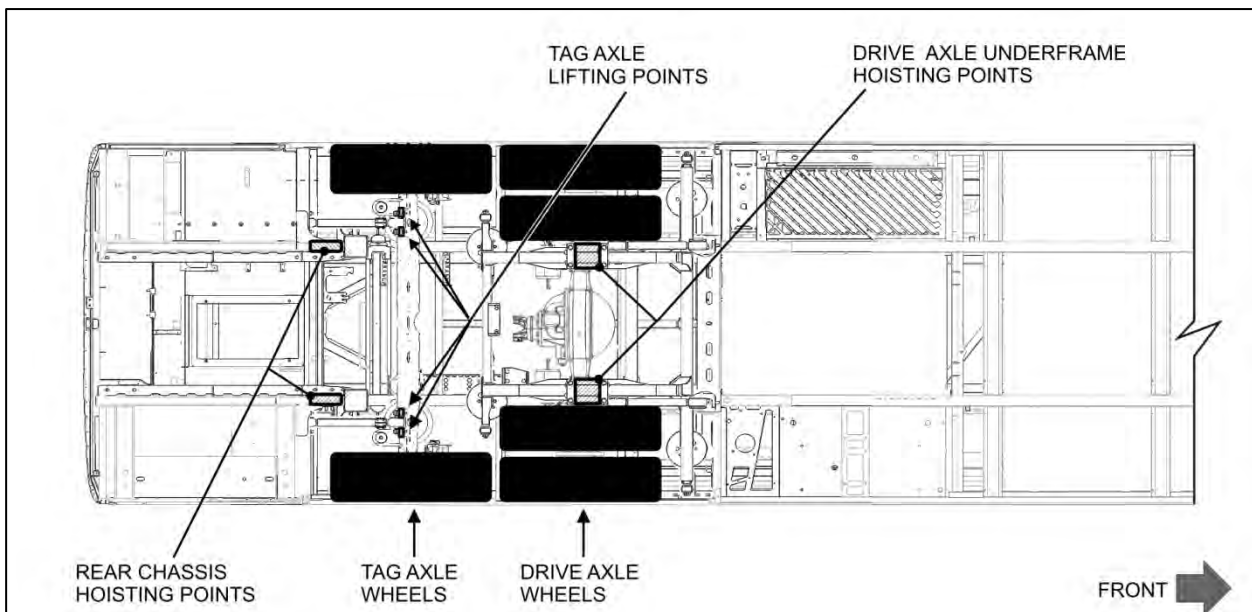

FIGURE 2 REAR HOISTING AND LIFTING POINTS DIAGRAM

The vehicle is provided with four standard chassis hoisting points. When axles or wheels are serviced, use the chassis hoisting points.

When using the chassis hoisting points to support the vehicle, **the tag axle must be unloaded at all times**. To prevent damage to the suspension, **always support the drive and front axles using jack stands** when using chassis hoisting points.

CHASSIS HOISTING POINTS
2 hoisting points located aft of the tag axle (Figure3)
2 hoisting points or optional hoisting pads with receptacles located aft of the front axle (Figure4)



FIGURE 3 : CHASSIS HOISTING POINTS  
- AFT OF TAG AXLE (BOTH SIDES)



FIGURE 4 : JACK STAND AT CHASSIS HOISTING  
POINT - AFT OF FRONT AXLE (BOTH SIDES)

### 1.1 JACK STANDS

As a general recommendation, the minimum safe working load (SWL) for any jack stand should be 10 US tons (20 000 lb; 9072 kg). Figure5, Figure6 and Figure7 show general examples of this type of jack stand.

The vehicle can be supported at the chassis hoisting points (refer to HOISTING AND LIFTING POINTS diagram). Use a jack stand of 10 US tons (20 000 lb; 9072 kg) capacity at each of the four standard chassis hoisting points.

 <b>WARNING</b>
Hydraulic jacks are intended for lifting only. Do not get under the vehicle while using hydraulic jacks unless it is properly supported with safety jack stands.



FIGURE 5 : 20 000 LB (10 US TON) CAPACITY JACK STAND



FIGURE 6 : 16500 LBF CAPACITY



FIGURE 7 : 40 000 LB (20 US TON) CAPACITY JACK STAND

## 1.2 AXLE HOISTING POINTS

AXLE HOISTING POINTS
2 front axle hoisting points (Figure8, Figure9, Figure10)
2 drive axle sub frame hoisting points (Figure11)
2 hoisting points under the tag axle (tag axle must be unloaded) (Figure12)

To ensure stability, always use the two hoisting points under a specific axle simultaneously.

 <b>WARNING</b>
Two hoisting points are located under the tag axle. Using the tag axle as rear hoisting points for the vehicle should be avoided. When possible, use the drive axle as hoisting point.

The vehicle can be lifted from the front axle and the drive axle sub frame using lifting equipment of appropriate capacity.

APPROXIMATE WEIGHT PER AXLE	
COACHES	MOTORHOMES / SPECIALTY VEHICLES
Front axle: 12,000 lb. (5 443 kg) Drive axle: 26,500 lb. (12 020 kg)	Contact the owner of the vehicle. The Gross Axle Weight Rating (GAWR) for the front and rear axle should not be exceeded. GAWR values for a particular vehicle appear on the vehicle's certification plate installed on the driver's left-hand console.

 <b>WARNING</b>
The suspension must be in the normal ride position before hoisting.

 <b>WARNING</b>
To prevent damage to suspension components, always unload the tag axle before hoisting the vehicle.

### FRONT AXLE HOISTING POINTS

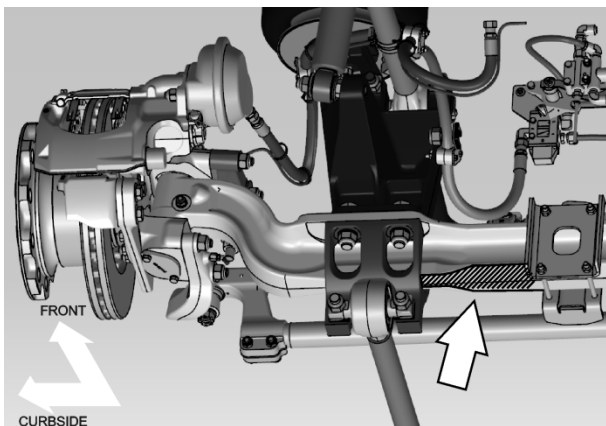

FIGURE 8 : I-BEAM AXLE HOISTING POINT - CURBSIDE

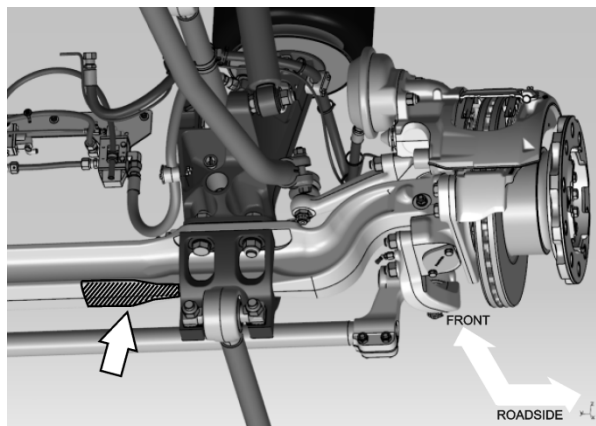

FIGURE 9 : I-BEAM AXLE HOISTING POINT - ROAD SIDE

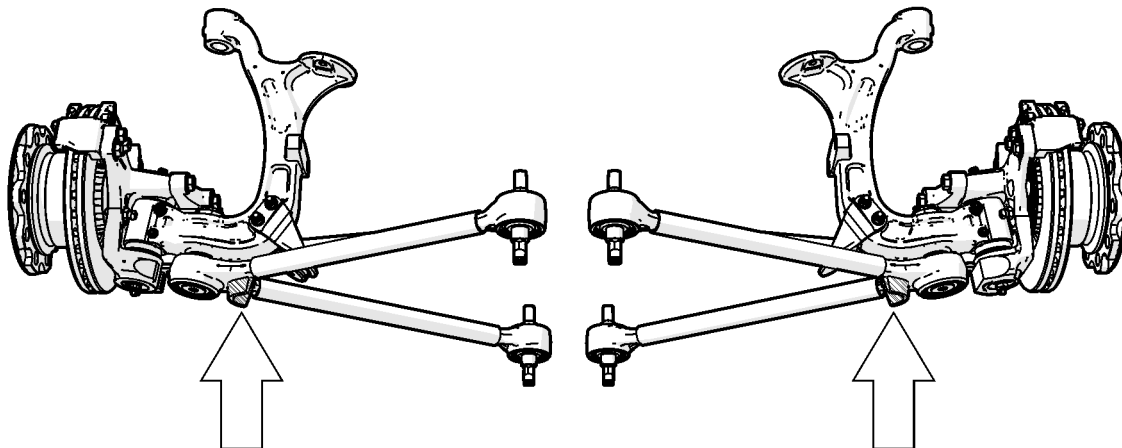

FIGURE 10 : INDEPENDENT FRONT SUSPENSION (IFS) HOISTING POINTS.

### DRIVE AXLE SUB FRAME HOISTING POINTS

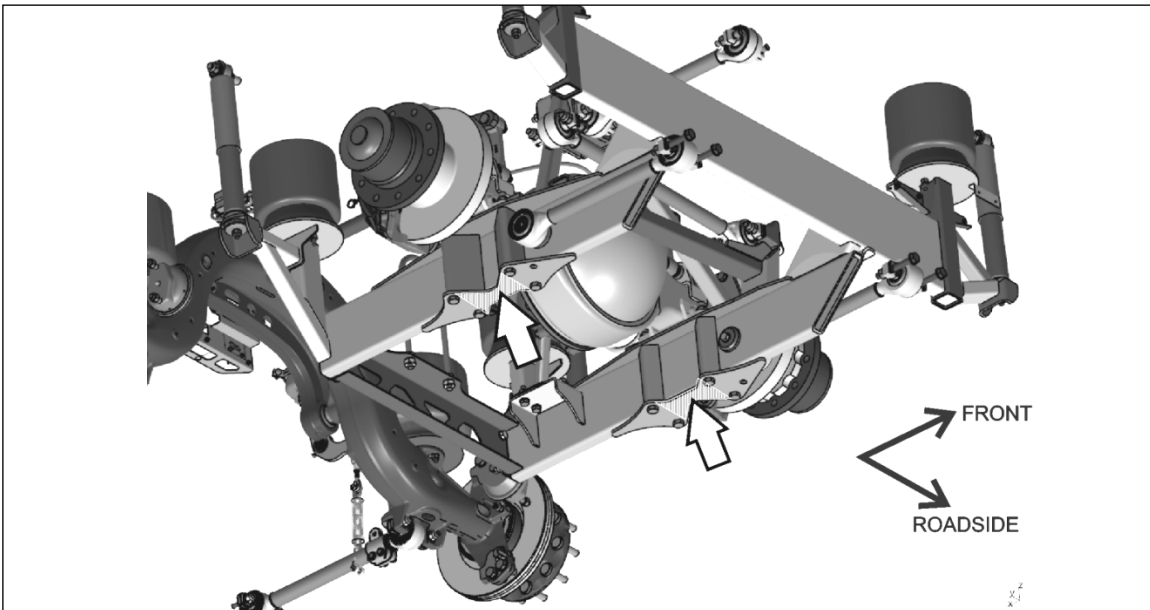

FIGURE 11 : DRIVE AXLE SUB FRAME HOISTING POINTS.

### TAG AXLE HOISTING POINTS

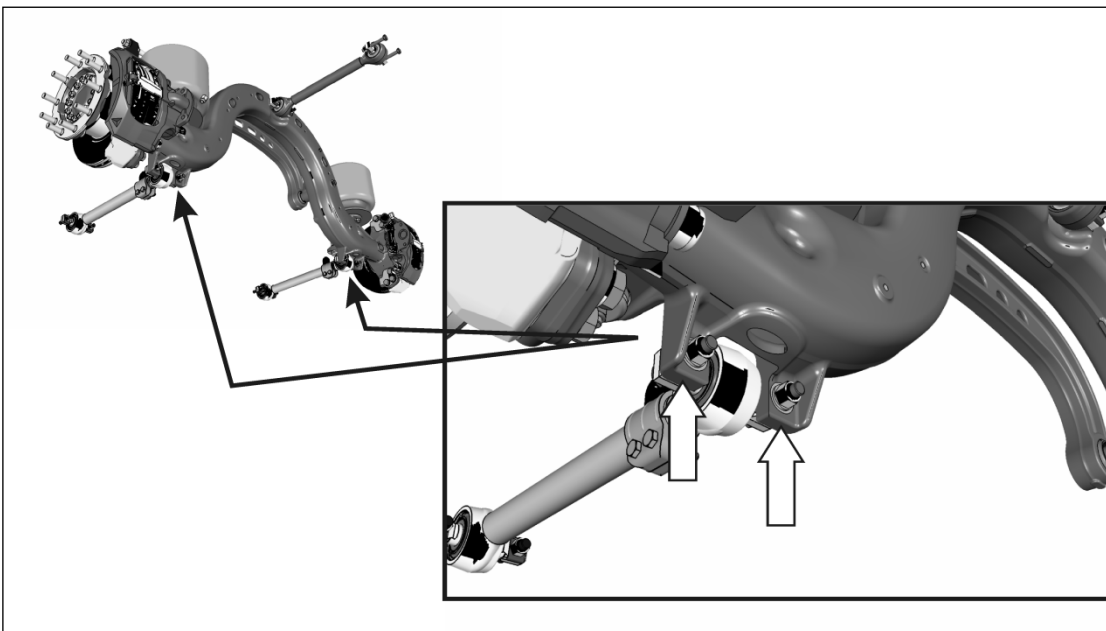

FIGURE 12 : TAG AXLE HOISTING POINTS (USE ONLY TO SUPPORT THE TAG AXLE)

### 1.3 USING WHEELS AS LIFTING POINTS

Use the front and drive axle wheels to lift the vehicle when using mobile column lifts. When doing so, the tag axle must be unloaded at all time.

Avoid using the tag axle wheels as the only lifting point for the rear of the vehicle. However, if the rear of the vehicle has to be lifted using the tag axle wheels, the tag axle must be unloaded at all times.

#### 1.4 X-SERIES COMMUTER OPTIONAL CHASSIS HOISTING POINTS

On certain vehicles, lifting pads and rear emergency recovery toe eyes may be added on the chassis. When axles or wheels are serviced, use the chassis hoisting points.

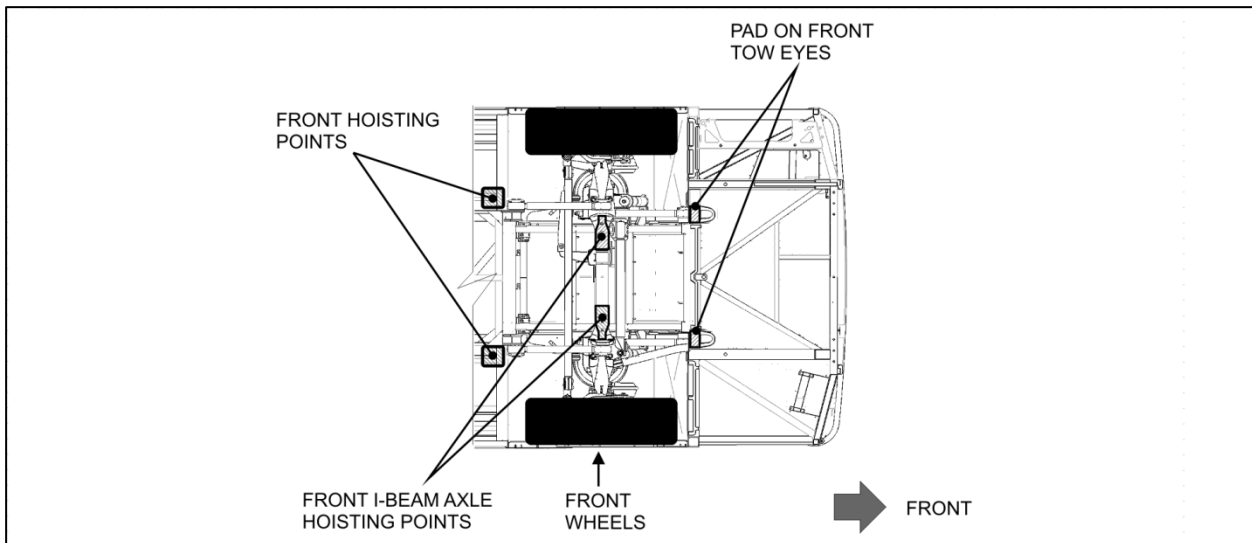

FIGURE 13 : OPTIONAL FRONT CHASSIS HOISTING POINTS

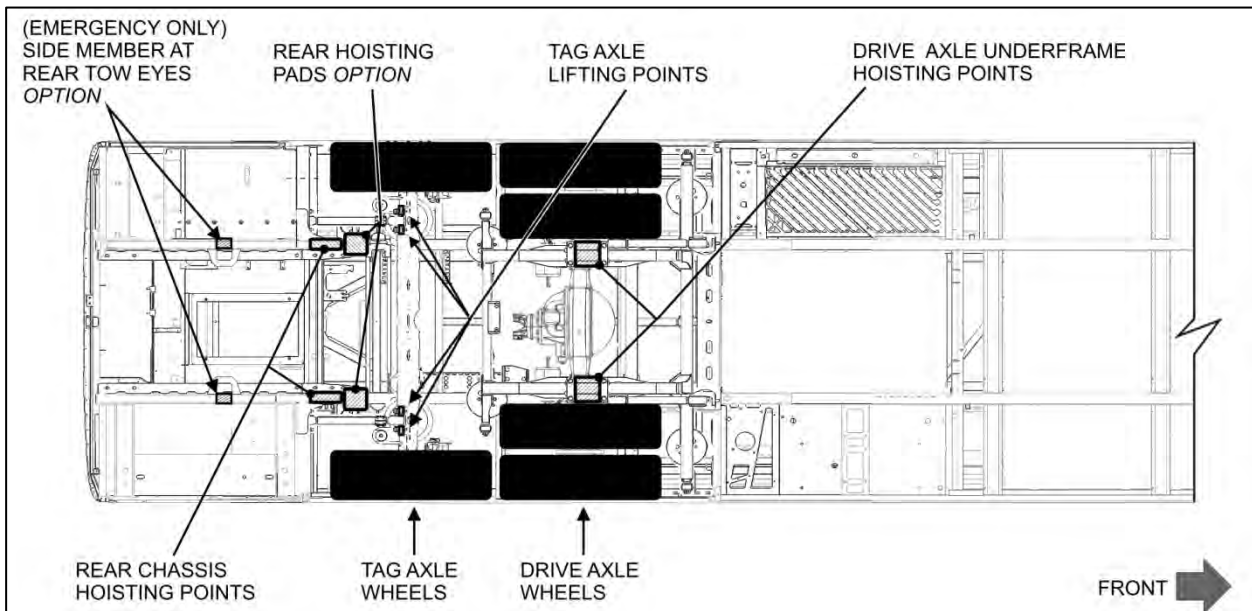

FIGURE 14 : X-SERIES OPTIONAL REAR CHASSIS HOISTING POINTS

When using the chassis hoisting points to support the vehicle, the tag axle must be unloaded at all times. To prevent damage to the suspension, always support the drive and front axles using jack stands when using chassis hoisting points.

X-SERIES OPTIONAL CHASSIS HOISTING POINTS
2 hoisting points located aft of the tag axle (Figure 15)
2 optional hoisting pads with receptacles located aft of the front axle (Figure 16)
2 optional hoisting pads with receptacles located aft of the tag axle (Figure 15)



**FIGURE 15 : OPTIONAL CHASSIS HOISTING RECEPTACLES - AFT OF TAG AXLE**



**FIGURE 16 : OPTIONAL CHASSIS HOISTING RECEPTACLES - AFT OF FRONT AXLE**



**FIGURE 17 : JACK STAND AT CHASSIS HOISTING RECEPTACLE - AFT OF FRONT AXLE, ROAD SIDE**



**FIGURE 18 : JACK STAND AT CHASSIS HOISTING RECEPTACLE - AFT OF FRONT AXLE, CURB SIDE**



**FIGURE 19 : JACK STAND AT CHASSIS HOISTING RECEPTACLE - AFT OF TAG AXLE, ROAD SIDE**



**FIGURE 20 : JACK STAND AT CHASSIS HOISTING RECEPTACLE - AFT OF TAG AXLE, CURB SIDE**

## 2. TOWING

Towing from the front is the recommended method. Prevost does not recommend towing from the rear using unapproved hoisting points as the vehicle may sustain structural damage.

Observe normal precautions including, but not limited to list below:

- Make sure the parking brake or the emergency brake is released at time of towing.
- Do not allow passengers to ride on board.
- Tow the vehicle at a safe speed.
- Accelerate and decelerate slowly and cautiously.
- Avoid sharp turns where possible.



### WARNING

Do not carry passengers while the vehicle is being towed.



### CAUTION

Avoid towing the vehicle from the rear using hoisting points that are not approved as this will cause structural damage. In case of damage to the drive train components use a low-bed semi-trailer.



### WARNING

Engage the parking brake to prevent the vehicle from moving before you begin maintenance or service procedures that require you to be under the vehicle. Serious personal injury can result.



### CAUTION

Lift the vehicle at the minimal height required for the vehicle to trail the tow truck.

### 2.1 PREPARATION BEFORE TOWING



### WARNING

Prior to hoisting, park the vehicle on a level surface and apply parking brake.

Chock the wheels to prevent the vehicle from moving at time of releasing the parking brake during the towing preparation.

On the L.H. dashboard panel, turn on the hazard warning flashers. Preferably, use a towing light bar.



FIGURE 21

Place the front wheels in a straight-ahead position and keep the steering wheel from turning. To do so, slide the driver's seat close to the steering wheel. Wrap the safety belt around and through the steering wheel and then fasten safety belts.

This will ensure the vehicle rolls in straight direction to be stopped by the tow truck in case of mechanical failure of the lifting equipment.



FIGURE 22

**2.1.1 Engine compartment emergency air-fill valve**

Use the emergency fill valve to supply air to the system when the engine cannot be operated. This valve is located in the engine compartment (Figure23) and supplies air for all systems (brakes, suspension and accessories).



FIGURE 23 : ENGINE COMPARTMENT EMERGENCY AIR-FILL VALVE

	<b>CAUTION</b>
<p>Do not tow the vehicle without external air pressure applied to the emergency fill valve if the engine does not operate. Without brake system air pressure, the emergency spring brakes may apply automatically. If failure prevents releasing the parking brakes with air pressure, disengage the parking brakes mechanically.</p>	

**2.1.2 X Series Optional Front Air Supply Connections**

Operate the engine when towing to maintain brake system air pressure. If the engine cannot be operated, connect external air pressure lines from the tow truck.

**“Brake” quick connect fitting**

Flip down the access door located on the front bumper, connect an auxiliary air supply from the tow truck to the quick connect fitting identified BRAKE in order to supply air for operation of the vehicle **service brake** from the tow truck (Figure24, Figure25).

**“Air supply” quick connect fitting**

While the vehicle is being towed, connect an auxiliary air supply from the tow truck to the quick connect fitting identified AIR SUPPLY to supply air for all systems (brakes, suspension, accessories) through the air dryer (Figure24, Figure25).



FIGURE 24

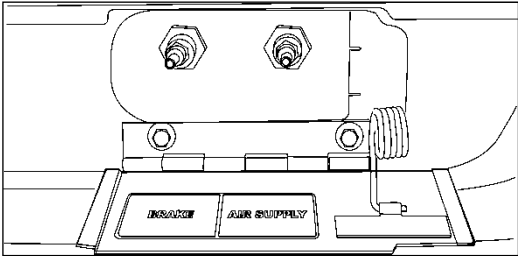

FIGURE 25 : FRONT TOWING AIR SUPPLY  
ACCESS PANEL QUICK CONNECT FITTINGS

**2.1.3 Drive Axle Flange Shaft Removal**

- 1. Apply the parking brake.
- 2. Remove the stud nuts and the washers (with Meritor drive axle) or cap screws (with ZF drive axle) from the flange shaft.

**NOTE: there is oil behind the flange shaft which comes out during disassembly**

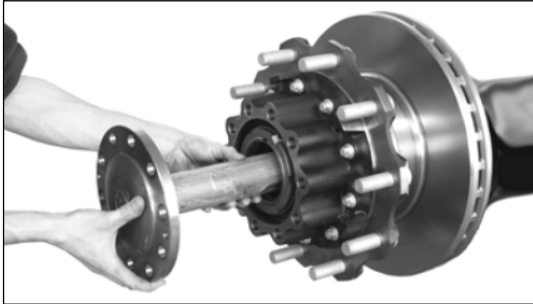

FIGURE 26 : ZF A-132 AXLE

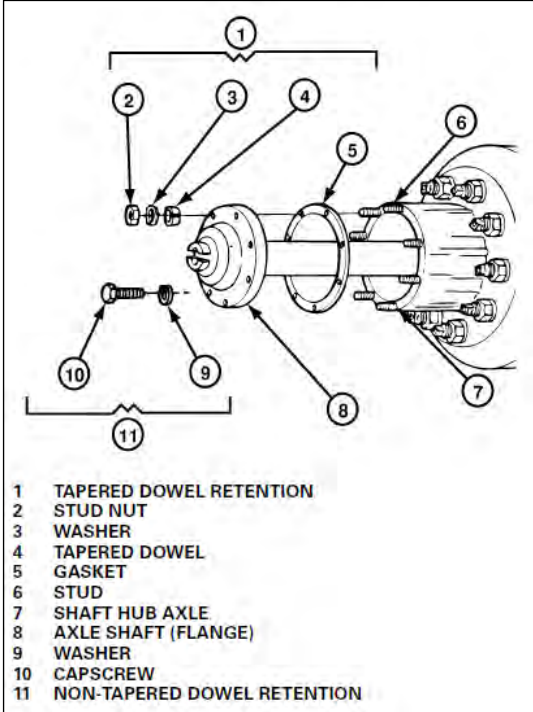



FIGURE 27: MERITOR RC23-165 AXLE

 **CAUTION**

Do not use a chisel or wedge to loosen the axle flange shaft and tapered dowels. Using a chisel or edge can result in damage to the axle shaft, the gasket and seal, and/or the axle hub.

3. Meritor axle: Loosen the tapered dowels in the flange of the axle shaft using the following methods.
  - a) Do not strike the round driving lugs on the flange of an axle shaft. Pieces can break off and cause serious personal injury. A 1.5-inch (38.1 mm) diameter brass hammer can be used as a drift.
  - b) Hold a 1.5-inch (38.1 mm) diameter brass drift against the center of the axle shaft flange, **inside the round driving lugs**.
  - c) Hit the end of the drift with a large hammer (5 to 6 lbs.‘) to loosen the axle shaft and tapered dowels from the hub.
4. Identify each axle shaft that is removed from the axle assembly so they can be installed in the same location after transporting or repair is completed. (Example: Match mark a mating axle shaft and hub).

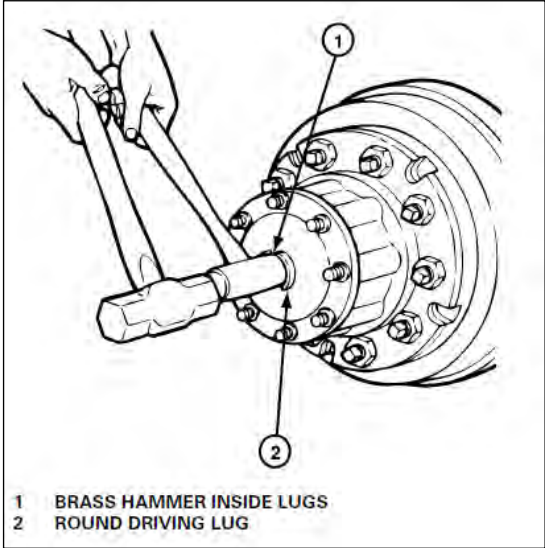

FIGURE 28: MERITOR RC23-165 AXLE

5. Remove the tapered dowels (if used), gasket or O-ring and the axle shaft from the axle assembly. Use a container to recover the oil.

6. Remove opposite flange shaft similarly.
7. Install a temporary cover over the open end of each hub where an axle shaft was removed. This will prevent dirt from entering the bearing cavity and loss of lubricant.

#### 2.1.4 After Towing

1. Remove the covers from the hubs.
2. Install the gasket or O-ring, and axle shaft into the axle housing and carrier in the same location it was removed from. The gasket and flange of the axle shaft must be flat against the hub. Rotate the axle shaft and/or the driveline as necessary to align the splines and the holes in the flange with the studs or holes in the hub.
3. **Meritor axle only:** Install the dowels over each stud and into the tapered holes of the flange.
4. Install the washers and stud nuts or cap screws.

<b>MERITOR RC23-165 AXLE</b>	<b>ZF A-132 AXLE</b>
Determine the size of the fasteners and tighten the nuts to the corresponding torque value shown below. <ul style="list-style-type: none"><li>• 9/16-18 plain nuts: <b>110 - 165 lbf-ft</b> (149-224 Nm)</li><li>• 5/8-18 plain nuts: <b>150 - 230 lbf-ft</b> (203-312 Nm)</li></ul>	Tightening torque M18x1.5 G10.9 screw <b>325 lbf-ft</b> (440 Nm)

5. Mount opposite flange shaft similarly.
6. Inspect the lubricant level in the axles and hubs where the axle shafts were removed. Add the correct type and amount of lubricant if necessary.

 <b>CAUTION</b>
Make sure axle shafts or driveshaft are installed correctly after towing. Tighten axle shaft and driveshaft nuts to the correct torque settings. Do not invert shafts.

## 2.2 TOWING FROM THE FRONT

The towed vehicle must be lifted from the front with front wheels off the ground. The tow truck must be equipped with the proper lifting equipment i.e. tow bar, axle forks and holders to reach under the **front axle** or the **front tow eye pads**. No other lifting points are recommended for towing.

Lifting and towing from any other point is not authorized as it may cause structural damage. **To prevent overloading the drive axle, do not unload or raise the tag axle when towing the vehicle.**

To prevent damage to the vehicle, use the **front tow eye pads** fixed to the vehicle chassis between the front axle and the front bumper. Only use a solid link tow bar and safety chains to tow the vehicle.

1. Block the wheels to prevent the vehicle from moving.
2. Perform the PREPARATION BEFORE TOWING. Refer to paragraph 2.1.
3. Disconnect both drive axle shafts to prevent damage to the transmission. Plug axle tubes to prevent oil loss. Refer to 2.1.3 DRIVE AXLE FLANGE SHAFT REMOVAL.



## CAUTION

The axle shafts must be disconnected to avoid serious damage to the Allison transmission. Lubrication is inadequate when towing.

To prevent damage to the drive train components, disconnect drive axle shafts before towing. Do not attempt to push or pull start a vehicle equipped with an automatic transmission.

**Failure to disconnect the propeller shaft, remove the drive axle shafts or lift the drive wheels off the ground before towing can cause serious transmission damage and void the warranty.**

### 2.2.1 First Lift

To allow lifting equipment fitted with axle forks to reach under the front axle or tow eyes, it is necessary to perform a first lift of the front of the vehicle using the tow eye pads as lifting points. This first lift will allow tow cans or blocks to be placed underneath front tires.

1. Retract the tow truck stinger arm.
2. On the first lift, position the tow bar fork holders under the front tow eye pads (Figure 30 and Figure 31) to lift the vehicle in order to place the front wheels firmly on the tow cans or blocks.

*Center to center measurement between tow eyes= 37 inches (Figure 29)*

**Note: No axle forks are needed for this first lift**



FIGURE 29

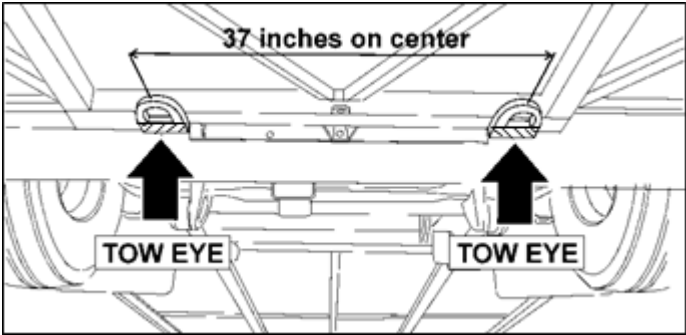

FIGURE 30



FIGURE 31: TOW EYE

- 3. Deploy the tow truck stinger arm, placing the axle fork holders under the tow eye pads (Figure 32).

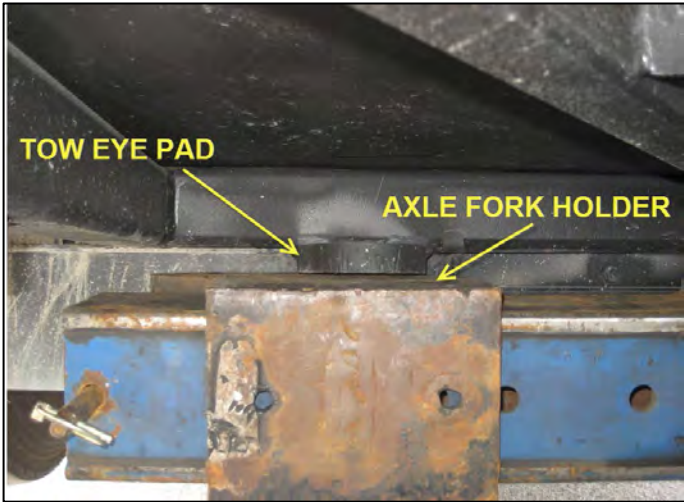

FIGURE 32

- 4. Lift the front end of the vehicle high enough to allow installation of tow cans or blocks. Place the tow cans or blocks perfectly centered underneath each front wheel (Figure 33).
- 5. With precaution, lower the front of the vehicle



FIGURE 33

**2.2.2 Second Lift- Front Tow Eye Pads as Lifting Point for Towing**

The tow eye pads are fixed to the vehicle chassis, fore of the front axle will be used as front end lifting points for towing.

1. Perform the first lift as instructed in paragraph 2.2.1 if not already done.
2. Place the axle forks on the tow bar fork holders (Figure 34).

**Use 3" to 4 ½" mouth axle forks preferably**



***Pre-adjust spacing between axle forks to = 37 inches***

3. Lower the tow bar and position under the front tow eye pads.
4. Adjust fork holder's position and hand guide the forks into each front tow eye. (Figure 35)
5. Lift the tow bar until the axle forks fit snugly into the front tow eyes (Figure 35).

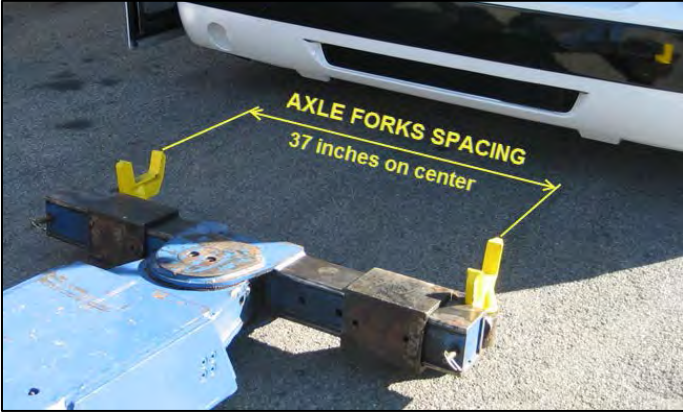

FIGURE 34

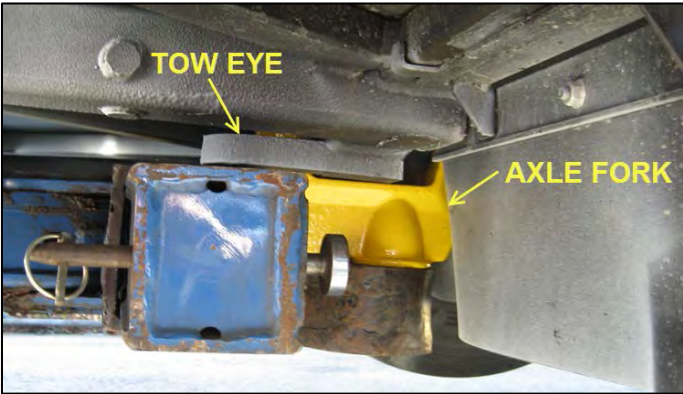

FIGURE 35

6. Raise the front of the vehicle.
7. Install a jack stand under the stinger arm for support and safety purposes and then lower the stinger arm so it rests on the jack stand (Figure 36). The tow cans or blocks can be removed from under the front axle wheels.



FIGURE 36

- 8. Tie the two choke chains together to secure the tow eyes to the tow bar attachment (Figure 38).



FIGURE 37

- 9. Attach the two tow truck safety chains from each of the two front lower radius rods (Figure 38) of the vehicle to the truck's tow eyes (Figure 38).



FIGURE 38

- 10. Confirm air is supplied to the vehicle. See 2.1 PREPARATION BEFORE TOWING



FIGURE 39

11. Raise the stinger arm and remove the support jack stand.
12. Lower the vehicle. The front tires should be 7" to 8" above the ground before the tow can proceed.
13. Use bungee cords to support the safety chains (Figure 40).



FIGURE 40

14. If required, use the appropriate jig to assure that the highest point on the vehicle **does not exceed** the maximum allowable height for towing (Figure 41).
15. Make sure the **parking brake** is released before moving the vehicle.
16. Observe safety precautions when towing.



FIGURE 41

*Avoid sharp turns where possible as safety chains may rub and damage the front bumper (Figure 42)*

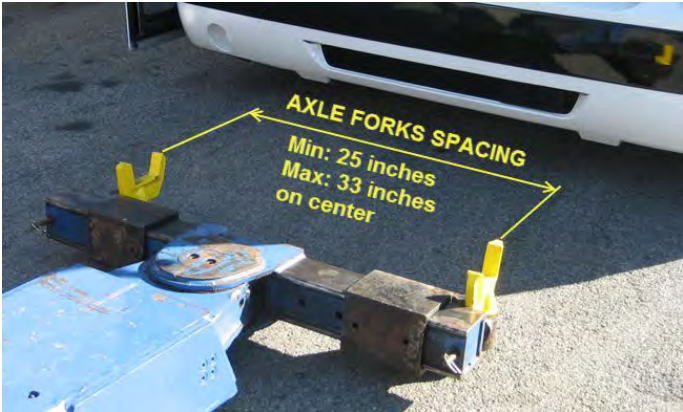

FIGURE 42

### 2.2.3 Second Lift- Using I-Beam Front Axle as Lifting Point for Towing

This method uses the I-beam axle as lifting points for towing (Figure8 and Figure9).

1. Perform the first lift as instructed in paragraph 2.2.1 if not already done.
2. Install regular axle forks onto tow bar fork holders.



**FIGURE 43**

***Pre-adjust spacing between axle forks***

Minimum spacing: 25 inches  
Maximum spacing: 33 inches

3. Lower the stinger arm to position the axle forks under the front axle hoisting points (Figure8 and Figure9).
4. Lift the tow bar until the axle forks grab the front axle I-beam at the hoisting points (Figure 44).
5. Raise the front of the vehicle.



**FIGURE 44**

6. Install a jack stand under the stinger arm for support and safety purposes and then lower the stinger arm so it rests on the jack stand (Figure 47). The



**FIGURE 45**

tow cans or blocks can be removed from under the front axle wheels.

7. Tie the two choke chains together to secure the front axle to the tow bar. Take up any slack that may remain and maintain proper tension on chains.



FIGURE 46

8. Attach the two tow truck safety chains from each of the two front tow eyes of the vehicle to the truck's tow eyes (Figure 47 and Figure 48).
9. Confirm air is supplied to the vehicle. See 2.1 PREPARATION BEFORE TOWING.



FIGURE 47

10. Raise the tow bar in order to remove the jack stand from under the stinger arm.
11. Lower the vehicle. The front tire should be about 7" to 8" above the ground before the tow can proceed.



FIGURE 48

12. Use bungee cords to support the safety chains (Figure 49).



FIGURE 49

13. Make sure that the **parking brake** is released before moving the vehicle.
14. Observe safety precautions when towing.



FIGURE 50

***Avoid sharp turns where possible as safety chains may rub and damage the front bumper (Figure 51)***



FIGURE 51



**CAUTION**

Make sure a safe distance is kept between the front of the vehicle and the tow truck. This space ensures that vehicle does not suffer damages when being towed.



**CAUTION**

Make sure axle shafts or driveshaft are installed correctly after towing. Tighten axle shaft and driveshaft nuts to the correct torque settings. Do not invert shafts.



**DANGER**

Do not carry passengers while the vehicle is being towed.

**2.3 X-SERIES RECOVERY USING OPTIONAL REAR TOW EYES**

Optional rear tow eyes allow recovery of a vehicle that is no longer on a drivable surface. Chains can be looped around or hooked to these rear tow eyes.



**CAUTION**

This recovery method should be used only for a short distance with all vehicle wheels on the ground

After the vehicle has been brought back on a drivable surface, it should be lifted and towed from the front, with front wheels off the ground.

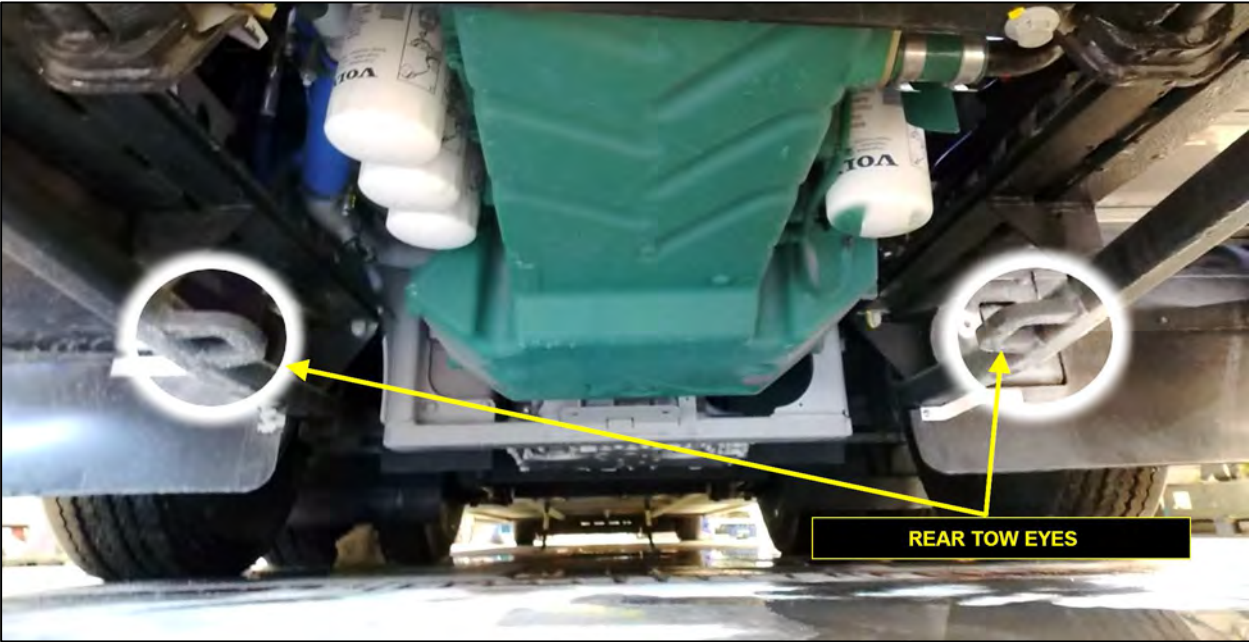

**FIGURE 52 : OPTIONAL REAR TOW EYES ON SIDE MEMBERS UNDER ENGINE CRADLE SUPPORT RAILS**

### 3. EMERGENCY TOWING

If the vehicle must be moved and standard towing procedures cannot be used, follow the alternate towing procedures below.

#### 3.1 REAR TOW USING NON-APPROVED LIFTING POINTS - EMERGENCY ONLY

 <b>CAUTION</b>
The vehicle should <b>NOT</b> be lifted and towed from the rear in normal situations.
In an emergency, however, it can be moved from the rear over a very short distance such as in a parking lot or to place the vehicle back on pavement.
Lifting the rear end from the engine cradle or from the side members located under the engine cradle support rails should be avoided. Doing so may cause structural damage (see image further in this document).

##### 3.1.1 PRECAUTIONS

In an emergency or if the vehicle has to be moved over a short distance, the side members may be used as lifting point. Try to lift from the strongest location along the side members which is near the rear sub-frame vertical member (Figure 53).

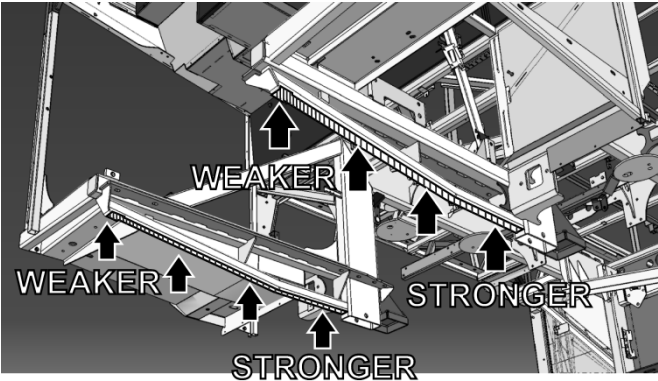

FIGURE 53: UNAPPROVED LIFTING POINTS FOR REAR END TOWING – SIDE MEMBERS LOCATED UNDER THE ENGINE CRADLE SUPPORT RAILS

Lift with precautions as the vehicle may sustain structural damage at the vertical structure shown on the image at right (Figure 54).

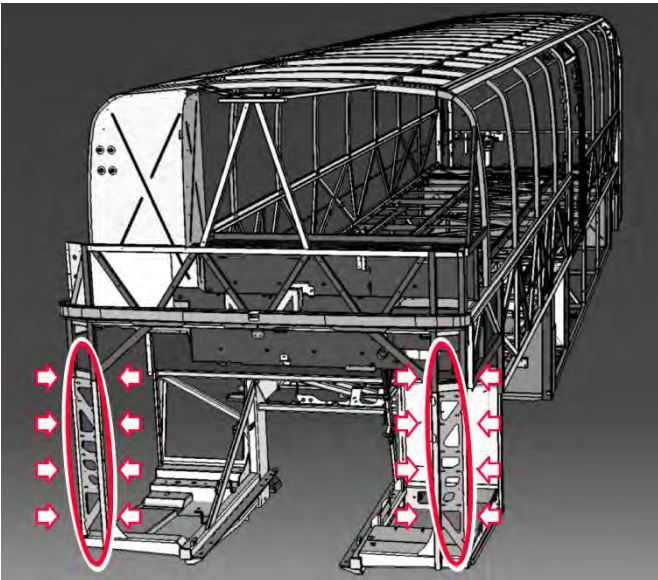

FIGURE 54: VEHICLE MAY SUSTAIN STRUCTURAL DAMAGE WHERE INDICATED WITH ARROWS DURING TOWING FROM THE REAR



**DANGER**

Do not carry passengers while the vehicle is being towed.

**3.1.2 FIRST LIFT**

A first lift of the vehicle is required. This first lift will allow tow cans or blocks to be placed underneath the drive axle tires.

1. Prepare the vehicle for towing as instructed in paragraphs 2.1 and 2.1.1
2. If not already done, chock the front wheels.
3. Retract the tow truck stinger arm (Figure 55).
4. Pre-adjust spacing between the axle fork holders. The spacing between the most distant edges of the fork holders should be **30 inches** (Figure 55).



FIGURE 55

**No axle forks will be used for this first lift**



TALL



REGULAR

5. Deploy the tow truck stinger arm. Place the fork holders under the engine cradle transverse beam as shown on Figure 56. Lift the tow bar until the fork holders come into contact with the cradle transverse beam.

	<b>CAUTION</b>
Use caution when lifting from the engine cradle transverse beam. Maintain the vehicle in that situation during the shortest period of time.	

**Lifting from the engine cradle is the least preferred option and should be done only if lifting from under the side members shown on Figure 53 cannot be achieved**



FIGURE 56



**CAUTION**

Remember, lifting the rear end from the side members located under the engine cradle or by the engine cradle itself may cause structural damage.

6. Raise the tag axle to prevent it from hanging unsupported.

7. On X-Series commuter vehicles only, the tag axle air valve lever is located in the front service compartment. Move it forward as shown on Figure 57.

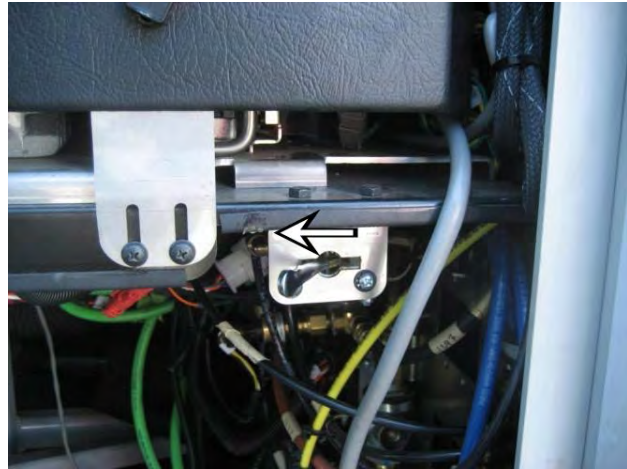

FIGURE 57: LOCATION OF COMMUTER TAG AXLE AIR VALVE

8. Lift the rear end of the vehicle high enough to allow installation of tow cans or blocks underneath the drive axle wheels (Figure 58).
9. With precautions, lower the rear of the vehicle.



FIGURE 58: TOW CAN

### 3.1.3 SECOND LIFT

1. Perform the first lift as instructed in paragraph 3.2 if not already done.
2. Retract the tow truck stinger arm.
3. Pre-adjust spacing between the axle fork holders to **43 inches**.

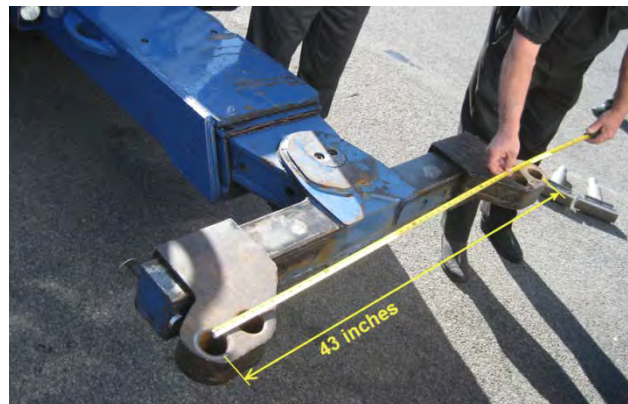
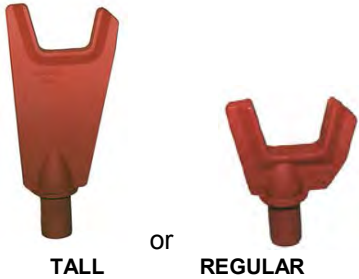

FIGURE 59

4. Install either long or short axle forks into fork holders.



- 5. Deploy the tow truck stinger arm. Place the axle forks under the rear tow eyes if equipped or under the side members (Figure 60).

Place the forks in a transversal position i.e. perpendicularly to the side members (Figure 61).

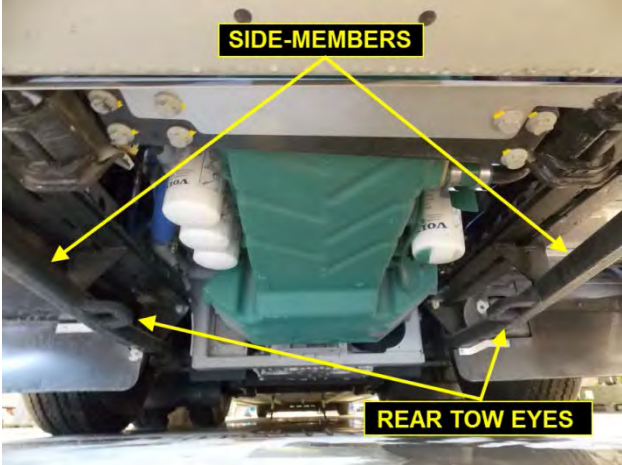

**FIGURE 60:** REAR TOW EYES ON SIDE MEMBERS LOCATED UNDER ENGINE CRADLE SUPPORT RAILS

- 6. Lift the tow bar until the axle forks grab the side members (Figure 61).

If equipped with rear tow eyes, lift the tow bar until the axle forks fit snugly into the side-members tow eyes.

***Avoid lifting at the side-members further toward the rear of the vehicle (close to the bumper)***



**FIGURE 61 :** PROPER LOCATION WHEN LIFTING THE SIDE MEMBERS

7. Place the fork's shorter finger outboard for better clearance (see Figure 62).



**FIGURE 62 : PROPER LOCATION WHEN LIFTING THE SIDE MEMBERS – VEHICLE EQUIPPED WITH REAR TOW EYES**

8. Raise the rear of the vehicle.
9. Install a jack stand under the stinger arm for support and safety purposes and then lower the stinger arm so it rests on the jack stand (Figure 63). The tow cans or blocks can be removed from under the drive axle wheels.

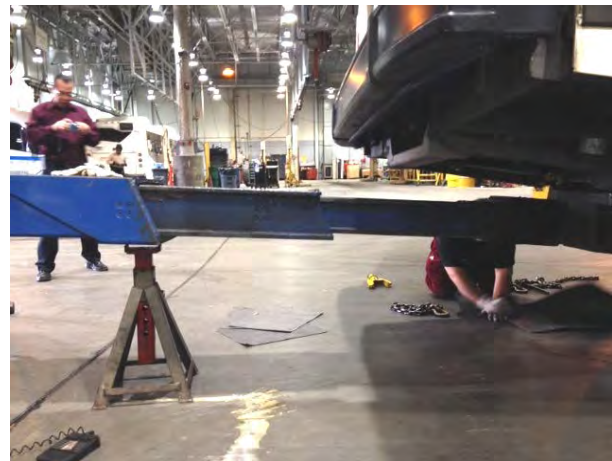

**FIGURE 63**

10. Install the choke chains. Tie the two choke chains together to secure the side members to the tow bar (Figure 64 and Figure 65). Take up any slack that may remain and maintain proper tension on chains.



FIGURE 64

11. Shorten the stinger arm to the safest minimum distance between the vehicle and the tow truck to allow the towed vehicle to be as close as possible to the truck yet allowing enough room for the vehicle to avoid collision with the tow truck during turns.

**Stinger to the rear bumper: Between 59" and 63"**



FIGURE 65

12. Attach the two tow truck safety chains from the vehicle engine cradle cross-member to the truck's tow eyes (Figure 66).
13. Raise the stinger arm and remove the support jack stand.
14. Lower the vehicle. The drive axle tires should be 5" to 6" above the ground before the short distance tow can proceed.



FIGURE 66

**3.2 VOLVO I-SHIFT TRANSMISSION TOWING MODE**

The procedure will activate “*tow mode*” on the transmission and will allow the vehicle to be towed flat on all wheels without having to remove the driveshaft.

	<b>CAUTION</b>
Check vehicle <b>VIN</b> before starting. Earlier vehicles do not have the proper software.	

**This special procedure applies to:**

Model	VIN
All X Series Vehicles Model Year : 2014 -	 <i>With I-shift gearbox</i> From 2PCG33497 <u>EC735459</u> up to Current Vehicles
All H Series Vehicles Model Year : 2013 -	 <i>With I-shift gearbox</i> From 2PCH33499 <u>DC712364</u> up to Current Vehicles

	<b>CAUTION</b>
<b>Forward towing only!</b> <u>Reverse towing (backing-up) is not allowed</u> with this procedure or damage to the gearbox will occur.	

	<b>CAUTION</b>
This procedure should be used in emergency only. This procedure does not have any visual indicator, therefore, make sure all steps of the procedure are fulfilled, or transmission damage may occur.	

Towing gear **3 HR** will be engaged if conditions below are fulfilled in the following sequence:

- A. Ignition key must be in the “**ON**” position
- B. Engine not running
- C. Adequate **air pressure to the gearbox/ Vehicle must have electrical power**
- D. Shift pad must be in **neutral**
- E. Vehicle must be towed **FORWARD** only

## PARTS / WASTE DISPOSAL

Discard according to applicable environmental regulations (Municipal/State[Prov.]/ Federal)

Access all our Service Bulletins on <http://techpub.prevostcar.com/en/>  
Or scan the QR-Code with your smart phone

**Are you a vehicle owner?**  
E-mail us at [technicalpublications\\_prev@volvo.com](mailto:technicalpublications_prev@volvo.com) and type "ADD" in the subject to  
receive warranty bulletins applicable to your vehicle(s) by e-mail.

