

June 21, 2018

Version 1

Emission Warranty Extension: MIL Is On With DTC P0420 or P0430 (All States Except CA, CT, ME, MA, NY, and VT)**AFFECTED VEHICLES**

Year	Model	Trim	VIN Range
2006-07	Accord Hybrid	ALL	Check the iN VIN status for eligibility

BACKGROUND

This bulletin will expire December 31, 2018.

In some cases, the ECM misinterprets sensor inputs as a warm-up three-way catalytic converter (TWC) deterioration and turns the MIL on with DTC P0420 or DTC P0430 (catalyst system efficiency below threshold) stored.

There are two bulletins to address the TWC deterioration with DTC P0420 or P0430:

- 18-022, Warranty Extension: MIL Is On with DTC P0420 or P0430 (All states Except CA, CT, ME, MA, NY, and VT), for vehicles currently registered in all states except CA, CT, ME, MA, NY, and VT. The warranty on these vehicles is extended 6 months from the launch of this campaign (**expires December 31, 2018**) or 200,000 miles, whichever comes first.
- 18-023, Warranty Extension: MIL Is On with DTC P0420 or P0430 (CA, CT, ME, MA, NY, and VT Only), for vehicles currently registered in CA, CT, ME, MA, NY, and VT. The warranty coverage is 17 years from the original date of purchase with **unlimited mileage for the first year of this warranty extension** based on the launch date of this extension. After one year, the coverage changes to 17 years from the original date of purchase or 200,000 miles, whichever comes first.

CUSTOMER NOTIFICATION

Owners of affected vehicles will be sent a notification of this campaign.

Do an iN VIN status inquiry to make sure the vehicle is shown as eligible.

CORRECTIVE ACTION

Do the inspection and if DTC P0420 or P0430 is stored, replace both the front and rear warm-up three-way catalytic converters, then update the PGM-FI software.

PARTS INFORMATION

Part Name	Part Number	Quantity
Warm-Up Three-Way Catalytic Converter (Front)	18190-RCJ-L00	1

CUSTOMER INFORMATION:The information in this bulletin is intended for use only by skilled technicians who have the proper tools, equipment, and training to correctly and safely maintain your vehicle. These procedures should not be attempted by "do-it-yourselfers," and you should not assume this bulletin applies to your vehicle, or that your vehicle has the condition described. To determine whether this information applies, contact an authorized Honda automobile dealer.

Part Name	Part Number	Quantity
Catalyst Cover B (Front)	18121-RCA-A00	1
Catalyst Cover A (Front)	18120-RCA-A00	1
Manifold Gasket (Front)	18115-RCA-A01	1
Manifold Gasket (Rear)	18115-RJA-G01	1
Self-Locking Nut (8 mm)	90212-RCA-A01	8
Warm-Up Three-Way Catalytic Converter (Rear)	18290-RCJ-L00	1
Catalyst Cover A (Rear)	18122-RCJ-A00	1
Catalyst Cover B (Rear)	18123-RCJ-A00	1
Flange Bolt (6 x 12 mm)	90023-PR7-A01	8
Self-Locking Nut (10 mm)	90212-SA5-003	9
Pre-Chamber Gasket	18393-SDB-A00	1
Exhaust Pipe Gasket	18212-SA7-003	2
Spindle Nut (24 mm)	90305-SD4-003	1
Set-Ring	44319-S84-300	1
Self-Locking Nut (12 mm)	90215-SB0-003	1
Castle Nut (12 mm)	90363-SDA-A03	1
Split Pin	94201-30220	1
Drain Plug Washer (20 mm)	94109-20000	1
Drain Plug Washer (20 mm)	90441-PK4-000	1
Washer Bolt (8 x 20 mm)	93404-08020-08	1
Washer Bolt (8 x 16 mm)	90004-RCA-A00	1
Flange Bolt (8 x 24 mm)	90165-S5B-003	3

REQUIRED MATERIALS

Material Name	Part Number	Quantity
Moly Paste	08734-0001	1 (1 tube will repair 10 vehicles)
Genuine Honda ATF-DW-1	08200-9008	4

SOFTWARE INFORMATION

NOTE

Unnecessary or incorrect repairs resulting from a failure to update the i-HDS or MVCI are not covered under warranty.

i-HDS Software Version: 1.004.031 **or later**

J2534 Software Information:

- PC Application Version: 1.1.0.2 **or later**
- Database update: 19-APR-2018 **or later**

Before beginning the repair, make sure that both the i-HDS and J2534 software are updated as listed above.

Do only the update listed in this service bulletin.

You cannot apply the updates with the MVCI as a standalone tool. To update the vehicle, you must use the MVCI or DST-i interface in conjunction with the J2534 Rewrite PC application on the i-HDS.

For more information about updating the iHDS, MVCI, or DST-i and vehicle systems, refer to Service Bulletin 01-026, *Updating Control Units/Modules*.

Trim	Software System	Program ID (or later)	Program P/N (or later)
ALL	PGM-FI	CJA690	37805-RCJ-A69

WARRANTY CLAIM INFORMATION

Operation Number	Description	Flat Rate Time	Defect Code	Symptom Code	Template ID	Failed Part Number
3111CB	Replace the front and rear warm-up three-way catalytic converter, then update the software.	2.9 hr	6C400	Q1R00	A18022A	18190-RCJ-L00

Skill Level: Repair Technician

INSPECTION

Connect the i-HDS and check for DTCs.

- If DTC P0420 or P0430 are stored, go to REPAIR PROCEDURE.
- **If DTC P0420 or P0430 are not stored, this bulletin does not apply.** Continue with normal troubleshooting.

REPAIR PROCEDURE

1. Remove the exhaust pipe A.

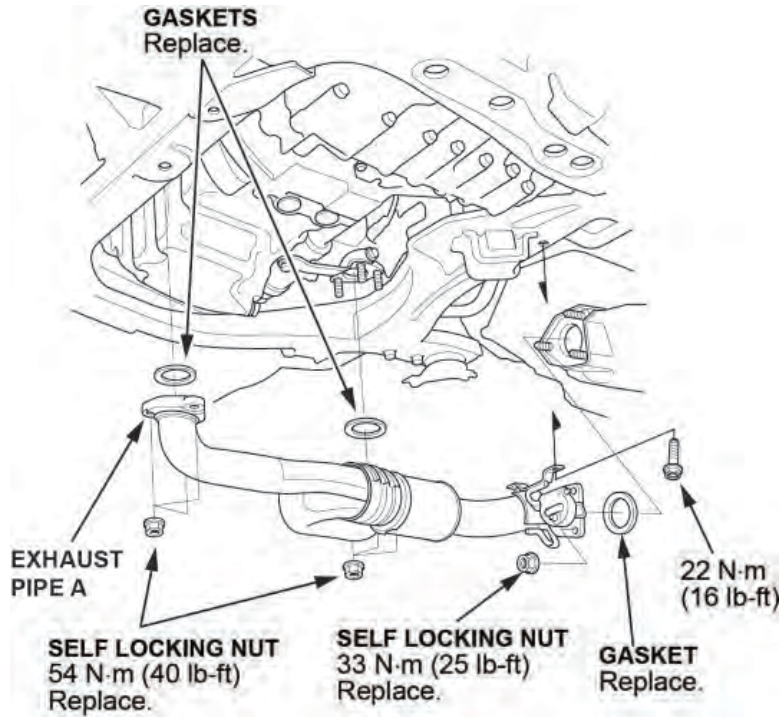

2. Remove front grille cover.

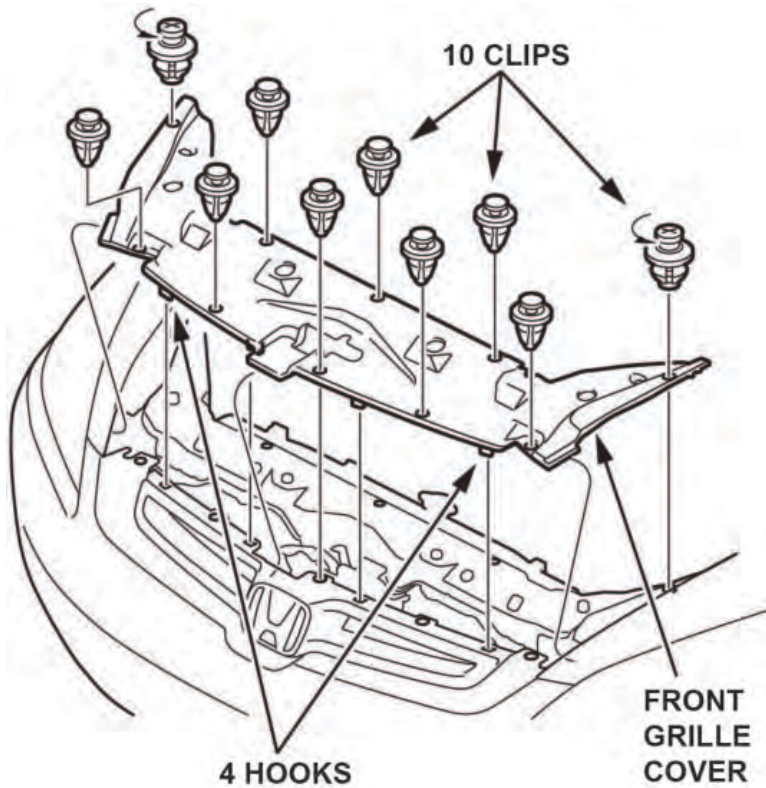

3. Remove the condenser fan shroud.

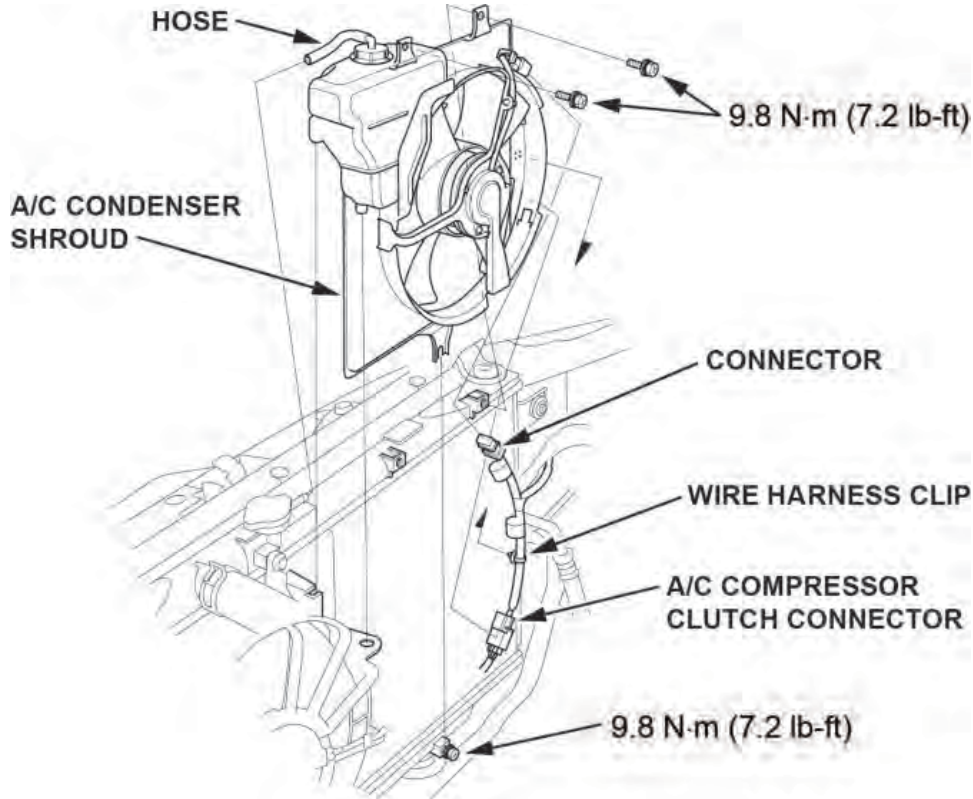

4. Loosen the front air fuel ratio (A/F) sensor connector and front secondary heated oxygen sensor (secondary HO2S) from the front warm up three-way catalytic converter (front catalytic converter), and disconnect the connectors.

NOTE

It is easier to loosen the A/F sensor and secondary HO2S sensor while the front catalytic converter is still attached to the vehicle.

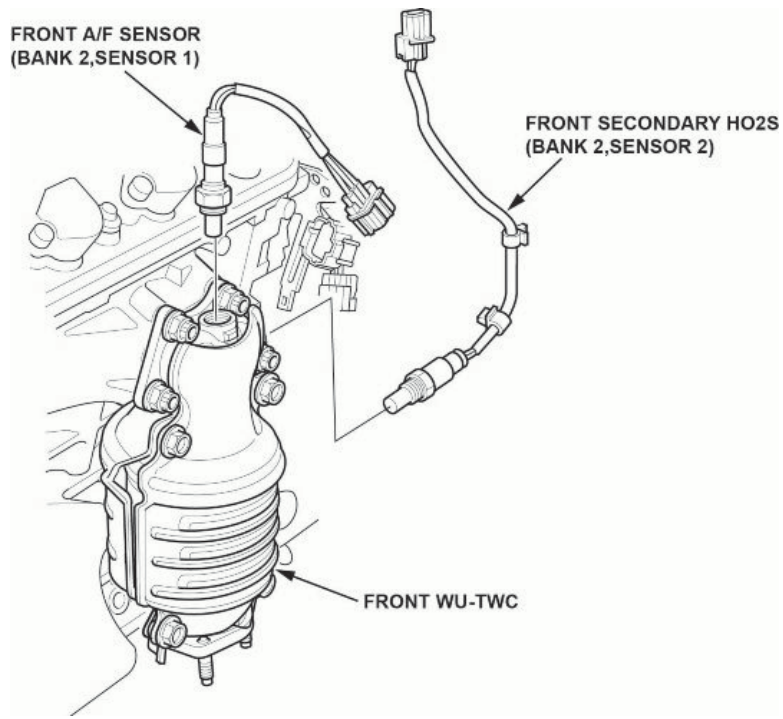

- Remove the front catalytic converter.

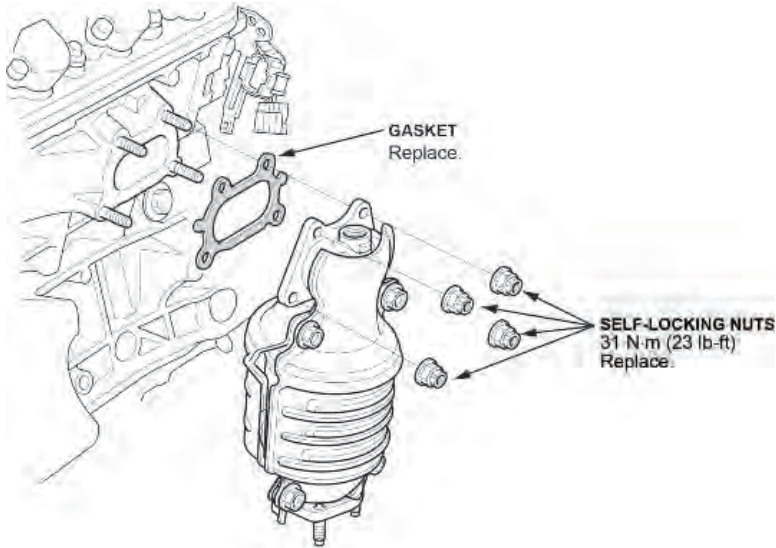

- Install the new covers on the new front catalytic converter, then transfer the original A/F sensor and secondary HO2S sensor onto the new front catalytic converter.

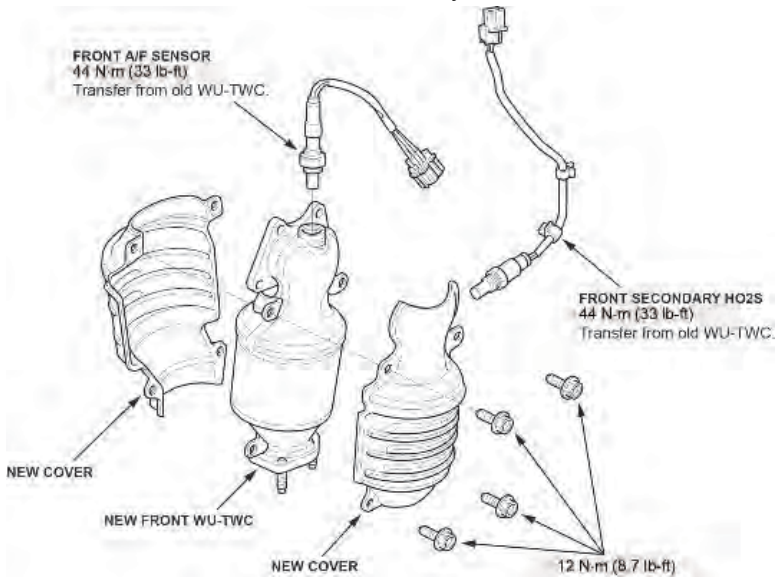

- Install the new front catalytic converter, fan shroud, and grill cover.
- Drain the transmission fluid.
- Remove the right-front wheel, the spindle nut, and the damper fork.

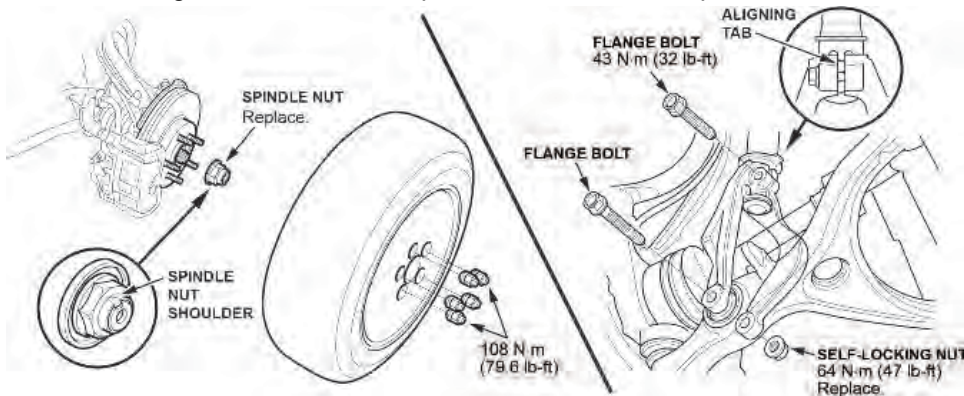

10. Remove the right driveshaft, and the intermediate shaft.

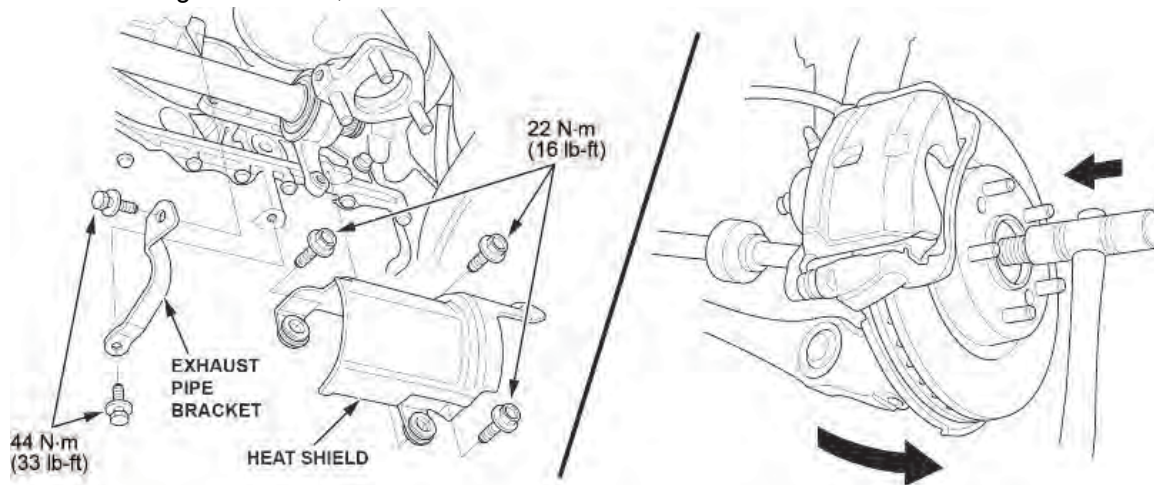

11. Loosen the front air fuel ratio (A/F) sensor connector and front secondary heated oxygen sensor (secondary HO2S) from the rear catalytic converter, and disconnect the connectors.

NOTE

It is easier to loosen the A/F sensor and secondary HO2S sensor while the rear catalytic converter is still attached to the vehicle.

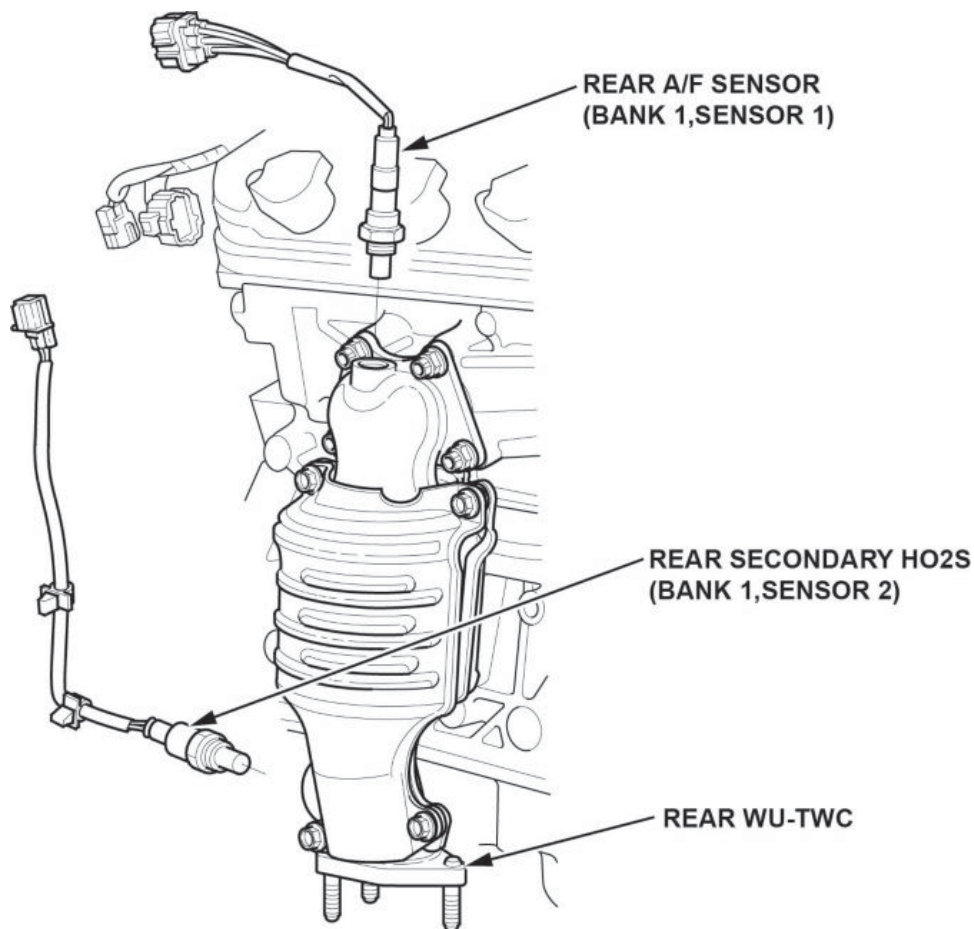

12. Remove the rear catalytic converter.

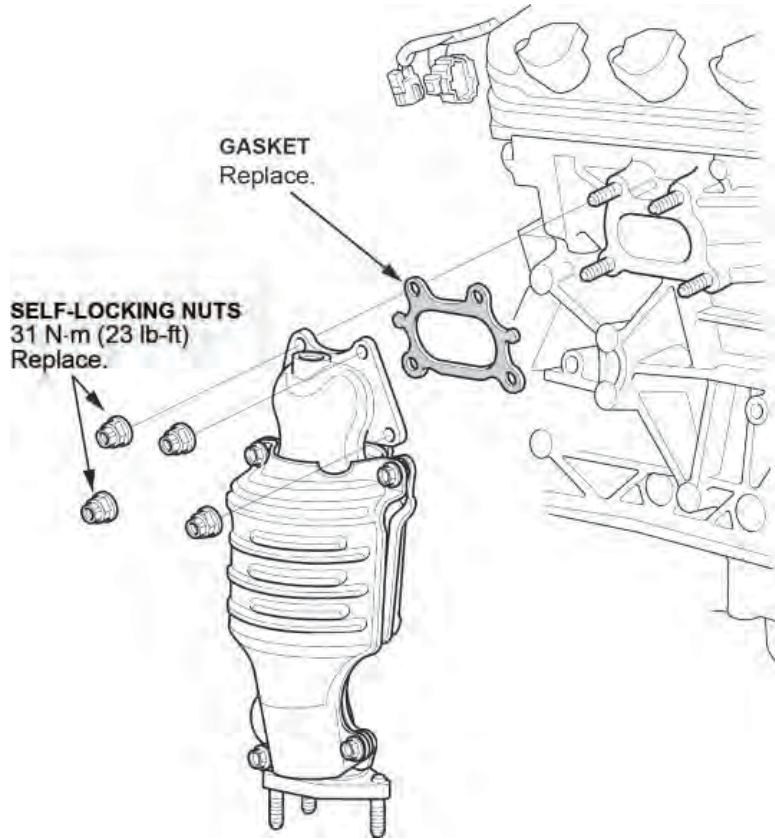

13. Install the new covers on the new rear catalytic converter, then transfer the original A/F sensor and secondary HO2S sensor onto the new rear catalytic converter.

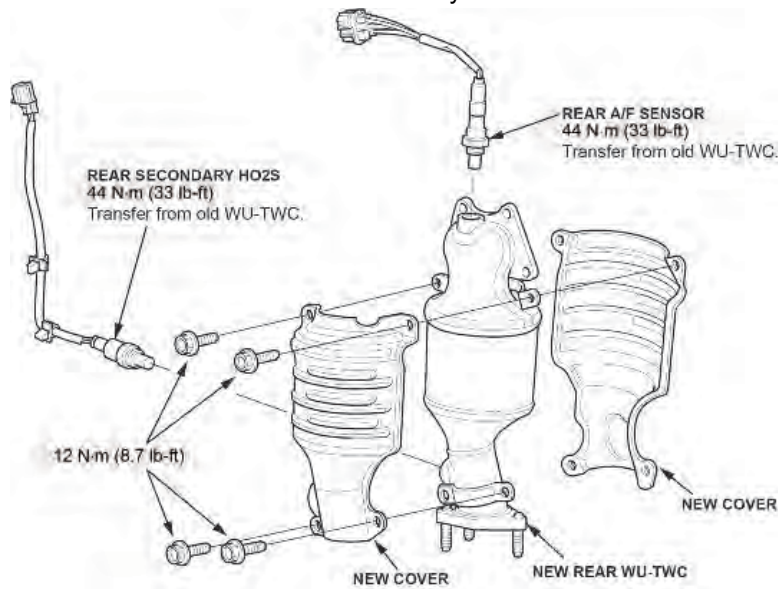

14. Install the new rear catalytic converter and the following components:

- Intermediate shaft
- Right drive shaft
- Damper fork
- Spindle nut
- A-pipe
- Right-front wheel

15. Refill the transmission.

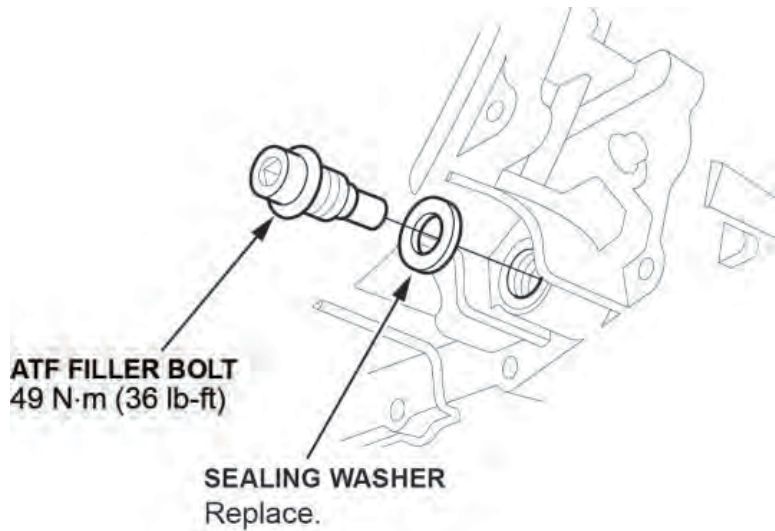

16. Update the PGM-FI software with the MVCI or DST-i interface in conjunction with the J2534 rewrite PC application on the i-HDS. Refer to Service Bulletin 01-023, *Updating Control Units/Modules*, and do the idle learn.

END