

May 11, 2018

09080 Version 6

Engine Oil Consumption Exceeds Client Expectations

Supersedes 18-009, dated May 2, 2018, to revise the information highlighted in yellow

AFFECTED VEHICLES

Year	Model	Trim	VIN range
2010–13	MDX	ALL	ALL
2011–12	RL	ALL	ALL
2009–14	TL SH-AWD	ALL	ALL
2010–13	ZDX	ALL	ALL

REVISION SUMMARY

Under INSTALLATION OF PISTONS, RODS, AND RINGS, step 4 was updated.

SYMPTOM

The oil control rings may become clogged with carbon deposits. These deposits restrict the ability to scrape and return oil from the cylinder walls to the crankcase, which can result in engine oil consumption that may exceed client expectations.

CORRECTIVE ACTION

If the client complains of oil consumption, do the oil consumption test. If the test shows excessive oil consumption, contact your DPSM for approval, then disassemble and inspect the engine. In most cases, you will need to replace the pistons, piston pins, rings and spark plugs.

REQUIRED MATERIALS

Part Name	Part Number	Quantity
Acura Long-Life Antifreeze/Coolant Type 2	OL999-9011	3
ATF Fluid	08200-9008A	4
Acura Genuine Motor Oil 5W-20	08798-9033	6
Power Steering Fluid (MDX/ZDX)	08206-9002	3

CLIENT INFORMATION: The information in this bulletin is intended for use only by skilled technicians who have the proper tools, equipment, and training to correctly and safely maintain your vehicle. These procedures should not be attempted by "do-it-yourselfers," and you should not assume this bulletin applies to your vehicle, or that your vehicle has the condition described. To determine whether this information applies, contact an authorized Acura automobile dealer.

TOOL INFORMATION

Part Name	Tool Number	Quantity
Tapered Piston Ring Compressor (90mm)	ARP 901-9000 (commercially available or equivalent)	1
Ridge Reamer (if needed)	WR30A (commercially available or equivalent)	1

PARTS INFORMATION FOR ALL MODELS

Part Name	Part Number	Quantity
Timing Belt	14400-RCA-A01	1
Flange Bolt (10 mm X 35 mm)	90163-SDA-A01	1
Oil Filter	15400-PLM-A01	1
EGR Pipe Gasket A	18716-R70-A01	1
EGR Pipe Gasket B	18719-R70-A01	1
Head Cover Gasket Set	12030-R70-A00	1
Head Cover Gasket Set RR	12050-R70-A00	1
Cylinder Head Gasket	12251-RKG-004	2
Exhaust Chamber Gasket	18115-R70-A01	2
Exhaust Pipe Gasket	18212-SA7-003	2
Front Injector Base Gasket	17055-RYE-A01	1
Front Water Passage Gasket	19411-P8A-A03	1
Intake Manifold Gasket	17105-RCJ-A01	1
Intake Manifold Cover Gasket (upper)	17146-R70-A01	1
Pre Chamber Gasket	18393-SDB-A00	1
Injector Base Gasket	17065-RYE-A01	1
Water Passage Gasket	19412-P8A-A02	1
Self-Lock Nut (10 mm)	90212-SA5-003	12
Self-Lock Nut (8 mm)	90212-RCA-A01	8
Oil Seal (41 mm X 56 mm X 7 mm)	91212-R70-A02	1
O-Ring	15221-RYE-A01	1
O-Ring (31.2 X 4.1)	91314-PH7-003	2
O-Ring (7.47 X 3.6)	91301-PLC-000	2
Bore Plate Seal	17112-RKB-003	1
Spark Plug	12290-R40-A02	6

PARTS INFORMATION ADDITIONAL (MDX)

Part Name	Part Number	Quantity
-----------	-------------	----------

Pre Chamber Gasket	18393-SJA-A01	1
Flange Bolt (10 mm X 30 mm) (Short Block Replacement Only)	90163-SDB-A00	3
Flange Bolt (10 mm X 35 mm) (Short Block Replacement Only)	90163-SDA-A01	1
Flange Bolt (10 mm X 20 mm) (Short Block Replacement Only)	90163-S5A-000	10
Flange Bolt (10 mm X 25 mm) (Short Block Replacement Only)	90113-S3V-A00	16
Flange Bolt (10 mm X 40 mm) (Short Block Replacement Only)	90164-SHJ-A00	2
Flange Bolt (12 mm X 115 mm) (Short Block Replacement Only)	90161-SZA-A00	1
Flange Bolt (12 mm X 20 mm) (Short Block Replacement Only)	95701-12020-08	1
Flange Bolt (12 mm X 65 mm) (Short Block Replacement Only)	95701-12065-08	2
Flange Bolt (12 mm X 83 mm) (Short Block Replacement Only)	90163-SHJ-A00	4
Spool Valve Filter Assembly (Short Block Replacement Only)	15825-P8A-A01	1
Oil Hole Gasket (Short Block Replacement Only)	15115-P8A-A01	1

PARTS INFORMATION ADDITIONAL (RL)

Part Name	Part Number	Quantity
Flange Nut (10 mm)	90310-TK5-A00	4
Hex Cap Nut (10 mm)	90310-SJA-000	8
Flange Bolt (10 mm X 35 mm) (Short Block Replacement Only)	90163-SDA-A01	1
Flange Bolt (10 mm X 30 mm) (Short Block Replacement Only)	90163-SDB-A00	3
Flange Bolt (10 mm X 30 mm) (Short Block Replacement Only)	90113-SJA-003	8
Flange Bolt (12 mm X 30 mm) (Short Block Replacement Only)	95701-12030-08	3
Flange Bolt (12 mm X 85 mm) (Short Block Replacement Only)	90167-SDA-A00	4
Flange Bolt (6 mm X 12 mm) (Short Block Replacement Only)	90003-RNA-A00	2
Flange Bolt (10 mm X 20 mm) (Short Block Replacement Only)	90163-S5A-000	8
Flange Bolt (10 mm X 60 mm) (Short Block Replacement Only)	90168-TA1-A00	2
Flange Bolt (12 mm X 45 mm) (Short Block Replacement Only)	90161-SDA-A01	1
Spool Valve Filter Assembly (Short Block Replacement Only)	15825-P8A-A01	1
Oil Hole Gasket (Short Block Replacement Only)	15115-P8A-A01	1

PARTS INFORMATION ADDITIONAL (TL)

Part Name	Part Number	Quantity
Hex Cap Nut (10 mm)	90310-SJA-000	1
Flange Bolt (10 mm X 35 mm) (Short Block Replacement Only)	90163-SDA-A01	1
Flange Bolt (10 mm X 30 mm) (Short Block Replacement Only)	90163-SDB-A00	3
Flange Bolt (10 mm X 25 mm) (Short Block Replacement Only)	90113-S3V-A00	8
Flange Bolt (12 mm X 30 mm) (Short Block Replacement Only)	90176-SKN-000	2
Flange Bolt (12 mm X 56 mm) (Short Block Replacement Only)	90170-TA1-A00	4
Flange Bolt (10 mm X 20 mm) (Short Block Replacement Only)	90163-S5A-000	8
Flange Bolt (10 mm X 60 mm) (Short Block Replacement Only)	90168-TA1-A00	2
Flange Bolt (12 mm X 45 mm) (Short Block Replacement Only)	90161-SDA-A01	1
Spool Valve Filter Assembly (Short Block Replacement Only)	15825-P8A-A01	1
Oil Hole Gasket (Short Block Replacement Only)	15115-P8A-A01	1

PARTS INFORMATION ADDITIONAL (ZDX)

Part Name	Part Number	Quantity
Pre Chamber Gasket	18393-SJA-A01	1
Flange Bolt (10 mm X 35 mm) (Short Block Replacement Only)	90163-SDA-A01	1
Flange Bolt (10 mm X 30 mm) (Short Block Replacement Only)	90163-SDB-A00	3
Flange Bolt (10 mm X 75 mm) (Short Block Replacement Only)	95701-10075-08	2
Flange Bolt (10 mm X 20 mm) (Short Block Replacement Only)	90163-S5A-000	10
Flange Bolt (10 mm X 25 mm) (Short Block Replacement Only)	90113-S3V-A00	16
Flange Bolt (10 mm X 40 mm) (Short Block Replacement Only)	90164-SHJ-A00	2
Flange Bolt (12 mm X 115 mm) (Short Block Replacement Only)	90161-SZA-A00	1
Flange Bolt (12 mm X 20 mm) (Short Block Replacement Only)	95701-12020-08	1
Flange Bolt (12 mm X 65 mm) (Short Block Replacement Only)	95701-12065-08	2
Flange Bolt (12 mm X 83 mm) (Short Block Replacement Only)	90163-SHJ-A00	4
Spool Valve Filter Assembly (Short Block Replacement Only)	15825-P8A-A01	1
Oil Hole Gasket (Short Block Replacement Only)	15115-P8A-A01	1

PARTS INFORMATION-CYLINDER HEADS

Part Name	Part Number	Quantity
Front Cylinder Head (MDX)	10004-RYE-A11	1
Rear Cylinder Head (MDX)	10005-RYE-A11	1
Front Cylinder Head (RL)	10004-RKG-A03	1
Rear Cylinder Head (RL)	10005-RKG-A03	1
Front Cylinder Head (TL)	10004-RK2-A02	1
Rear Cylinder Head (TL)	10005-RK2-A02	1
Front Cylinder Head (ZDX)	10004-RK2-A02	1
Rear Cylinder Head (ZDX)	10005-RK2-A02	1

PARTS INFORMATION-PISTONS/RINGS

Part Name	Part Number	Quantity
Piston Set	13010-RKG-305	6
Piston Ring Set	13011-RKG-305	6

PARTS INFORMATION-SHORT BLOCK

Part Name	Part Number	Quantity
Short Block (MDX)	10002-RYE-A11	1
Short Block (RL)	10002-RKG-A07	1
Short Block (TL)	10002-RK2-A04	1
Short Block (ZDX)	10002-RP6-A02	1

WARRANTY CLAIM INFORMATION

NOTE: There is no additional flat rate time for cylinder head replacement since this component is already disassembled.

The normal warranty applies.

Operation Number	Description	Flat Rate Time	Defect Code	Symptom Code	Template ID	Failed Part Number
1111EE	2010-13 MDX: Do the engine oil consumption test, and replace the pistons, rings, and spark plugs.	13.1 hrs	06901	09401	B18009A	10002-RYE-A10
A	If the front cylinder head was replaced - add		06901	09401	B18009B	
B	If the rear cylinder head was replaced - add		06901	09401	B18009C	
C	If both front and rear cylinder heads were replaced - add		06901	09401	B18009D	
1111EF	2010-13 MDX: Do the engine oil consumption test, and replace the short block.	13.6 hrs	06901	09401	B18009E	
A	If the front cylinder head was replaced - add		06901	09401	B18009F	

B	If the rear cylinder head was replaced - add		06901	09401	B18009G	
C	If both front and rear cylinder heads were replaced - add		06901	09401	B18009H	

1111EE	2009-14 TL: Do the engine oil consumption test, and replace the pistons, rings, and spark plugs.	11.0 hrs	06901	09401	B18009I	10002-RK2-A03
A	If the front cylinder head was replaced - add		06901	09401	B18009J	
B	If the rear cylinder head was replaced - add		06901	09401	B18009K	
C	If both front and rear cylinder heads were replaced - add		06901	09401	B18009L	
1111EF	2009-14 TL: Do the engine oil consumption test, and replace the short block.	11.0 hrs	06901	09401	B18009M	
A	If the front cylinder head was replaced - add		06901	09401	B18009N	
B	If the rear cylinder head was replaced - add		06901	09401	B18009O	
C	If both front and rear cylinder heads were replaced - add		06901	09401	B18009P	

1111EE	2011-12 RL: Do the engine oil consumption test, and replace the pistons, rings, and spark plugs.	10.4 hrs	06901	09401	B18009Q	10002-RKG-A06
A	If the front cylinder head was replaced - add		06901	09401	B18009R	
B	If the rear cylinder head was replaced - add		06901	09401	B18009S	
C	If both front and rear cylinder heads were replaced - add		06901	09401	B18009T	
1111EF	2010-13 RL: Do the engine oil consumption test, and replace the short block.	11.2 hrs	06901	09401	B18009U	
A	If the front cylinder head was replaced - add		06901	09401	B18009V	
B	If the rear cylinder head was replaced - add		06901	09401	B18009W	
C	If both front and rear cylinder heads were replaced - add		06901	09401	B18009X	

1111EE	2010-13 ZDX: Do the engine oil consumption test, and replace the pistons, rings, and spark plugs.	11.0 hrs	06901	09401	B28009A	10002-RP6-A01
A	If the front cylinder head was replaced - add		06901	09401	B28009B	
B	If the rear cylinder head was replaced - add		06901	09401	B28009C	
C	If both front and rear cylinder heads were replaced - add		06901	09401	B28009D	
1111EF	2010-13 ZDX: Do the engine oil consumption test, and replace the short block.	11.6 hrs	06901	09401	B28009E	
A	If the front cylinder head was replaced - add		06901	09401	B28009F	
B	If the rear cylinder head was replaced - add		06901	09401	B28009G	
C	If both front and rear cylinder heads were replaced - add		06901	09401	B28009H	

Skill Level: Repair Technician

DIAGNOSIS

1. Do an engine oil consumption test. Refer to job aid *Engine Oil Consumption Test*.
2. Review the results of the engine oil consumption test.
 - If the engine is consuming an unusually high amount of oil, contact your DPSM for approval, then go to REPAIR PROCEDURE.
 - If the engine is consuming a normal amount of engine oil, the vehicle is OK. Have the service advisor explain to the client that the vehicle is OK, and that the consumption of oil is within a normal range.

NOTE: Have the service advisor remind the client to check the engine oil level every time the fuel tank is filled. Modern engines require less frequent oil changes, which may impact the amount of oil used between oil changes.

REPAIR PROCEDURE

NOTE: The following service information procedures have been used in full or in part within this service bulletin. For more detail on these procedures and torque specifications for some components, refer to the service information.

- Engine Oil Replacement
- Battery Terminal Disconnection and Reconnection
- Fuel Pressure Relieving
- Coolant Replacement
- Drive Belt Removal/Installation
- Hydraulic Power Steering Fluid Check/Replacement
- Air Cleaner Removal/Installation
- Fuel Line/Quick-Connect Fitting Removal
- Front Bulkhead Cover Replacement
- Cylinder Head Cover Removal
- Intake Manifold Removal and Installation
- Warm Up TWC Removal/Installation
- Cylinder Head Removal and Installation
- Cam Chain Removal and Installation
- Valve Adjustment

- Propeller Shaft Removal
- Alternator Removal and Installation
- Ignition coil and Spark Plug Removal and Installation
- Exhaust Pipe and Muffler Replacement
- Strut Brace Removal/Installation

1. Relieve the fuel pressure.

NOTE:

- Use fender covers to avoid damaging painted surfaces.
- To avoid damaging any wires and terminals, unplug the circuit connectors carefully while holding the connector portion.
- Connect the i-HDS to the DLC, and monitor the ECT SENSOR 1. To avoid damaging the cylinder head, wait until the engine coolant temperature drops below 100°F (38°C) before loosening the cylinder head bolts.
- Mark all wiring and hoses to avoid misconnection. Also, be sure that they do not contact any other wiring or hoses or interfere with any other parts.

2. Wait until the engine is cool, then carefully remove the radiator cap.
3. Loosen the drain plug on the radiator, and drain the engine coolant.
4. Plug the power steering hoses at the reservoir, and move them out of the way.
5. Do the battery removal procedure.
6. Remove the engine cover. (TL has multiple covers.)

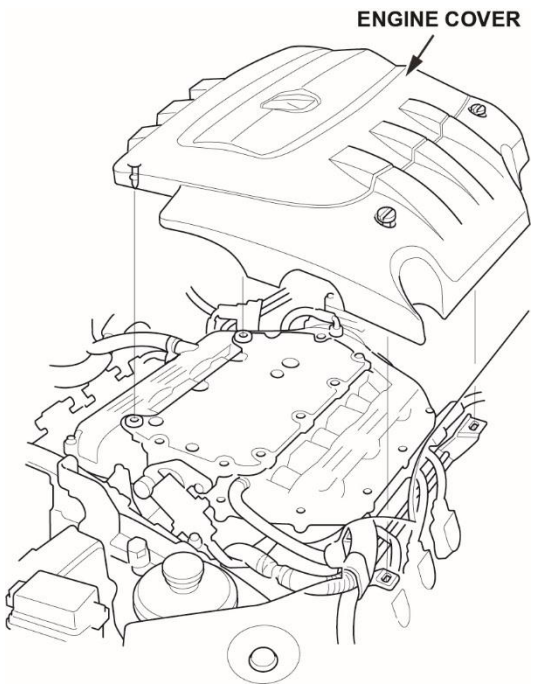

7. Disconnect the A/C suction line bracket at the right strut tower to allow for more clearance.
8. Remove the alternator.
9. Remove the intake manifold.
10. Remove the six ignition coils.
11. Remove the timing belt.

12. Disconnect the following engine wire harness connectors, and remove the wire harness clamps from the cylinder head:

- Six injector connectors
- Knock sensor connector
- ECT sensor 1 connector
- Engine mount control solenoid valve connector
- EGR valve connector
- CMP sensor connector
- Rocker arm oil control solenoid connector
- Rocker arm oil pressure switch connector
- Two A/F sensor connectors
- Two secondary HO2S connectors

13. Remove the front warm up TWC and the rear warm up TWC.

14. Remove the quick-connect fitting cover, then disconnect the fuel feed hose.

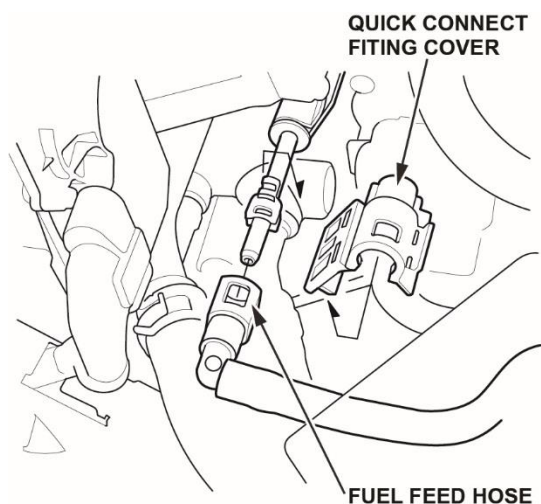

15. Remove the connector bracket from the front cylinder head.

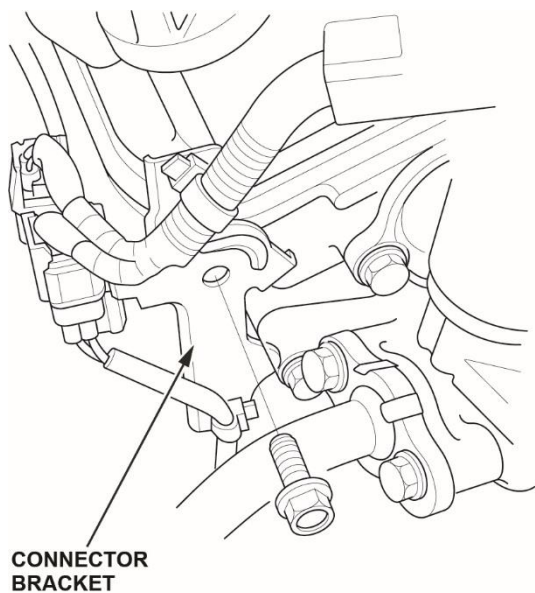

16. Remove the mount control solenoid valve bracket from the rear cylinder head.

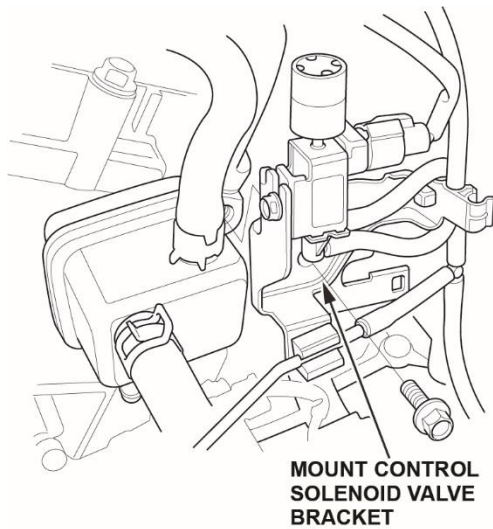

17. Remove the injector bases.
18. Remove the water passage.
19. Remove the camshaft pulleys and the back covers.

CYLINDER HEAD REMOVAL AND INSPECTION

1. Remove the cylinder head covers.
2. Remove the cylinder head bolts. To prevent warpage, loosen the bolts in sequence 1/3 turn at a time; repeat the sequence until all the bolts are loosened.

FRONT

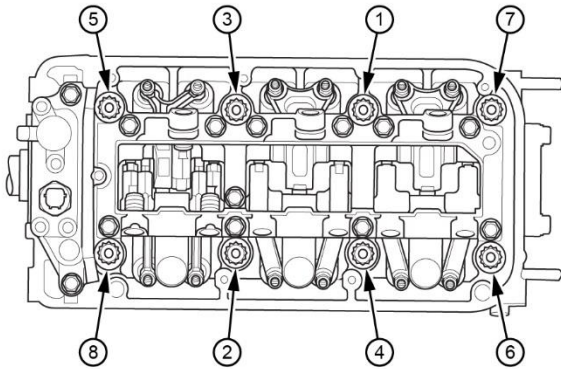

REAR

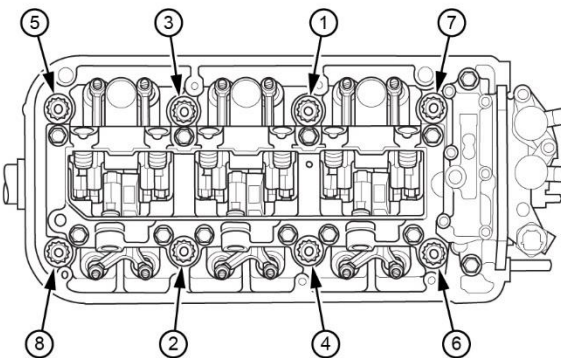

3. Remove the cylinder heads, and visually inspect the head of the valves on the combustion side of the cylinder head for damage.

NOTE: This is only a visual inspection looking for damage to the valves.

- If any of the valves show signs of damage, replace the affected cylinder head and go to CYLINDER BORE INSPECTION.
 - If the valves are ok, go to step 4.
4. Visually inspect each of the spark plugs for damaged or melted pieces of the center electrode or ground electrode.
 - If any of the spark plug shows signs of damage, remove the valve closest to the damaged plug from the cylinder head and go to step 5.
 - If the spark plugs are OK, go to CYLINDER BORE INSPECTION.
 5. Visually inspect the cylinder head valve seat and the valve seat face for damage.
 - If there are any signs of damage replace the cylinder head and go to CYLINDER BORE INSPECTION.
 - If the valves and valve seats are ok, assemble the cylinder head and go to CYLINDER BORE INSPECTION.

CYLINDER BORE INSPECTION

NOTE: IMPORTANT – When inspecting cylinder bores for blocks related to this service bulletin, keep in mind that blocks were produced with an aluminum cylinder sleeve. This sleeve will look characteristically different from most other engines that you have done service on. Additionally, just because a defect can be felt by a fingernail or pencil, it does not necessarily require the block to be changed.

Inspect the cylinder for any obvious concerns. Listed below are examples of concerns that may be found during your inspection, which have been proven by factory testing to not create a functional issue.

- During piston assembly at the factory, there may have been a vertical scratch created. This scratch can run the entire length of the cylinder bore and can be felt by a fingernail. Potentially, each bore could be effected; however, the cylinder block is OK. Go to OIL PAN REMOVAL.
- In some cases, there is a discoloration of the cylinder bore. Examples are shown below. The cylinder block is OK. Go to OIL PAN REMOVAL.
- Additionally, blocks that have an area of light bore scuffing, also shown below, have been confirmed by testing that the cylinder block is OK. Go to OIL PAN REMOVAL.
- If the concern that you observe is different from these examples, contact your DPSM for evaluation.

Example of ring install scratch



Examples of bore discoloration



Example of bore scuffing

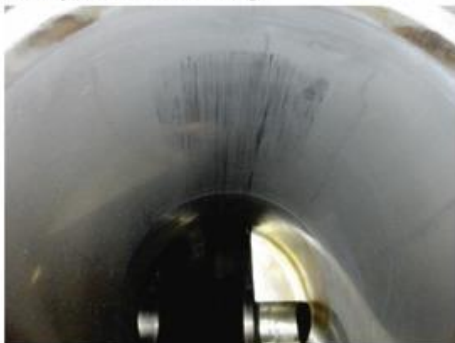

ENGINE OIL PAN REMOVAL

1. Drain the engine oil.
 2. Disconnect the secondary HO2S.
 3. Remove the under-floor TWC.
 4. Remove the rear warm up TWC bracket.
- NOTE: Do not remove the front and rear secondary HO2S sensor.

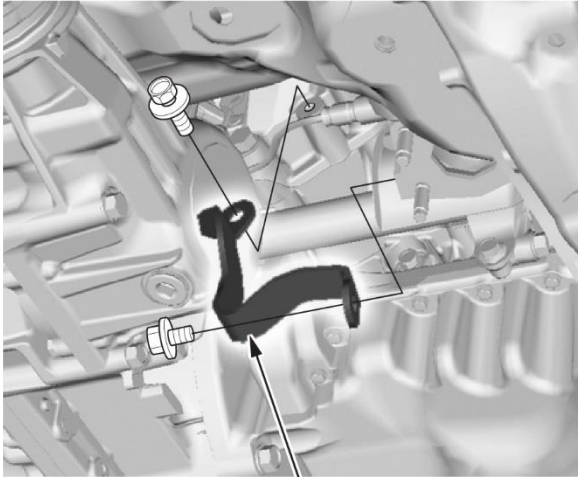

**REAR WARM UP
TWC BRACKET**

5. Disconnect the CKP sensor connector.
6. Remove the torque converter cover.
7. Remove the transmission assembly mounting bolts attached to the oil pan.

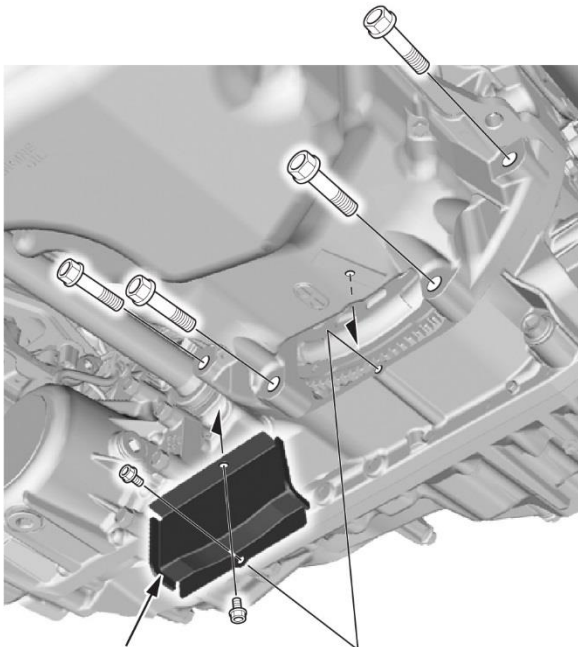

**TORQUE
CONVERTER
COVER**

8. Remove the bolts securing the oil pan.

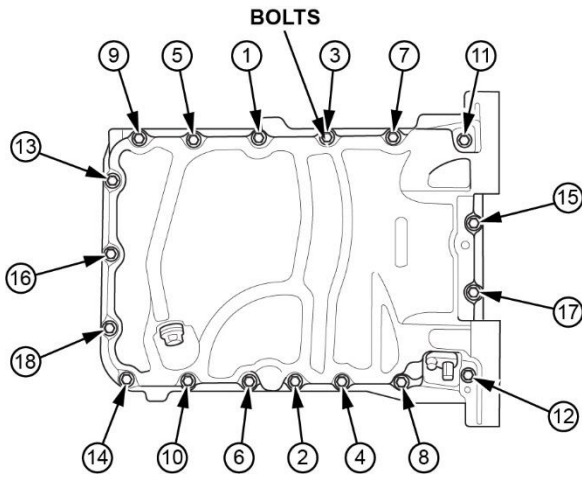

9. Using a flat blade screwdriver, separate the oil pan from the engine block as shown.

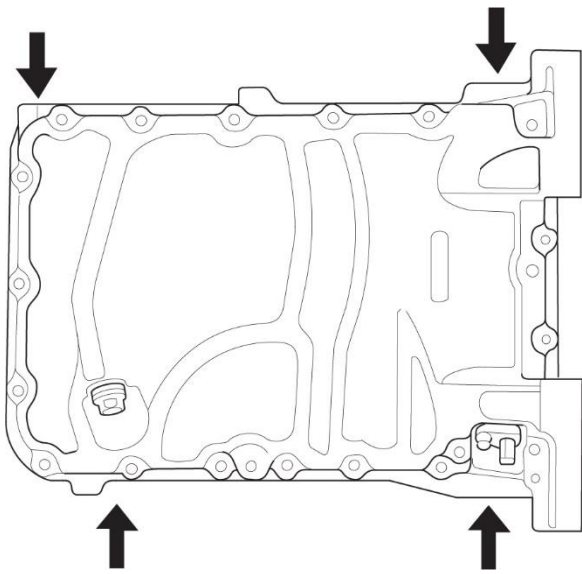

10. Remove the oil pan.

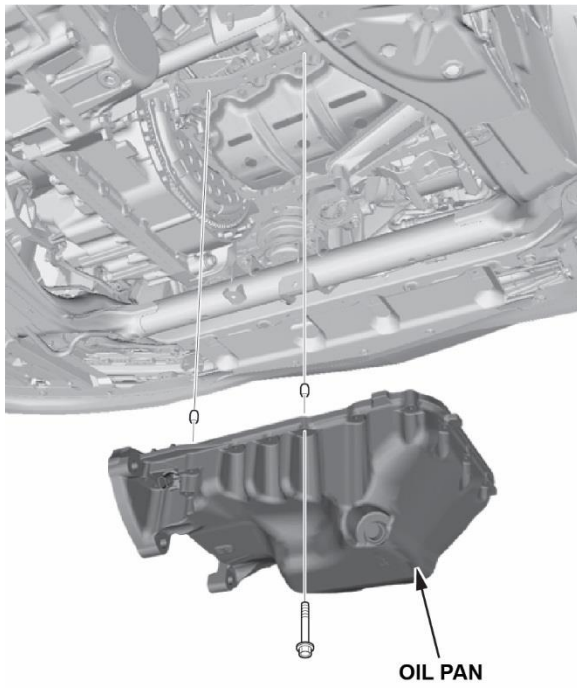

REMOVAL OF PISTON AND RODS

1. Remove the engine oil strainer and baffle plate.

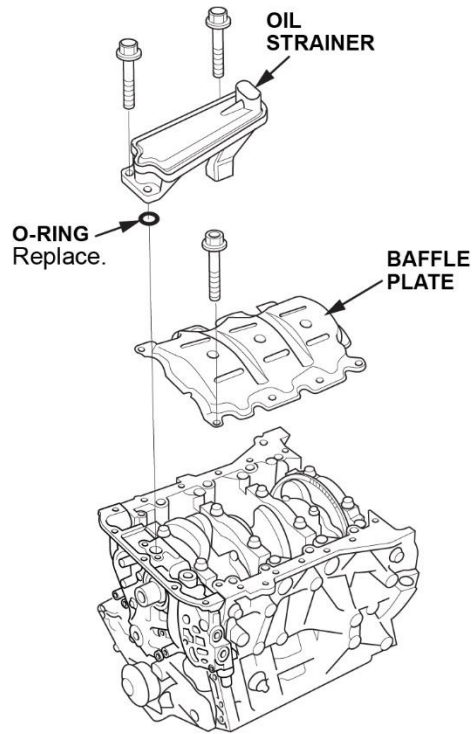

- If you can feel a ridge of metal or hard carbon around the top of each cylinder, remove it with a ridge reamer.

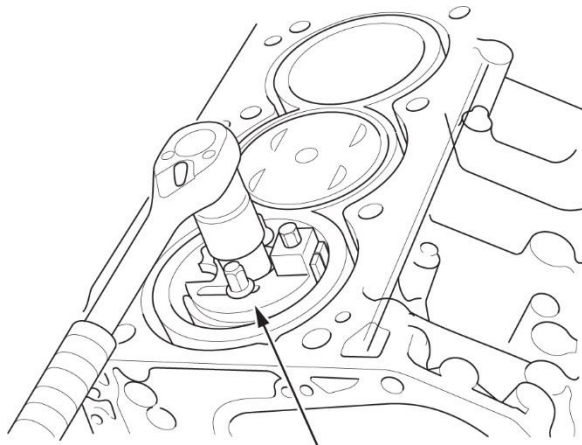

RIDGE REAMER

- Remove the connecting rod caps after setting the connecting rod journal at bottom dead center (BDC) for each cylinder. Remove the piston /connecting rod assembly by pushing on the connecting rod.

CORRECT

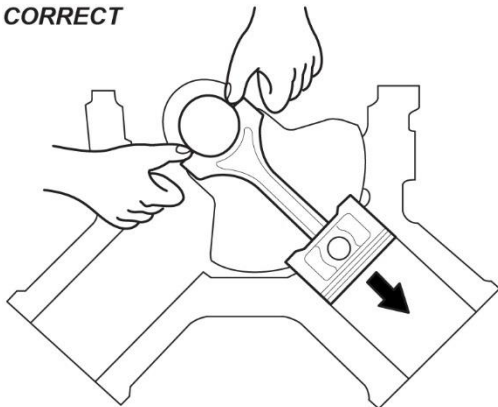

INCORRECT

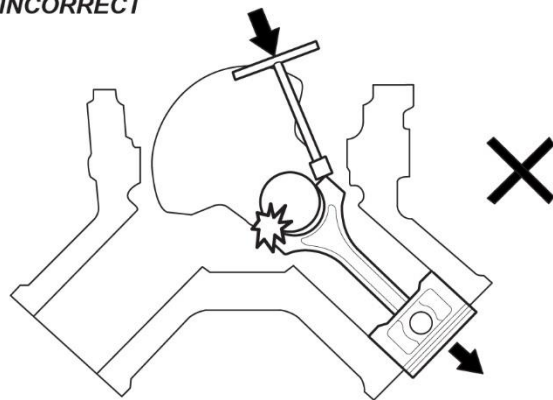

NOTE:

- Before removing the rod caps, use a grease pencil or suitable marking pen to mark each cap and its corresponding connecting rod with the cylinder number it came from. This ensures you are putting the same rod and cap back together with the right orientation.
- Take care not to damage the oil jets, the connecting rod journal, or the cylinder with the connecting rod.

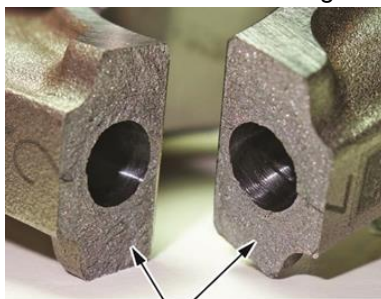

The uneven mating surfaces are uniquely matched and not interchangeable.

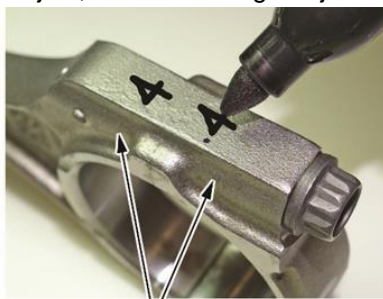

Mark the connecting rod and rod cap with the cylinder number.



These are manufacturing marks, and do not indicate the cylinder number.

- Do not confuse the existing markings on the side of the connecting rod and rod cap with a cylinder number. They're just manufacturing marks referring to the size of the big end of the rod.
- When torquing the rod cap bolts, refer to the service information for details.

If you would like to see a video on this subject, we have added one to *Tech2Tech*®. Look for "Tips When Working With Fracture Rods."

4. Remove the snap rings from both sides of each piston. Start at the cutout in the piston pin bore. Remove the snap rings carefully so they do not go flying or get lost. Wear eye protection.

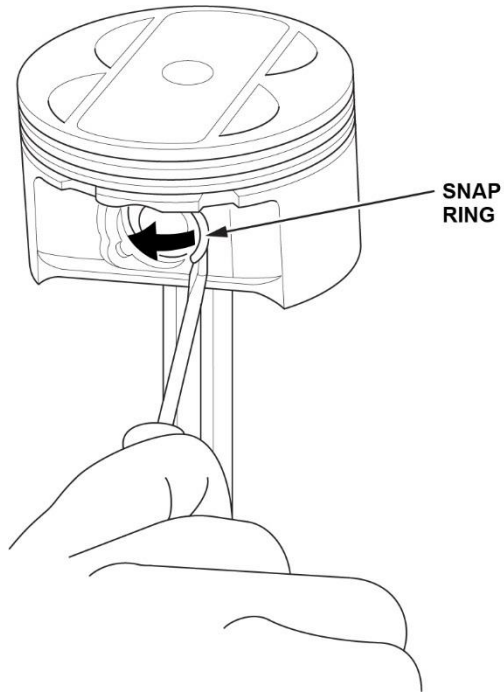

5. Separately heat each piston and connecting rod assembly to about 158 °F (70 °C), then remove the piston pin.

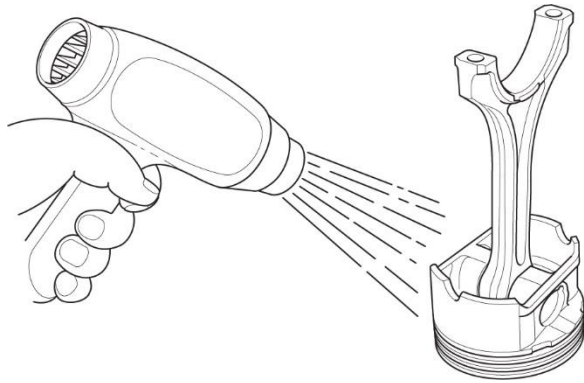

INSTALLATION OF PISTONS, RODS, AND RINGS

1. Install a piston pin snap ring only on one side of the new piston.

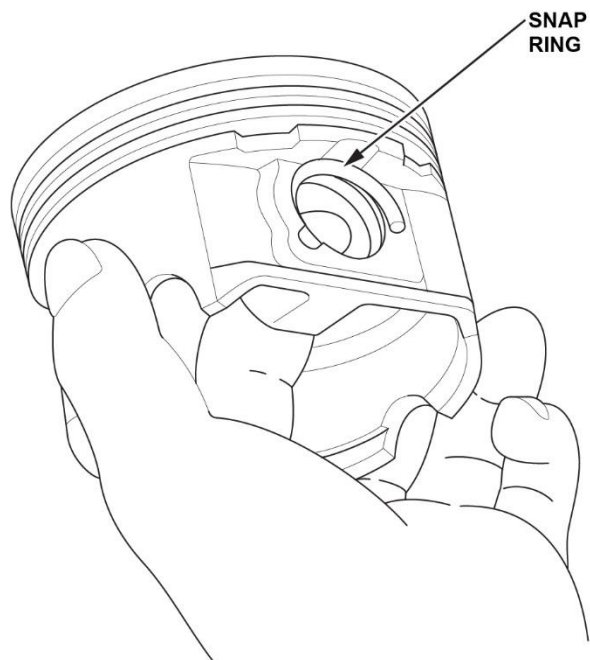

2. Coat the new piston pin bore in the piston, the bore in the connecting rod, and the piston pin with new engine oil.
3. Heat the new piston to about 158°F (70°C).

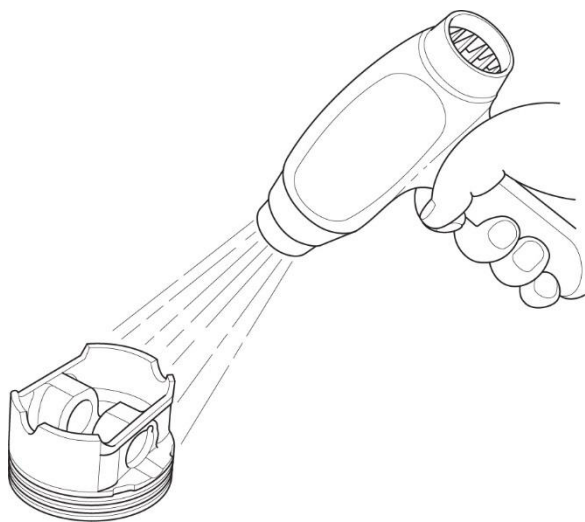

4. Assemble the new piston and the connecting rod with the embossed marks on the same side, as shown below. Install the new piston pin.

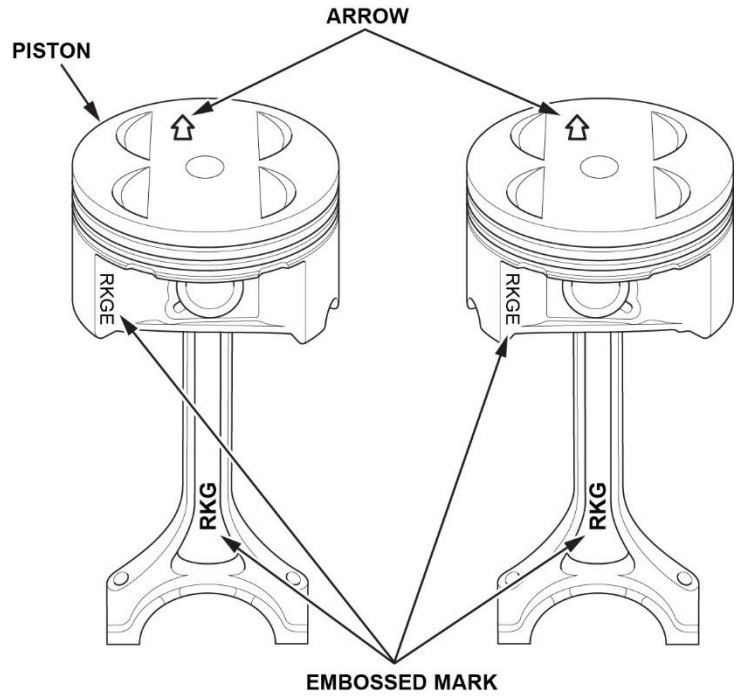
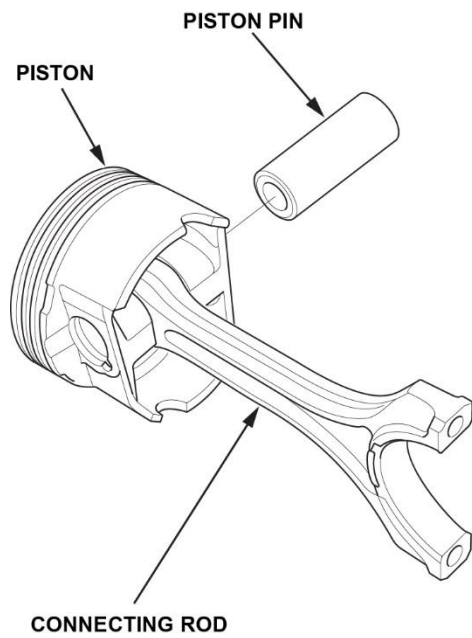

NOTE: Apply new engine oil to the new piston pin.

5. Install the remaining snap rings.
6. Assemble the other new pistons the same way.

7. Install the rings as shown. The top ring has a **1E** mark and the second ring has a **2E** mark. The manufacturing marks must be facing upward.

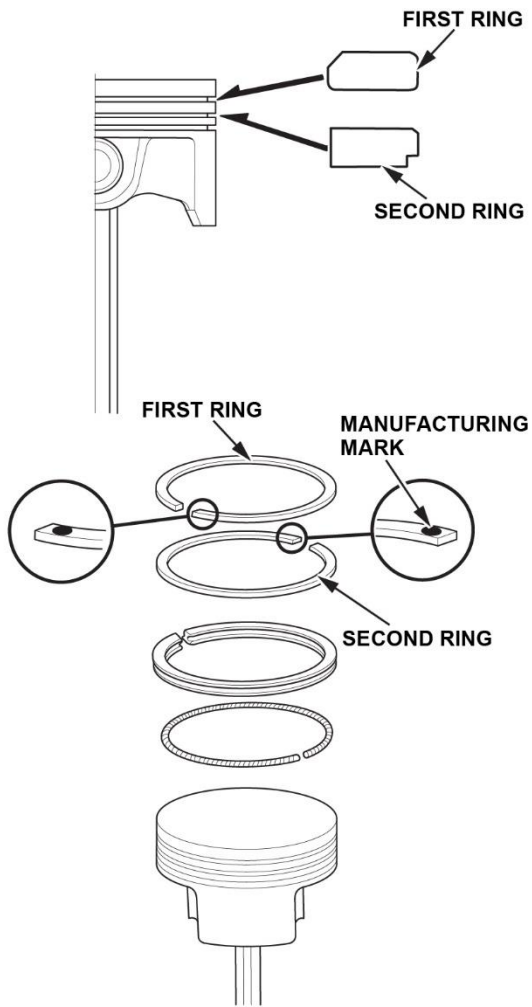

PISTON RING DIMENSIONS



Top Ring (Standard) A: 3.1 mm (0.122 in)

B: 1.2 mm (0.047 in)

Second Ring (Standard) A: 3.4 mm (0.134 in)

B: 1.2 mm (0.047 in)

8. Rotate the rings in their grooves to make sure they do not bind.
9. Position the ring end gaps as shown.

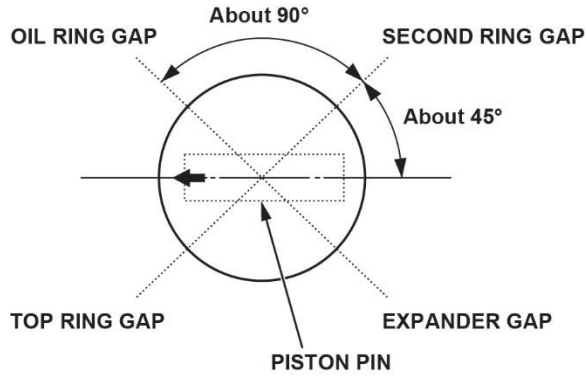

10. Position the piston/connecting rod assembly with the arrow facing the timing belt side of the engine block.

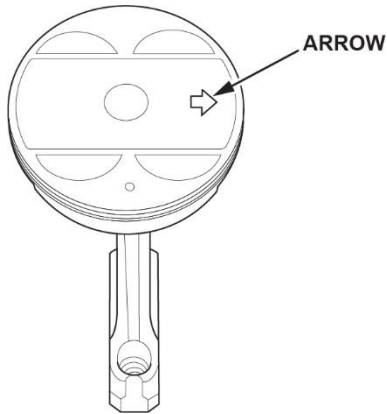

11. Set the piston in the ring compressor, and position it in the cylinder.

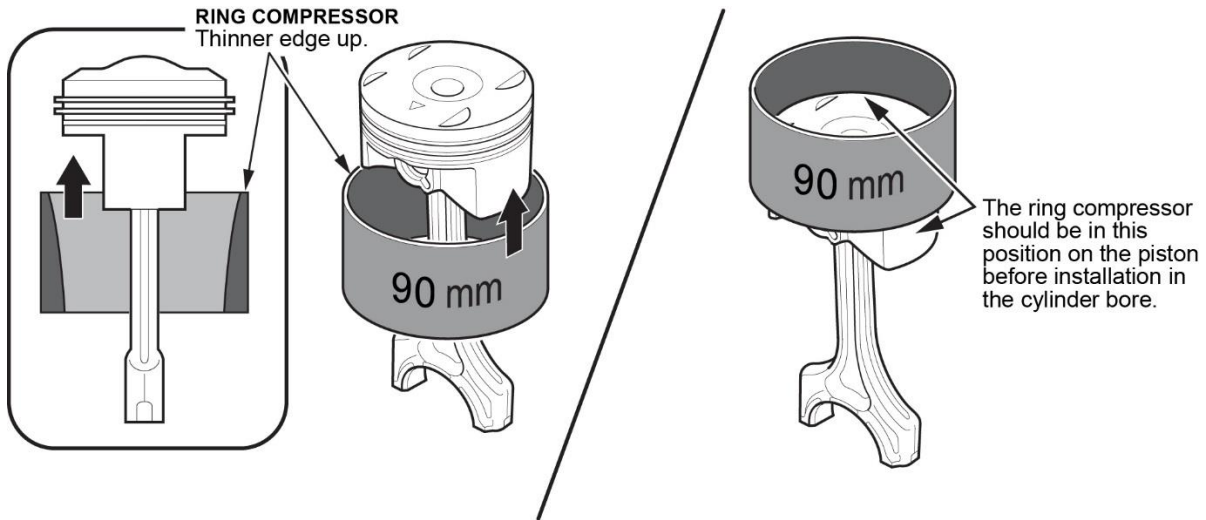

12. Set the ring compressor on the piston bore, then push the piston in with your hands.

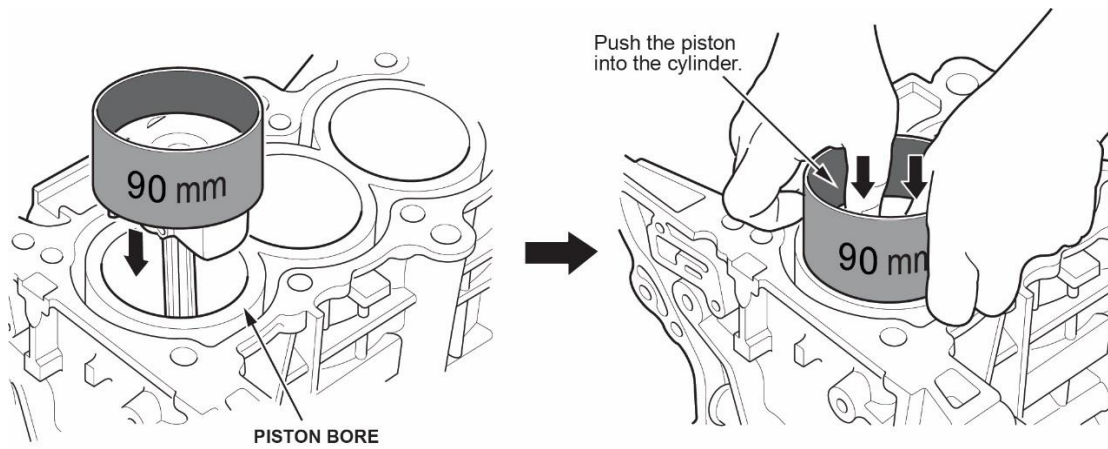

13. Stop after the ring compressor pops free, and check the connecting rod-to-rod journal alignment before pushing the piston into place.

14. Before installing the rod bolts, measure the diameter of each connecting rod bolt at point A and point B.

15. Calculate the difference in diameter between point A and point B.

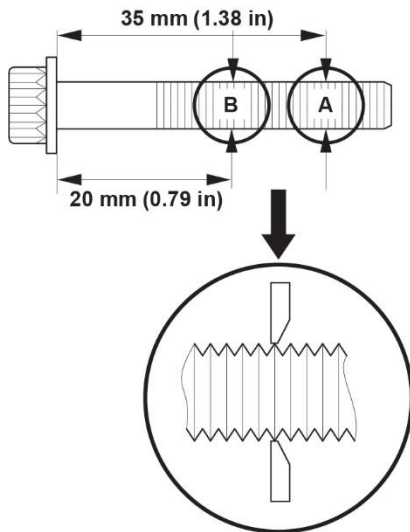

Point A-Point B = Difference in Diameter.

**Difference in Diameter Specification:
0-0.1 mm (0-0.004 in)**

16. If the difference in diameter is out of tolerance, replace the connecting rod bolt.
17. Install the connecting rod bearing, then line up the mark on the connecting rod and the rod cap.

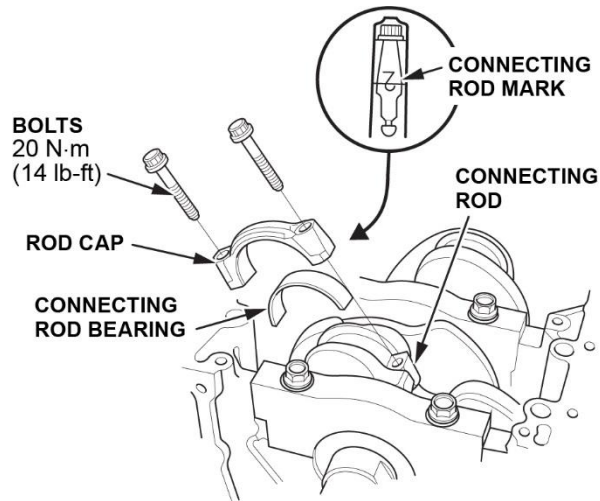

18. Apply new engine oil to the bolt threads and flanges. Torque the bolts to **20 N·m (15 lb-ft)**.
19. Tighten the connecting rod bolt an additional **90°**.

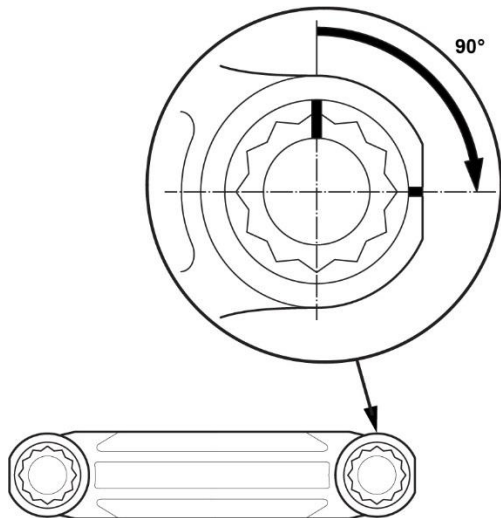

NOTE: Remove the connecting rod bolt if you tightened it beyond the specified angle, and inspect the connecting rod bolt. Do not loosen it back to the specified angle.

20. Install the engine oil strainer and baffle plate.

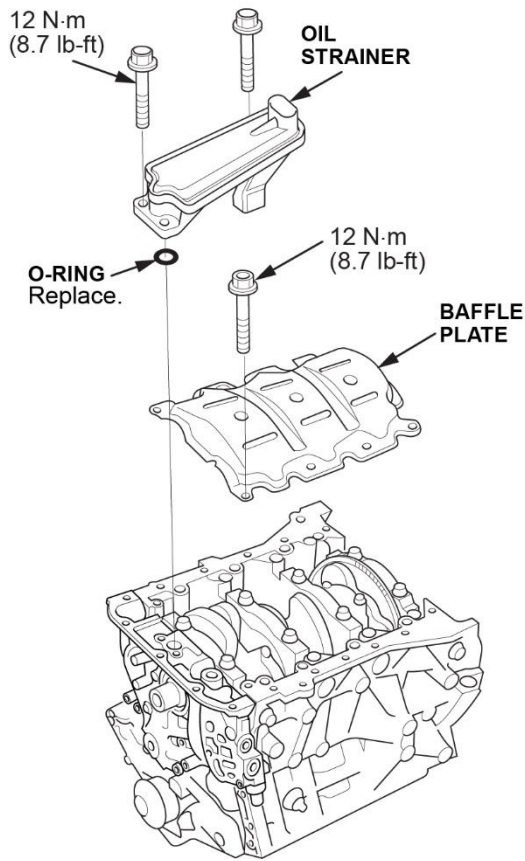

21. Install all removed parts according to the service information.

SHORT BLOCK REPLACEMENT

NOTE: When you replace the short block, do not replace the pistons or rings; the new block already has the counter-measured pistons and rings installed.

1. With the vehicle lowered on the rack, remove/disconnect any remaining hoses, connectors, and components, including the oil filter base/oil filter assembly, so you can remove the short block with an engine hoist.

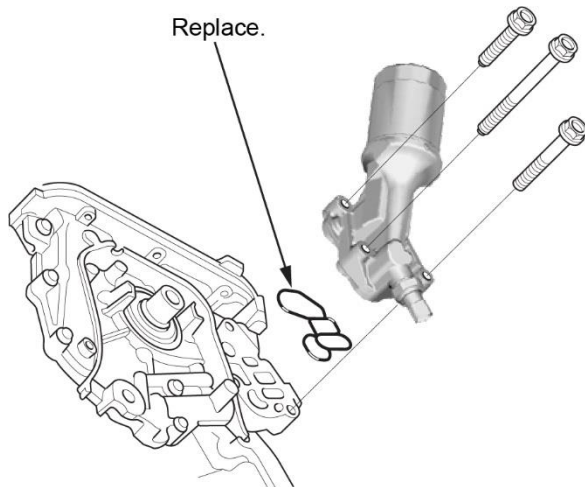

2. Raise the vehicle.
3. Remove the lower transmission housing bolts, the drive plate bolts, axle bearing support, and any other brackets and bolts that secure the transmission to the short block.

4. Lower the vehicle, loosen the remaining trans/block bolts, and remove the front and rear engine mount bolts. Support the transmission with a floor jack and rubber block under the transmission bell housing area. Set up an engine hoist with a sling to remove the short block up and out of the engine compartment.

NOTE: You will not completely remove the block/trans bolts until the engine is secured with the hoist.

5. Remove the upper transmission housing bolts and two of the front engine/transmission mount bolts, then begin to separate the short block from the transmission.

6. Lift the short block assembly from the vehicle, and place the assembly on a work bench or other suitable surface.

NOTE: The rear engine mount bracket can remain bolted to the block while it is being lifted out. As the block is lifted it might need to rotate approximately 90 degrees so the bracket can clear the front and rear cowl. This rear bracket can be transferred to the new block before hoisting it back in. MDX is unable to be lifted with the rear mount attached to the engine. This will have to be removed prior to lifting the engine out.



7. Transfer all remaining components from the original block to the new block and then carefully hoist the new short block assembly into the vehicle.

NOTE: Installation of the short block with the cylinder heads attached to the short block will not allow for proper clearance. The cylinder heads must be installed after the short block is installed in the engine compartment. Make sure all bolt holes are clean before installing the short block.



8. Install all removed parts according to the service information, and refill all fluids.

END