

REFERENCE:	Nova Bus Manuals
SECTION:	12: Interior Furnishing
RS N°:	MQR 7621-1007
EFFECTIVE IN PROD.:	N/A

APPLICATION DEADLINE:N/A

SUBJECT:	Articulation stanchion
JUSTIFICATION:	New improved stanchion is now available for installation in the articulation section of the vehicle.

LEVEL	DESCRIPTION	DIRECT CHARGES		TIME
		LABOUR	MATERIAL	
1	Installation of new stanchion	Client	Client	–
2	–	–	–	–

MATERIAL

QTY	PART N°	REV.	DESCRIPTION	REPLACES PART N°
LEVEL 1				
1*	N90327-25	–	STANCHION ARTIC ASSY SS	N48035-01
4*	N11169	–	BOLT M8X20 YP GR8.8 DIN933	–
4*	N21101	–	WASHER M8 OVERSIZE YP DIN9021	–
2*	N40770	–	BLOCK TENON M8	–
LEVEL 2				
–	–	–	–	–

* The material of this LI is to replace a single stanchion. If you are replacing the stanchions on both sides, please order this LI twice per vehicle.

To order, please contact Prevest Parts by phone at 1-800-771-6682, by fax at 1-888-668-2555 or by email at prevostparts.commandes@volvo.com. Specify document number, quantity of parts required and shipping address.

DISPOSAL OF PARTS

REMOVED PARTS ARE:	DISCARDED *	RETAINED	* Dispose of the unused parts and the defective parts in accordance with local environmental standards in effect.
	Yes	–	

REVISION HISTORY

REV.	DATE	CHANGE DESCRIPTION	WRITTEN BY
NR	2018JA30	Initial release	Kumaraswamy K S
R1	2018MR29	Page 1: Quantity of material adjusted to replace one side at a time. Note added for the customer to specify if he wants to order 1 or 2 stanchions.	André Pelletier
R2	2018AL04	Stanchion color is SS in material list	André Pelletier

CLIENT	ORDER	ROAD NUMBER		VIN (2NVY/4RKY...)		QTY
		FROM	TO	FROM	TO	
Austin - CMTA - Texas	L636	5002	5022	S92U1D4500306	S92U0D4500328	21
Austin - CMTA - Texas	LA17	5101	5107	S92J2H9775763	S92J3H9775769	7
CT Transit - Connecticut	L554	1041	1065	S92U1A4000139	S92U0A4000164	25
CT Transit - Connecticut	L571	1101	1110	S92YXB4000144	S92Y4B4000169	10
CT Transit - Connecticut	L815	1426	1429	S92L0E4500709	S92L0E4500712	4
Démo US	L724	7300	7301	S92Y1D4500275	S92Y3D4500276	2
Duke University - North Carolina	L651	—	—	S92Y1B4000145	S92Y3B4000146	2
Duke University - North Carolina	LA39	—	—	S92LXH9775995	S92LXH9775995	1
LYNX - Florida	L725	—	—	S92Y9D4500329	S92Y5D4500330	2
LYNX - Florida	L764	—	—	S92Y7D4500331	S92Y9D4500332	2
LYNX - Florida	L785	—	—	S92L6E4500505	S92L8E4500506	2
MTD - Santa Barbara, California	L730	—	—	S92J8E4500567	S92J1E4500569	3
New York City Transit - New York	L536	1200	1201	S92U793000490	S92U993000491	2
New York City Transit - New York	L545	1202	1289	S92U5A4000001	S92U0A4000098	88
Saskatoon - Saskatchewan	L551	1005	1007	S92UXA3000178	S92U8A3000180	3
SEPTA - Pennsylvania	L741	7355	7355	S92L4E4500504	S92L4E4500504	1
SEPTA - Pennsylvania	L742	7371	7414	S92L6E4500729	S92L7E4500772	44
SEPTA - Pennsylvania	L743	7356	7370	S92L1E4500489	S92L2E4500503	15
SEPTA - Pennsylvania	L745	7415	7415	S92L0F4500873	S92L0F4500873	1
SEPTA - Pennsylvania	L746	7416	7454	S92L7F4500952	S92L8F4501012	39
SEPTA - Pennsylvania	L749	7302	7354	S92Y7D4500409	S92L2E4500470	53
SEPTA - Pennsylvania	L861	7300	7484	S92L5G9775188	S92L8G9775220	32
St. John - New Brunswick	L272	—	—	S92U483000011	S92U483000011	1
St. John - New Brunswick	L273	—	—	S92U383000050	S92U383000050	1
University of Colorado - Colorado	L627	—	—	S92UXB4000139	S92U6B4000140	2
Walt Disney World - Florida	L763	—	—	S92U0D3001019	S92U4D3001024	6

**WARNING**

Follow your internal safety procedures.

PROCEDURE

- 1.1. Park the vehicle on an even surface with transmission in neutral (N).
- 1.2. Set the Master control switch in the STOP position (see Figure 1).

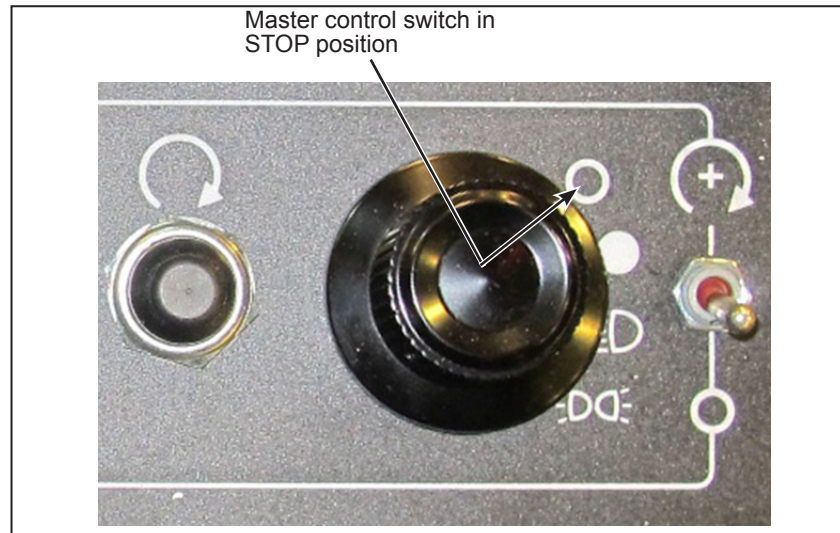

Figure 1 - Master Control Switch in STOP Position

- 1.3. Locate the articulation area inside the vehicle (see Figure 2).



Figure 2 - Typical View of Articulation System Inside the Vehicle

- 1.4. Remove the existing stanchion fixed to the center hoop of the articulation. Discard the stanchion, bolts and washers (see Figure 3).

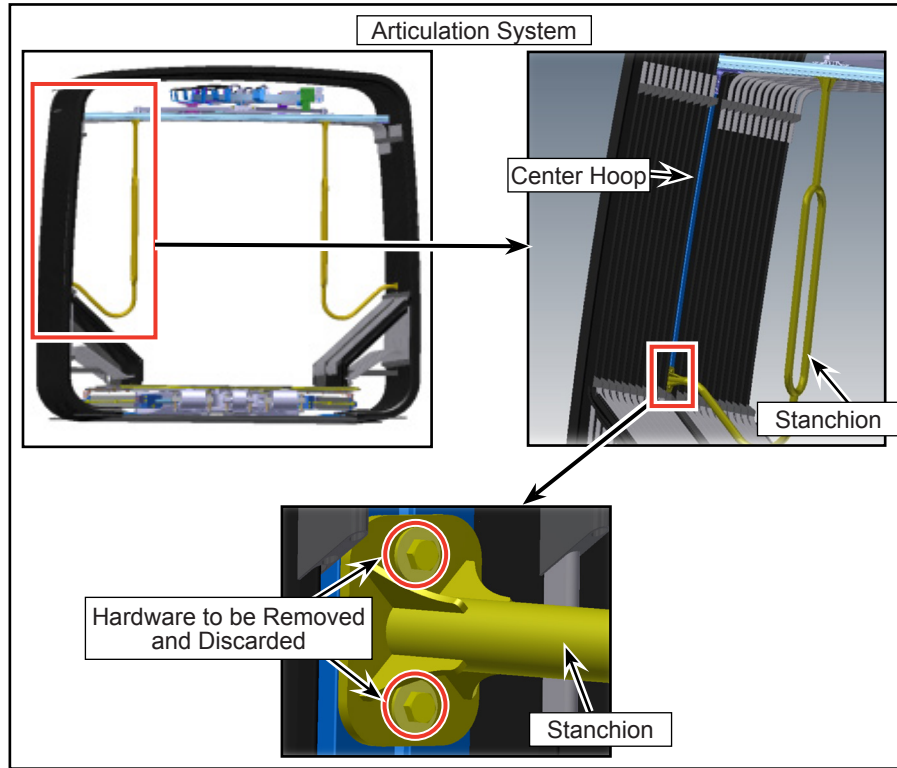

Figure 3 - Removal of Stanchion

- 1.5. Retain the tenon blocks at the same location (inside the center hoop aluminium profile) as shown (see Figure 4).

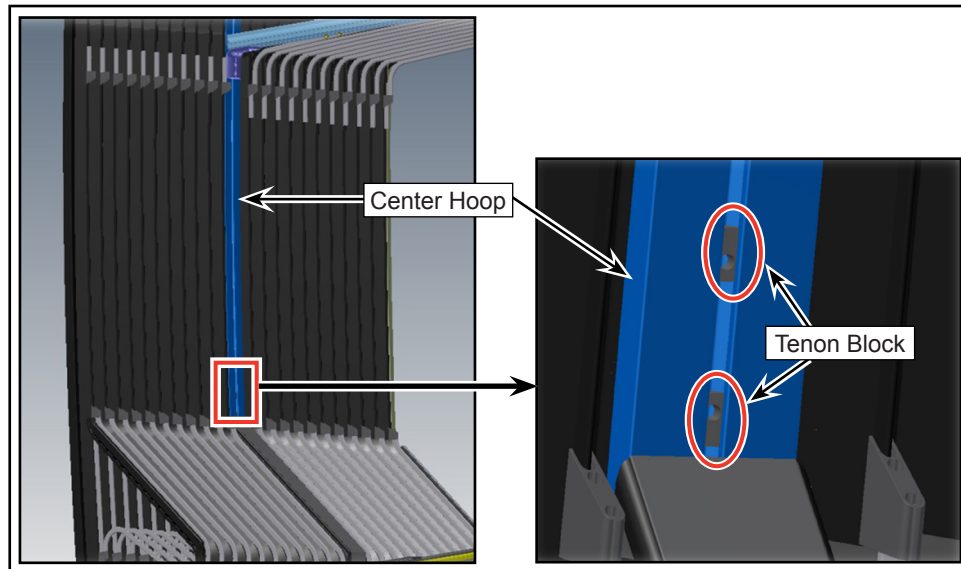

Figure 4 - Typical View of Tenon Block

- 1.6. Install the new tenon block into the center hoop profile (right below the horizontal guiding profile) with a flat screw driver as shown (see Figure 5).

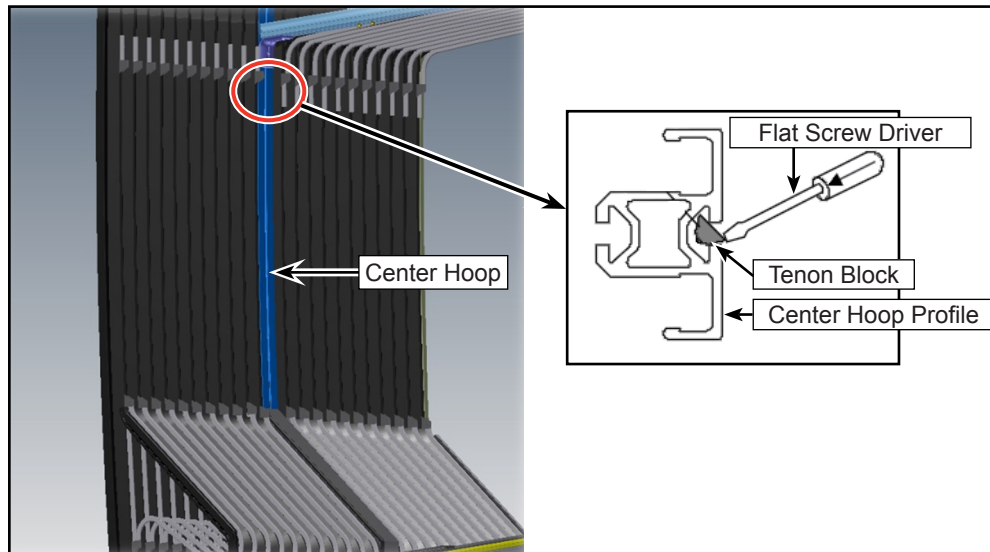

Figure 5 - Installation of Tenon Block

- 1.7. Install the new stanchion on to the tenon block present inside the center hoop profile with the hardware provided (see Figure 6).
- 1.8. Ensure that enough gap (Min. 25 mm) is left between the lower edge of the stanchion and the floor cover profile as shown (see Figure 6).
- 1.9. Apply blue thread locker and torque the bolts as specified (see Figure 6).

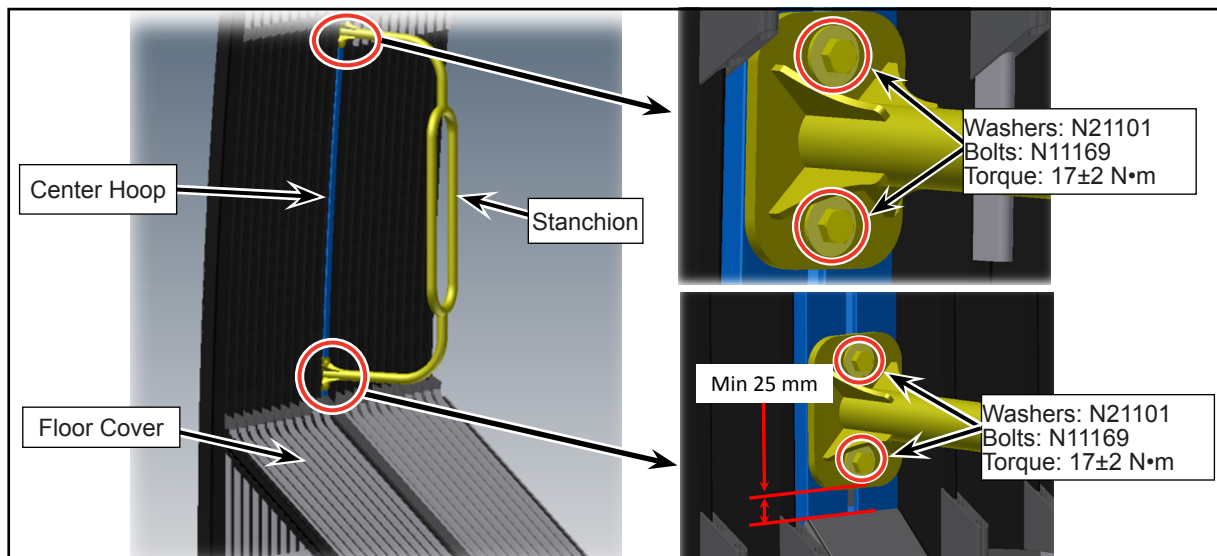

Figure 6 - Installation of New Stanchion

- 1.10. Ensure that the stanchion is vertical (perpendicular to the floor) (see Figure 7).

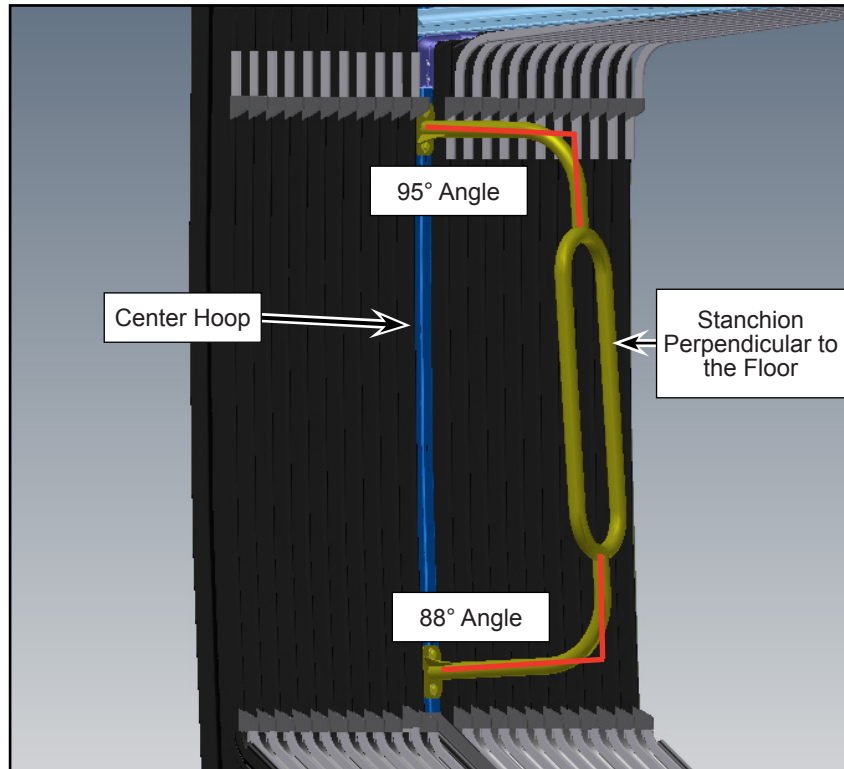

Figure 7 - Typical View of Stanchion Orientation

- 1.11. Apply torque seal on the bolts.
1.12. Set the Master control switch in the ON position.
1.13. The vehicle may be returned to service.