

H114 UPS4118-1bNAS1

TECHNICAL BULLETIN

15 MAY 2018



© Jaguar Land Rover North America, LLC

NOTE: The information in Technical Bulletins is intended for use by trained, professional Technicians with the knowledge, tools, and equipment required to do the job properly and safely. It informs these Technicians of conditions that may occur on some vehicles, or provides information that could assist in proper vehicle service. The procedures should not be performed by 'do-it-yourselfers'. If you are not a Retailer, do not assume that a condition described affects your vehicle. Contact an authorized Jaguar service facility to determine whether this bulletin applies to a specific vehicle.

INFORMATION**SECTION:**

418-02: Wiring Harnesses

SUBJECT/CONCERN:

Update Prior to Sale: Unsealed Splices on Rear Axle and Cabin Harness

AFFECTED VEHICLE RANGE:

MODEL:	MODEL YEAR:	VIN:	ASSEMBLY PLANT:
E-PACE (X540)	2018	Z08161-Z19563	Graz (Austria)

MARKETS:

NORTH AMERICA

CONDITION SUMMARY:**SITUATION:**

An issue has been identified on certain vehicles within the listed Affected Vehicle Range which may have unsealed splices in the wet area on the rear axle and cabin harnesses. Water ingress may lead to numerous failure states across the powertrain and comfort Controller Area Networks (CAN), resulting in Malfunction Indicator Lamps (MIL) and/or warning messages on the Instrument Cluster.

ACTION:

Retailers are required to **HOLD** affected new vehicles that are within your control and refrain from releasing the vehicles for **new vehicle sale** pending completion of the Workshop Procedure detailed in this Technical Bulletin. Unsold vehicles should have this performed as part of the Pre-Delivery Inspection (PDI) process but **must** have it completed prior to vehicle handover to the customer.

This program does not apply to any vehicle already registered and in use, either with the retailer or customer. Any vehicle already in use may continue to be driven and any repair instructions deemed necessary will be communicated through a separate Field Action or Technical Bulletin.

PARTS:**NOTE:**

Order only the expected percentage demand of parts identified.

DESCRIPTION	PART NO./SUNDRY CODE	QTY./VALUE	EXPECTED PERCENTAGE DEMAND
50mm heat shrink (4) Electrical tape 300mm x 4.5mm cable tie (1)	ZZZ999	*\$0.45	100

* - an allowance of \$0.45 USD or local equivalent has been provided to cover the cost of the heat shrink, electrical tape, and cable tie.

SPECIAL TOOLS:

Refer to TOPIx Workshop Manual/Workshop Procedure for any required special tools.

WARRANTY:**NOTE:**

Use the Jaguar Land Rover claims submission system to make sure that a vehicle is affected by this program prior to undertaking any rework action.

At the time of confirming a booking for vehicle repair, make sure that **all** outstanding Recall and Service Actions are identified to ensure the correct parts are available and adequate workshop time is allocated for repairs to be completed at one visit.

Warranty claims must be submitted quoting the Program Code and the relevant Option Code; this will result in payment of the stated time. The SRO and parts information is included for information only. The Option Code(s) that allows for the drive in/drive out allowance may only be claimed if the vehicle is brought back into the workshop for this action alone to be undertaken.

Repair procedures are under constant review and therefore times / prices are subject to change; those quoted here must be taken as guidance only. Use the Jaguar Land Rover claims submission system to obtain the latest repair time.

This program is valid for a limited time only. Warranty claims with a repair date prior to the **1 May 2019** closure date must be submitted or payment within 30 calendar days of completion of the repair.

PROGRAM CODE	OPTION CODE	DESCRIPTION	SRO	TIME (HOURS)	PARTS/SUNDRY CODE	QTY./VALUE
H114	A	Wiring harness rework	86.71.42	0.5	ZZZ999	*\$0.45
H114	B	Wiring harness rework Drive in/drive out	86.71.42 10.10.10	0.5 0.2	ZZZ999 -	*\$0.45 -

* - an allowance of \$0.45 USD or local equivalent has been provided to cover the cost of the heat shrink, electrical tape, and cable tie.

Normal Warranty policies and procedures apply.

WORKSHOP PROCEDURE:

NOTES:

- Some variation in the illustrations may occur, but the essential information is always correct.
- Some components shown removed for clarity.

- 1 Remove the rear left wheel arch liner (see TOPIx Workshop Manual section 501-08: Exterior Trim and Ornamentation - Rear Wheel Arch Liner).

2

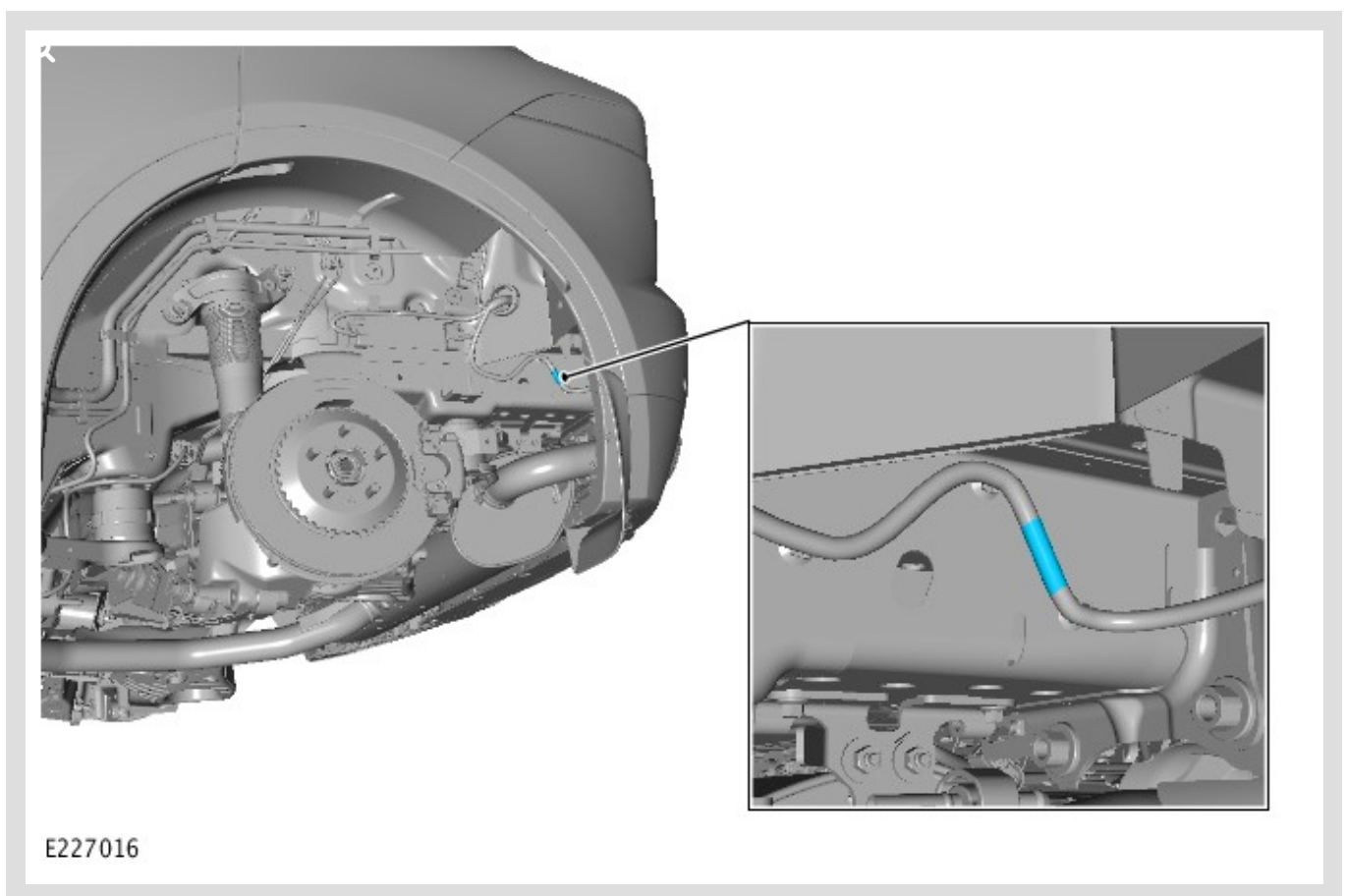

Unwrap the body wiring harness protection and access the body wiring harness located in the area shown.

- 3 Locate splices **S3DB27G** and **S3DB28G** using (see TOPIx section Electrical Information - Electrical Wiring Diagrams - 413-09: Warning Devices - Blind spot monitoring system).

4

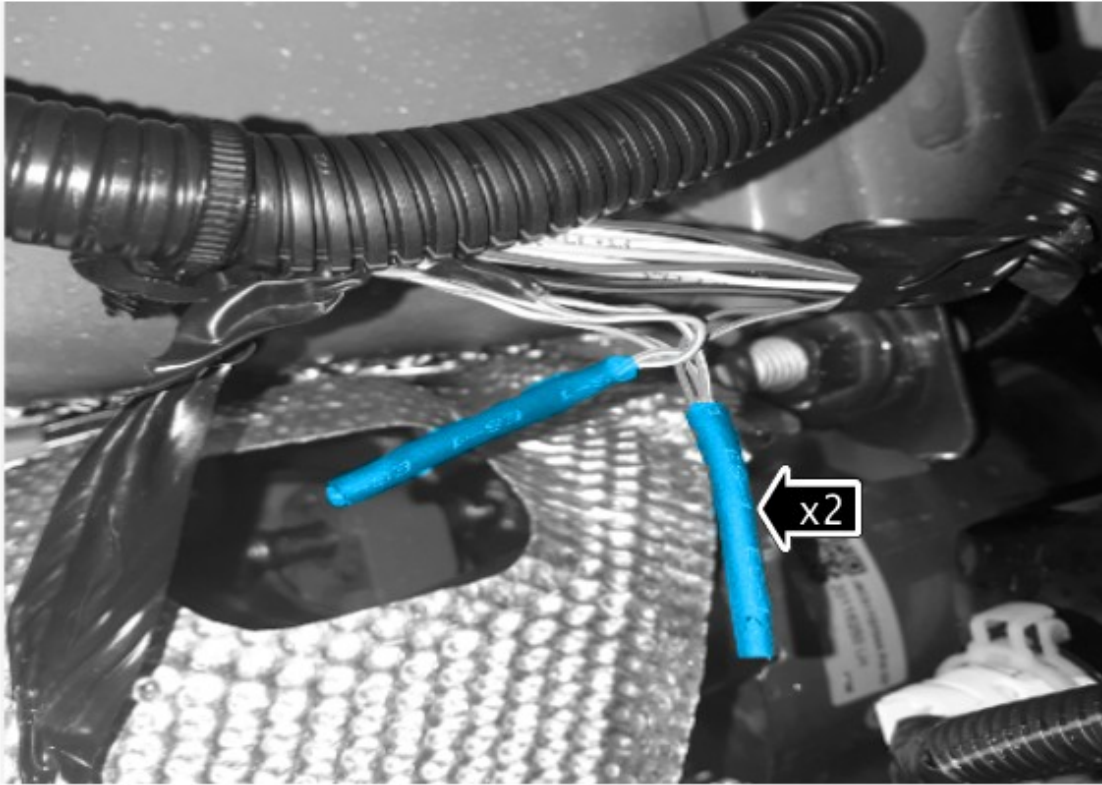

E227017

Apply heat shrink to splices **S3DB27G** and **S3DB28G**

- 1 Apply electrical tape.
- 2 Install the body wiring harness protection.

- 5 Install the rear left wheel arch liner (see TOPIx Workshop Manual section 501-08: Exterior Trim and Ornamentation - Rear Wheel Arch Liner).

- 1 Do not lower the vehicle.

6

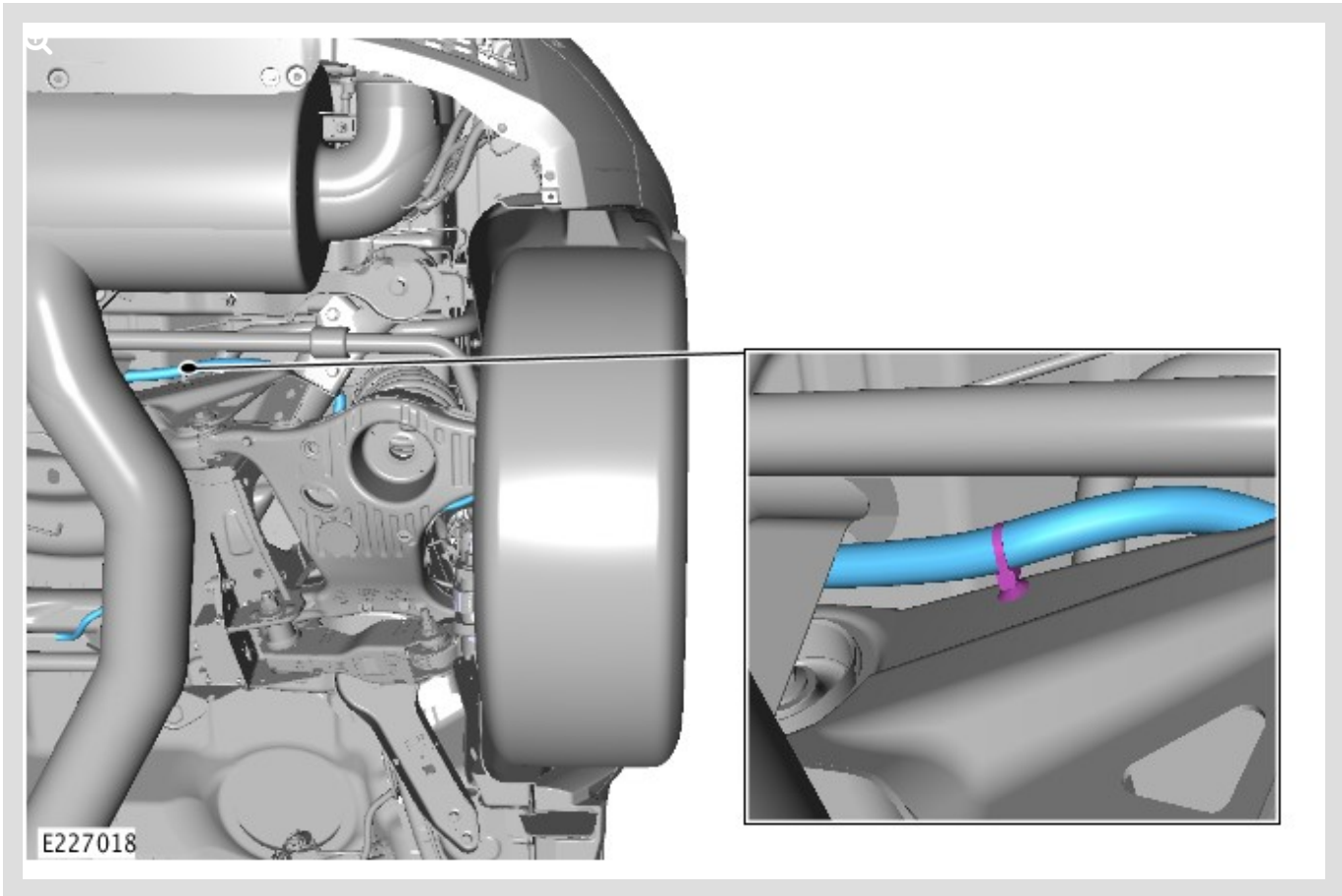

Locate the rear axle wiring harness.

7

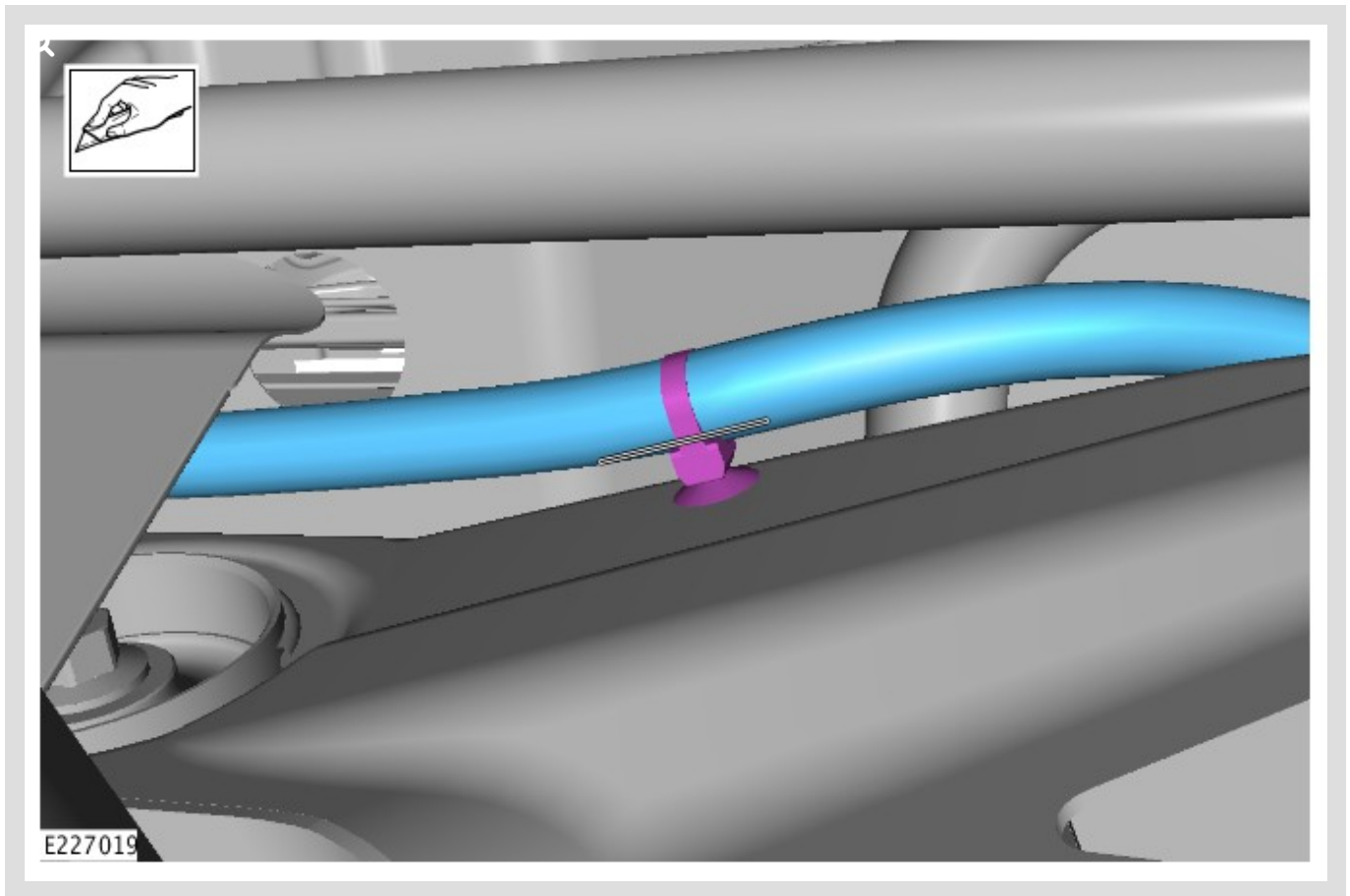

Access the rear axle wiring harness.

- 1 Cut the cable tie.
- 2 Remove the axle wiring harness protection.

8 Locate splices **S4DB26GD**, **S4DB25GD**, **S4DB26GE**, and **S4DB25GE** (see TOPIx section Electrical Information - Electrical Wiring Diagrams - 205-02: Rear Drive Axle and Differential:).

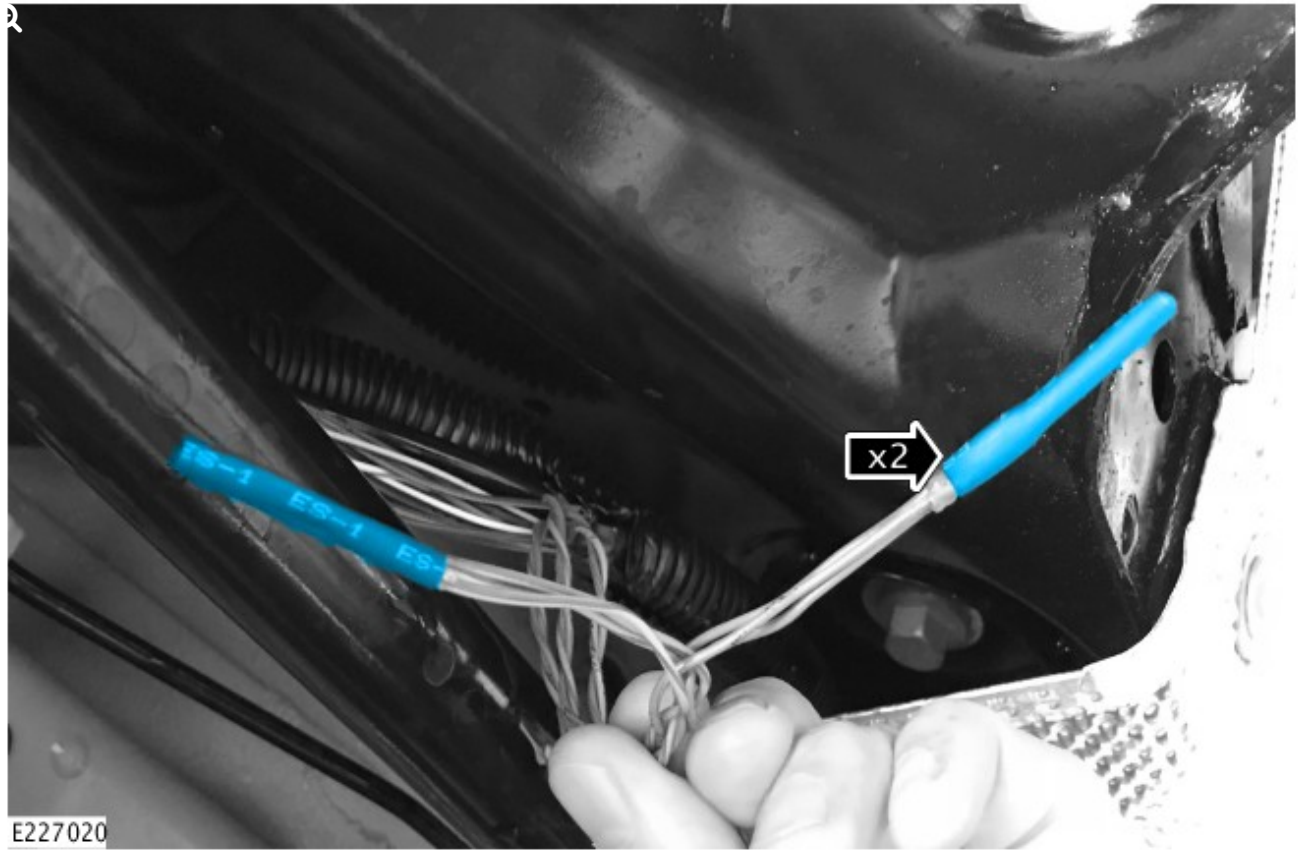

Apply heat shrink to splices as shown:

- 1 S4DB26GD and S4DB25GD**
- 2 S4DB26GE and S4DB25GE**
- 3** Apply electrical tape.
- 4** Install the body wiring harness protection.

10

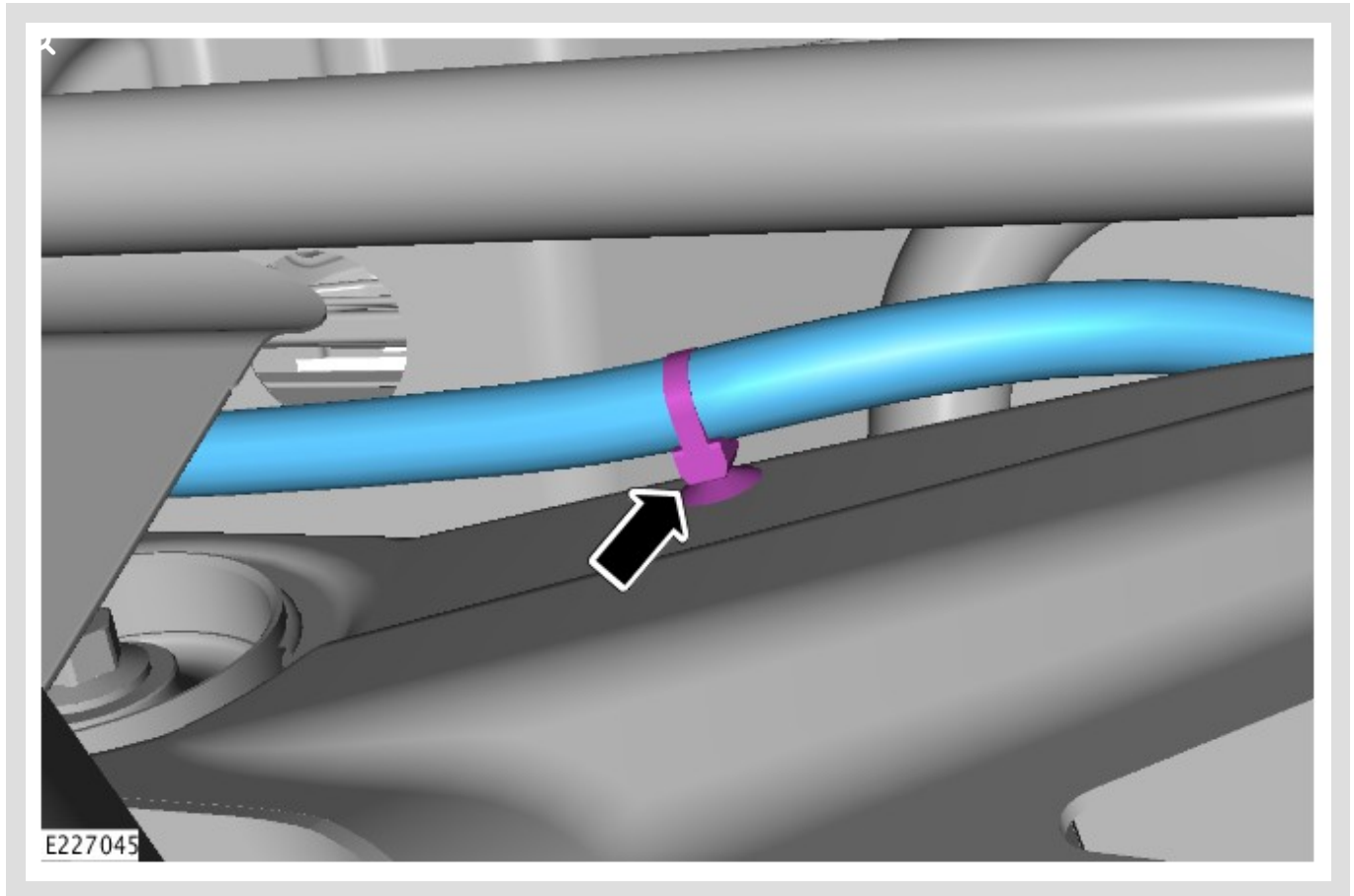

Install the rear axle wiring harness.

- 1 Use a new cable tie to the base of the original fastener.

11 Lower and release the vehicle.