

H037NAS4

TECHNICAL BULLETIN

10 MAY 2018



© Jaguar Land Rover North America, LLC

NOTE: The information in Technical Bulletins is intended for use by trained, professional Technicians with the knowledge, tools, and equipment required to do the job properly and safely. It informs these Technicians of conditions that may occur on some vehicles, or provides information that could assist in proper vehicle service. The procedures should not be performed by 'do-it-yourselfers'. If you are not a Retailer, do not assume that a condition described affects your vehicle. Contact an authorized Jaguar service facility to determine whether this bulletin applies to a specific vehicle.

INFORMATION

Changes are highlighted in blue

SECTION:

211-03: Steering Linkage

SUBJECT/CONCERN:

Service Action: Steering Gear Tie-Rod End Ball Joints

AFFECTED VEHICLE RANGE:

MODEL:	MODEL YEAR:	VIN:	ASSEMBLY PLANT:
F-PACE (X761)	2017-2018	045119-099996	Solihull
F-PACE (X761)	2017	488002-499998	Solihull

MODEL:	MODEL YEAR:	VIN:	ASSEMBLY PLANT:
F-PACE (X761)	2017-2018	880002-899840	Solihull
F-PACE (X761)	2018	240000-257978	Solihull

MARKETS:

NORTH AMERICA

CONDITION SUMMARY:

SITUATION:

An issue has been identified on certain vehicles within the listed Affected Vehicle Range where the steering gear tie-rod end ball joints have not been suitably sealed from exterior weather conditions. Water or other contaminants may be able to enter the steering gear tie-rod end ball joints which could lead to the ball joint developing a knocking noise after long exposure.

ACTION:

Retailers are required to **HOLD** affected new vehicles that are within your control and refrain from releasing the vehicles for **new vehicle sale** pending completion of the Workshop Procedure detailed in this Technical Bulletin. Unsold vehicles should have this performed as part of the Pre-Delivery Inspection (PDI) process but **must** have it completed prior to vehicle handover to the customer.

Affected vehicles already in the hands of customers should be updated at the next available opportunity.

PARTS:

DESCRIPTION	PART NO./SUNDRY CODE	QTY./VALUE
‡ Daubert NOX-RUST® 7703-W (aerosol spray can*)	Locally sourced	1 can*
‡ Teroson WX 350 / Terotex HV 350 - 1 liter	T4A30297	1*
Windshield bonding felt swab applicator	**ZZZ001	**\$0.10

‡ - Daubert 'NOX-RUST® 7703-W **OR** Teroson WX 350 / Terotex HV 350 may be used.

* - sufficient to rework 50 vehicles.

** - an allowance of \$0.10 USD or local equivalent has been provided to cover the cost of 1 windshield bonding felt swab applicator.

SPECIAL TOOLS:

Refer to TOPIx Workshop Manual/Workshop Procedure for any required special tools.

WARRANTY:

NOTE:

Use the Jaguar Land Rover claims submission system to make sure that a vehicle is affected by this program prior to undertaking any rework action.

At the time of confirming a booking for vehicle repair, ensure that **all** outstanding Recall and Service Actions are identified to ensure the correct parts are available and adequate workshop time is allocated for repairs to be completed at one visit.

Warranty claims must be submitted quoting the Program Code together with the relevant Option Code. The SRO and parts information is included for information only. The Option Code(s) that allows for the drive in/drive out allowance can only be claimed if the vehicle is brought back into the workshop for this action alone to be undertaken.

Repair procedures are under constant review and therefore times / prices are subject to change; those quoted here must be taken as guidance only. Use the Jaguar Land Rover claims submission system to obtain the latest repair time.

This program is valid for a limited time only. Warranty claims with a repair date prior to the **31 August 2019** closure date must be submitted or payment within 30 calendar days of completion of the repair.

PROGRAM CODE	OPTION CODE	DESCRIPTION	SRO	TIME (HOURS)	PARTS/SUNDRY CODE	QTY./VALUE
--------------	-------------	-------------	-----	--------------	-------------------	------------

PROGRAM CODE	OPTION CODE	DESCRIPTION	SRO	TIME (HOURS)	PARTS/SUNDRY CODE	QTY./VALUE
H037	A	Inspect the tie-rod bellow clamp for a yellow paint mark, indicating that the repair has previously been completed, no further action	05.10.20	0.20	-	-
H037	K	Inspect the tie-rod bellow clamp for a yellow paint mark, indicating that the repair has previously been completed, no further action Drive in/drive out	05.10.20 10.10.10	0.20 0.20	- -	- -
H037	F	Seal the steering gear tie-rod end ball joints	57.91.41	0.30	ZZZ001	*\$0.60
H037	G	Seal the steering gear tie-rod end ball joints Drive in/drive out	57.91.41 10.10.10	0.30 0.20	ZZZ001 -	*\$0.60 -

*- an allowance of \$0.60 USD or local equivalent has been provided to cover the cost of 1 windshield bonding felt swab applicator and the wax.

Normal Warranty policies and procedures apply.

WORKSHOP PROCEDURE:

1 Raise and support the vehicle (see TOPIX Workshop Manual section 100-02: Jacking and Lifting).

2  **NOTE:**

Right tie-rod shown; left tie-rod similar.

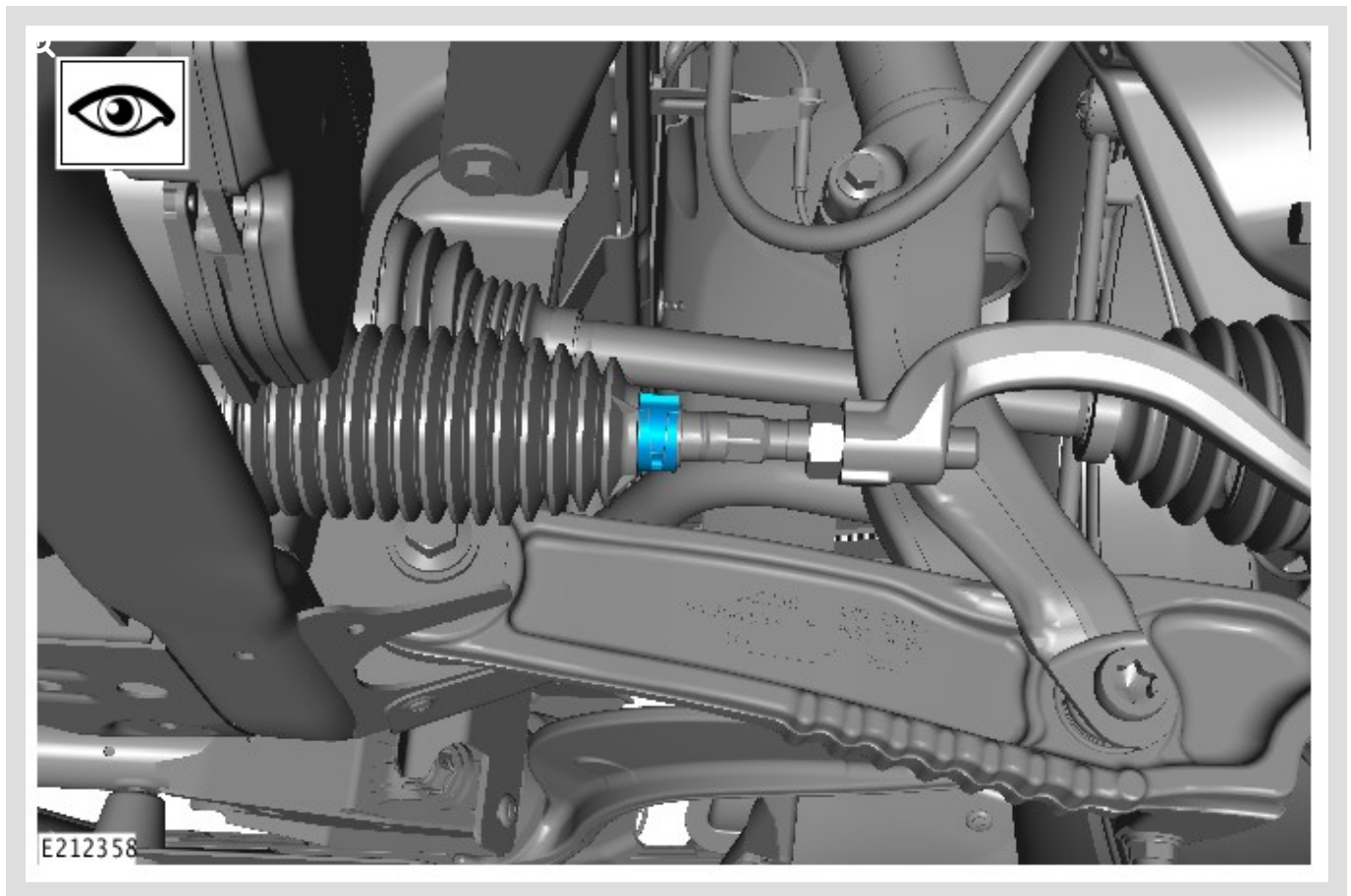

Inspect the tie-rod bellow clamp for a yellow paint mark indicating that the repair has previously been completed.

- If the identification mark is present, **go to Step 6.**
- If the identification mark is not present, **go to Step 3.**

3

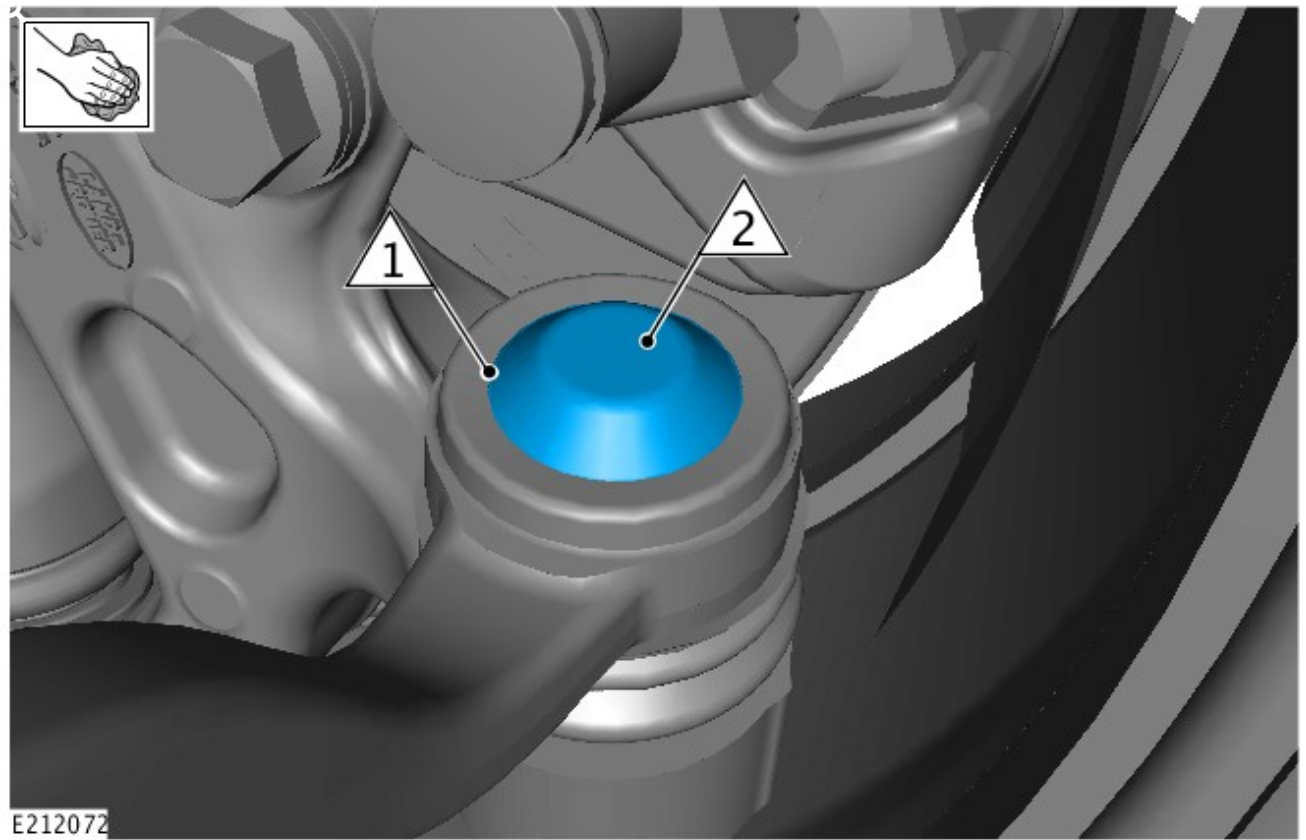

Clean rust and visible contaminants from the area shown in the illustration.

- 1 Use a scribe to clean the area between the retaining cap joint.
- 2 Use a suitable tool to clean the retaining cap surface.

4

NOTE:

The area must be dry before application of the sealing wax.

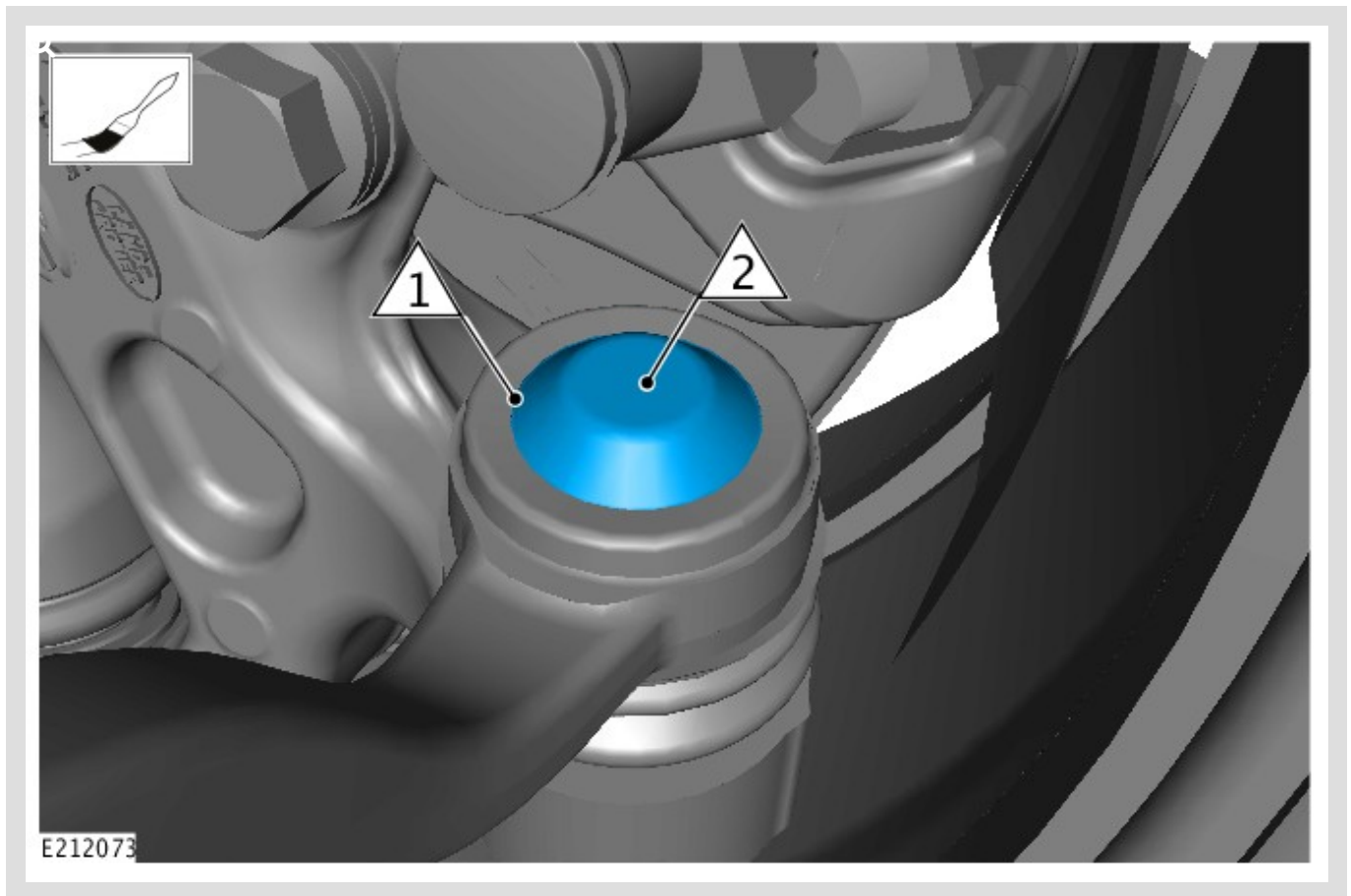

Apply the sealing wax to the tie-rod end retaining cap.

- 1 Make sure there is sufficient wax applied to seal the retaining joint cap.
- 2 Make sure the wax coats all of the retaining cap surface.

5

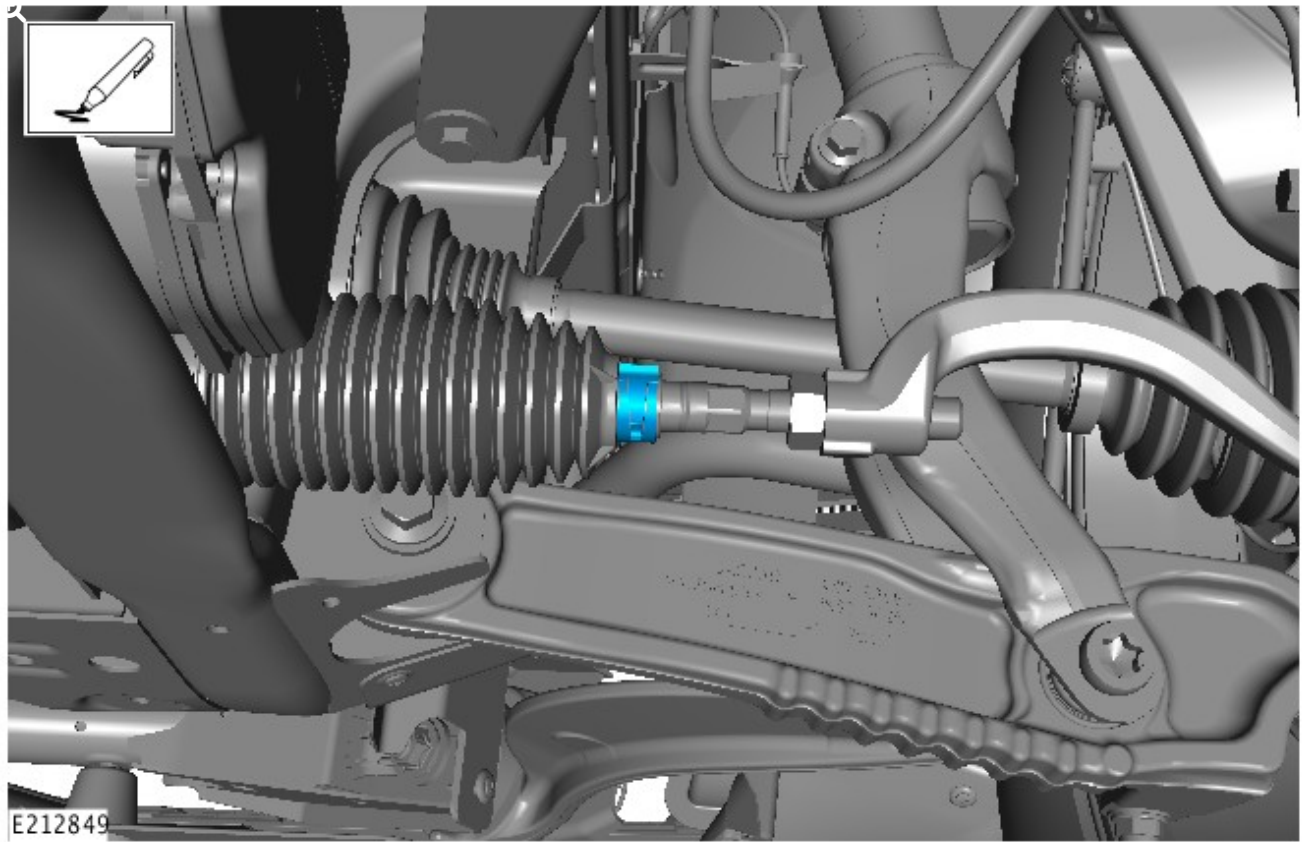

Apply yellow paint mark to the tie-rod bellow clamp to indicate completion of the repair.

6 Perform Steps 2-5 to the left tie-rod.

7 Lower the vehicle (see TOPIX Workshop Manual section 100-02: Jacking and Lifting).

8 Release the vehicle.

- If a repair has been carried out, the vehicle should not be washed for at least 4 hours to allow the wax time to dry.