

FLA COE
FLB COE
FLD Conventional
Business Class
FLC 112 Conventional

Century Class Conventional
Argosy COE
Cargo
Columbia

> 122SD and Coronado
> Business Class M2
> Cascadia
> 108SD/114SD

**Freightliner
Service Bulletin**

General Information

In June 2016, a design change removed the magnets from the fill necks for some 6 gallon DEF tanks. Due to some customer's needs for a magnetized filler neck, a fill neck with an incorporated magnet (04-32529-001) is now offered, and can be retrofitted. See [Fig. 1](#).

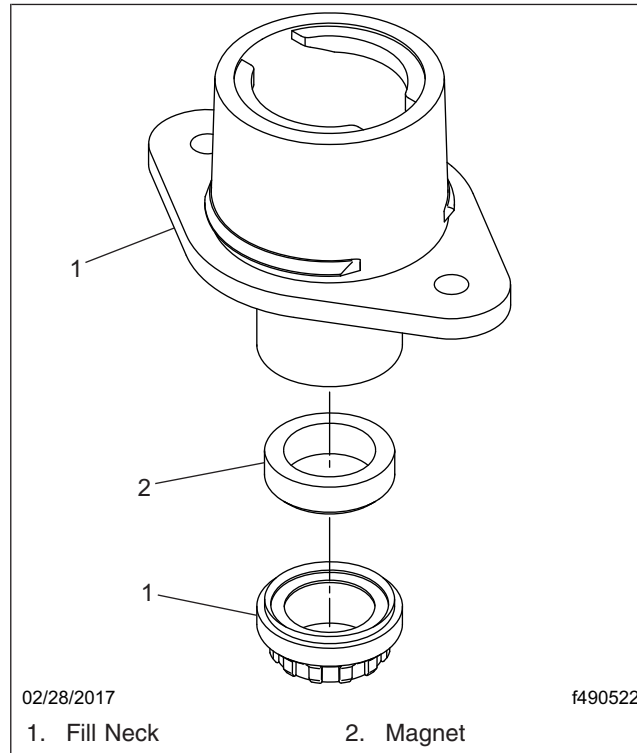

Fig. 1, Magnetized Fill Neck

Fill Neck Replacement

Refer to [Fig. 2](#) for this procedure.

Freightliner Service Bulletin

FLA COE
FLB COE
FLD Conventional
Business Class
FLC 112 Conventional

Century Class Conventional
Argosy COE
Cargo
Columbia

> 122SD and Coronado
> Business Class M2
> Cascadia
> 108SD/114SD

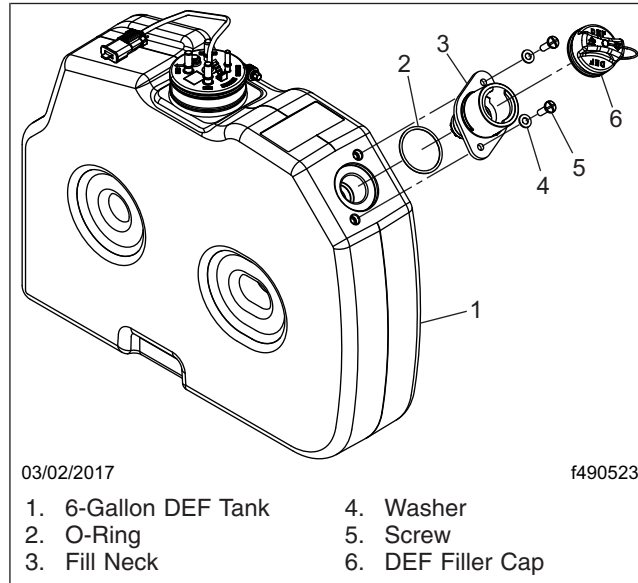

Fig. 2, Filler Neck Installation

1. Park the vehicle on a level surface, shut down the engine, and set the parking brake. Chock the tires.
2. Remove the screws and washers.
3. Lift off the old filler neck, and discard.
4. Install the O-ring on the new filler neck.
5. Position the new filler neck (with the incorporated magnet) on the DEF tank.

NOTICE

The tank has captured nuts incorporated for attaching the filler neck. Over tightening the fasteners may damage the tank and require replacing it.

6. Install the screws and washers. Tighten the screws 48 lbf·in (540 N·cm). Do not over tighten.

Parts

Parts are available through the PDC.

Warranty

This bulletin is informational only. Warranty does not apply.